

ION BLASTER BEAM™ - Quiet, Super Efficient, Concentrated flow of ionized air to eliminate static charge and remove dust!



ION BLASTER BEAM™ APPLICATIONS

- Eliminate static charge and cleaning parts
- Neutralize shrink wrap
- Form fill and seal applications for bag opening
- Neutralizing and cleaning the inside of blow molded parts
- Eliminate static and cleaning of plastic assemblies
- Dust removal from parts prior to painting
- Remove static charge in slitting applications
- Cleaning of packaging
- Neutralization of static charge inside containers

WHAT ARE THEY - REASONS TO USE

The *Nex Flow™ Ion Blaster Beam™* neutralizes static electricity and can remove static free dust up to 15 feet (4.6 m) away with no moving parts. It's compact design allows it to be used in hard to reach areas or confined spaces. The air volume and velocity are infinitely adjustable over a wide range using a pressure regulator to address any application from light to heavy duty. The use of an "air amplifier" (Model AM40) maximizes ionized airflow with large volume entrained while minimizing the use of compressed air. (See Air Amplifiers elsewhere in the catalog). In most applications only 10 psig (0.7 bar) is required to operate effectively. The Ionizing Point is a powerful ionizer which remains effective because the air exit "plastic PET head" of the unit prevents weakening of ions which metal attachments may do. This can make the *Ion Blaster Beam™* far more effective than systems using metal

ION BLASTER BEAM™ FEATURES

- Effective Static Elimination
- Can clean static free dust at a distance
- Compact Design to fit in small spaces
- Stand is pre-drilled for easy mounting

ION BLASTER BEAM™ BENEFITS

- Low compressed air use
- Rapid static decay
- Quiet Operation
- Shockless and non-radioactive
- Compact and rugged design
- Intake may be ducted to bring in atmospheric air from another area
- no moving parts and minimal maintenance
- Variable flow and force

DIMENSIONS

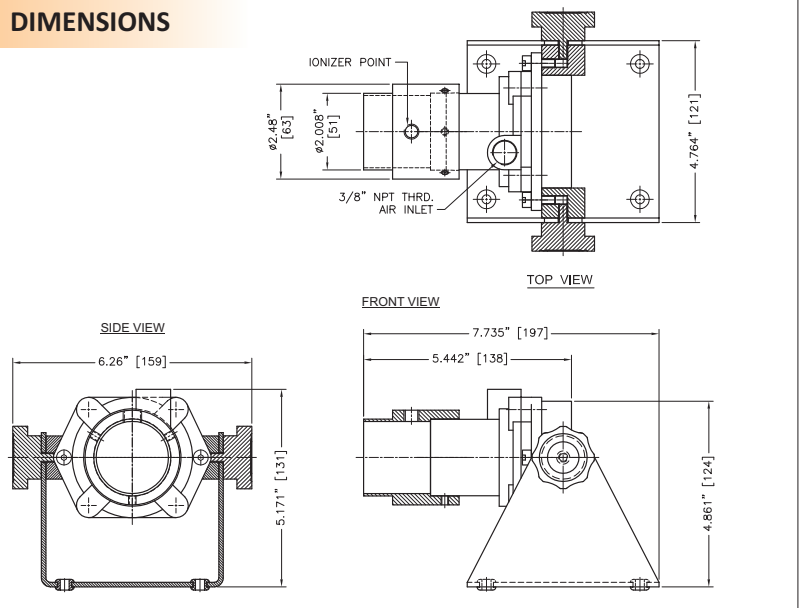

STATIC ELIMINATORS

HOW IT WORKS

To be completed

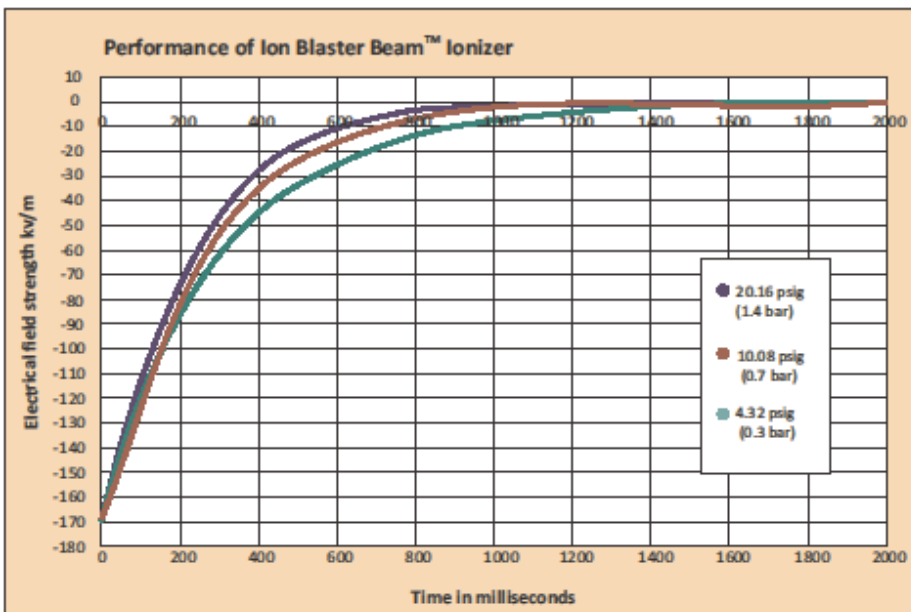

PART NO.	DESCRIPTION
17040	Ion Blaster Beam™ includes Air Amplifier, Spot Ionizer. Stand and 2 Meters shielded cable.
17140	Ion Blaster Beam™ and Power Supply
17340	Ion Blaster Beam™ Kit (c/w Ion Blaster Beam™, Power Supply, Model 90001 water removal filter and Model 90008 regulator wi. gage
80111	120 V Power Supply, 2 outlet
80121	230V Power Supply, 2 outlet
80112	120 V Power Supply, 4 outlet
80122	230 V Power Supply, 4 outlet
90001	Water Removal Filter c/w auto Drain
90008	Water Removal Filter c/w auto Drain

ION AIR BLASTER BEAM™ SPECIFICATIONS

Certification: North American Power Supplies certified to UL and CSA standards and Spot Ionizer used with the Ion Blaster beam is included with the certification. European Power Supplies CE approved and Spot Ionizer used with the Ion Blaster Beam is included with the certification. Stainless steel emitters on the ionizer.

Electrical: For use with 7 kV rms, 5 milliamperes (max) power supply which will last much longer than 5 kv power supplies.

Electrical Hazard: Shockless (less or eualt to 5mA)

Maximum Ambient Temperature: 122 degrees F or 50 degrees C.

