

1/4" NPT  
AIR INLET

Ø2.2" [Ø57.1]

M6 X 3 HOLES ON  
Ø1.8" [Ø45.1]  
PCD

Ø0.7" [Ø19.0]  
THRU THROAT DIAMETER

VACUUM

1" NPT (M)  
BOTH SIDES

**PROPRIETARY**  
REPRODUCTION OR DISTRIBUTION  
WITHOUT WRITTEN CONSENT OF  
NEXFLOW™ IS PROHIBITED.

THIRD ANGLE PROJECTION		REQUIREMENTS—UNLESS OTHERWISE SPECIFIED		CONTRACT NUMBER		NEX FLOW AIR PRODUCTS CORP. 10520 YONCE STREET, UNIT 350-220, RICHMOND HILL, ON L4G 3G7 TEL: (416) 410-1313 & FAX: (416) 410-1806 www.nfx-flow.com	
MATERIAL		GENERAL		CLIENT		TITLE	
HIGH TEMPERATURE STAINLESS STEEL		1. DIMS ARE IN INCHES (MM)		CONTRACTOR		1" THREADED HIGH TEMPERATURE STAINLESS STEEL RING VAC	
FINISH		2. DIMENSIONING AND TOLERANCING IN ACCORDANCE WITH ANSI Y14.5 (1982)		DATE		SIZE	
BUFFING		3. MACHINE FINISH 125 MICRO INCH RMS		25/04/2021		C	
NEXT ASSEMBLY		4. INTERNAL RADIUS .015" (0.4)		CHECKED		DWG NO	
USED ON		5. BREAK SHARP CORNERS 0.005" (0.1) TO 0.015" (0.4)		LES		30001THTS	
CITY FOR PART NO		LIMITS		PROJECT		RELEASE	
PART NO		1. LINEAR DIMS: XX = .005" (0.1) YY = .010" (0.2) ZZ = .020" (0.5)		Q/A		P	
		2. ANGLES = ± 1/2°		STRESS		REV	
		3. ROUNDOFF .010 DIA		MANUFACTURING		-	
		4. HOLES IN ACCORDANCE WITH AND 10387		THERMAL		-	
				MATERIALS		-	
				MECHANISM		-	
				ELECTRICAL		-	
				SCALE		1:1	
				Dwg No		-	
				Sheet		1 of 1	

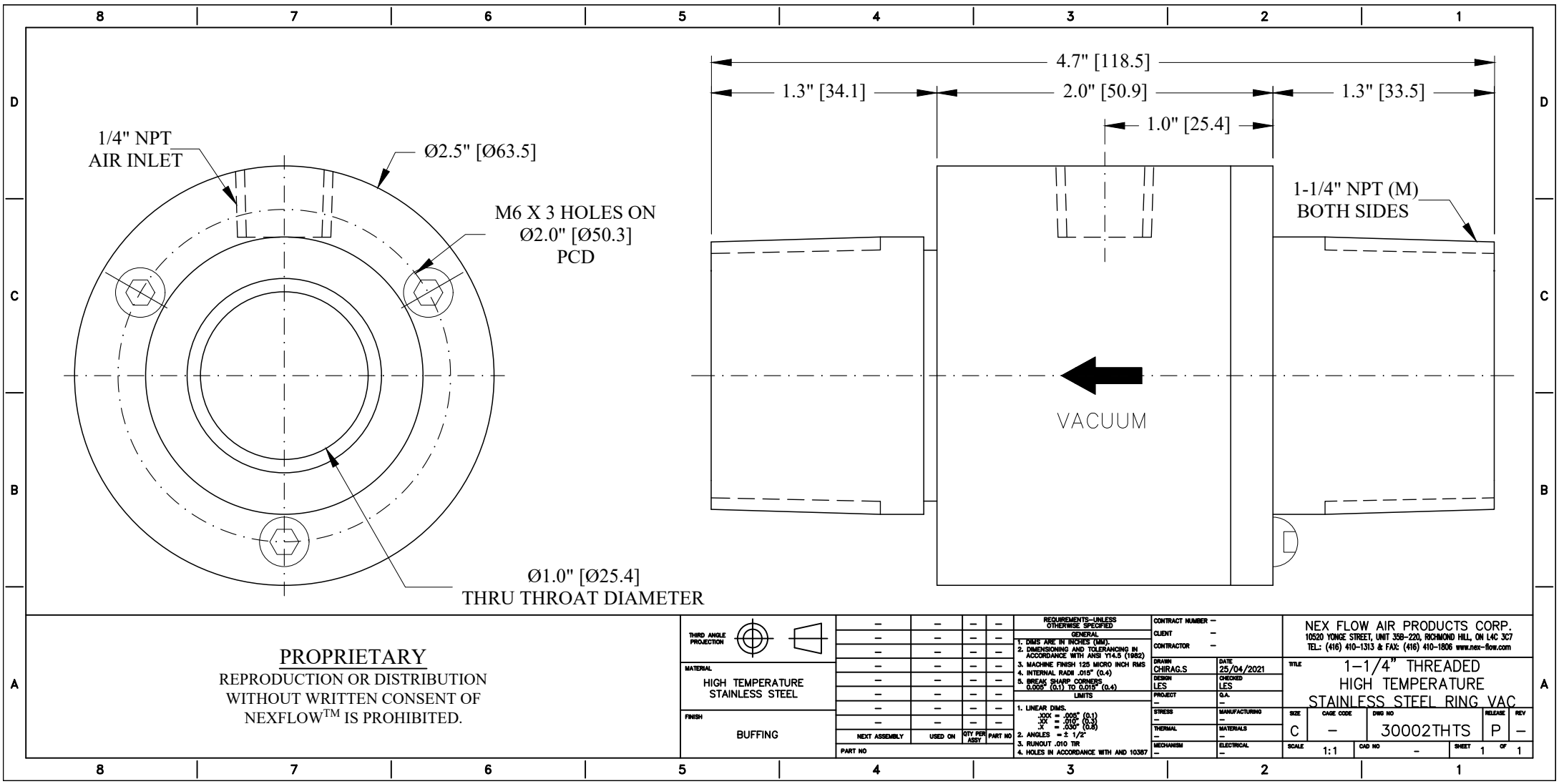

**PROPRIETARY**  
 REPRODUCTION OR DISTRIBUTION  
 WITHOUT WRITTEN CONSENT OF  
 NEXFLOW™ IS PROHIBITED.

THIRD ANGLE PROJECTION		—	—	—	—	REQUIREMENTS—UNLESS OTHERWISE SPECIFIED	CONTRACT NUMBER —	NEX FLOW AIR PRODUCTS CORP. 10520 YONGE STREET, UNIT 35B-220, RICHMOND HILL, ON L4C 3C7 TEL: (416) 410-1313 & FAX: (416) 410-1806 www.nex-flow.com	
		—	—	—	—	GENERAL	CLIENT —	TITLE 1-1/4" THREADED HIGH TEMPERATURE STAINLESS STEEL RING VAC	
MATERIAL	HIGH TEMPERATURE STAINLESS STEEL	—	—	—	—	1. DIMS ARE IN INCHES (DIM.)	CONTRACTOR —	DATE 25/04/2021	SIZE C
		—	—	—	—	2. DIMENSIONING AND TOLERANCING IN ACCORDANCE WITH ANSI Y14.5 (1982)	DESIGN LES	CHECKED	DWG NO 30002THTS
FINISH	BUFFING	—	—	—	—	3. MACHINE FINISH 125 MICRO INCH RMS	PROJECT —	MATERIALS —	SCALE 1:1
		—	—	—	—	4. INTERNAL RADI .015" (0.4)	STRESS —	ELECTRICAL —	CAD NO —
		—	—	—	—	5. BREAKS SHARP CORNERS 0.005" (0.1) TO 0.015" (0.4)	LIMITS	MANUFACTURING —	SHEET 1 OF 1
		—	—	—	—	1. LINEAR DIMS. XX = .005" (0.1) YY = .010" (0.3) ZZ = .030" (0.8)	—	—	REV P
		—	—	—	—	2. ANGLES ≈ ± 1/2°	—	—	—
		—	—	—	—	3. FINISH .010 TIR	—	—	—
		—	—	—	—	4. HOLES IN ACCORDANCE WITH AND 10387	—	—	—
		—	—	—	—		—	—	—

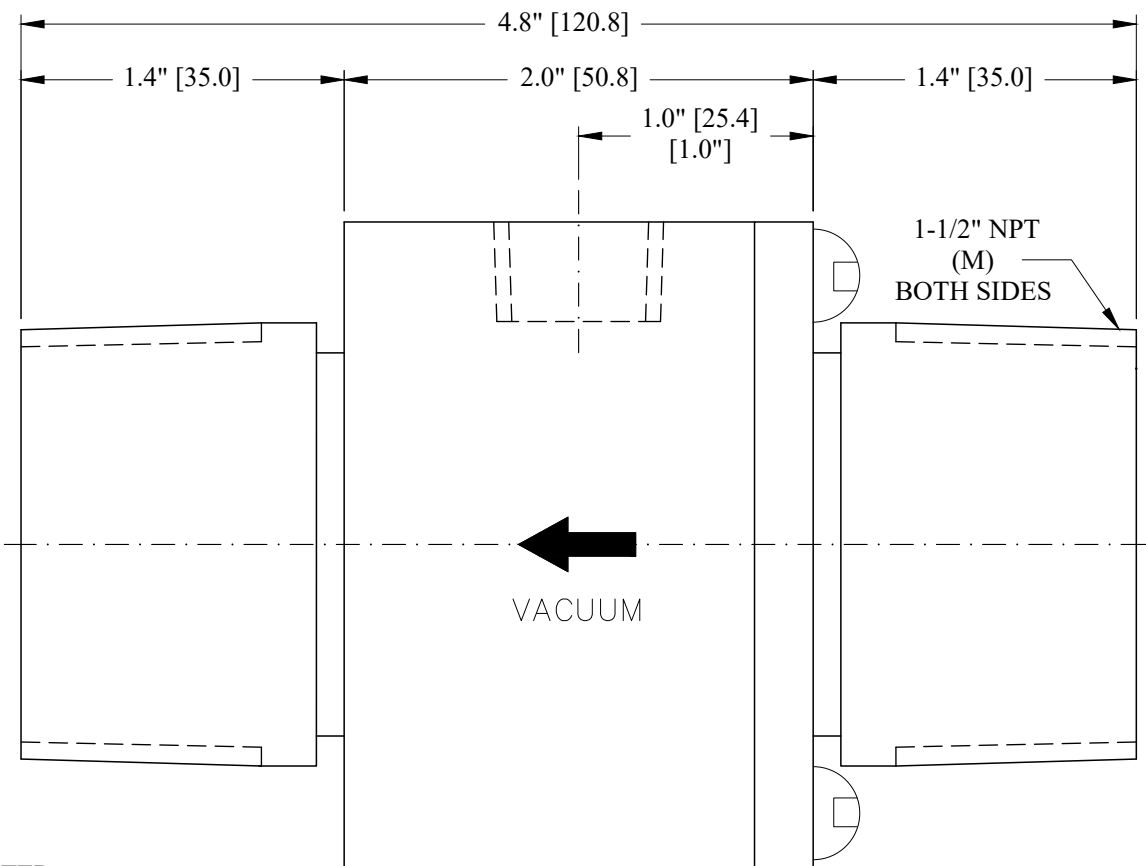
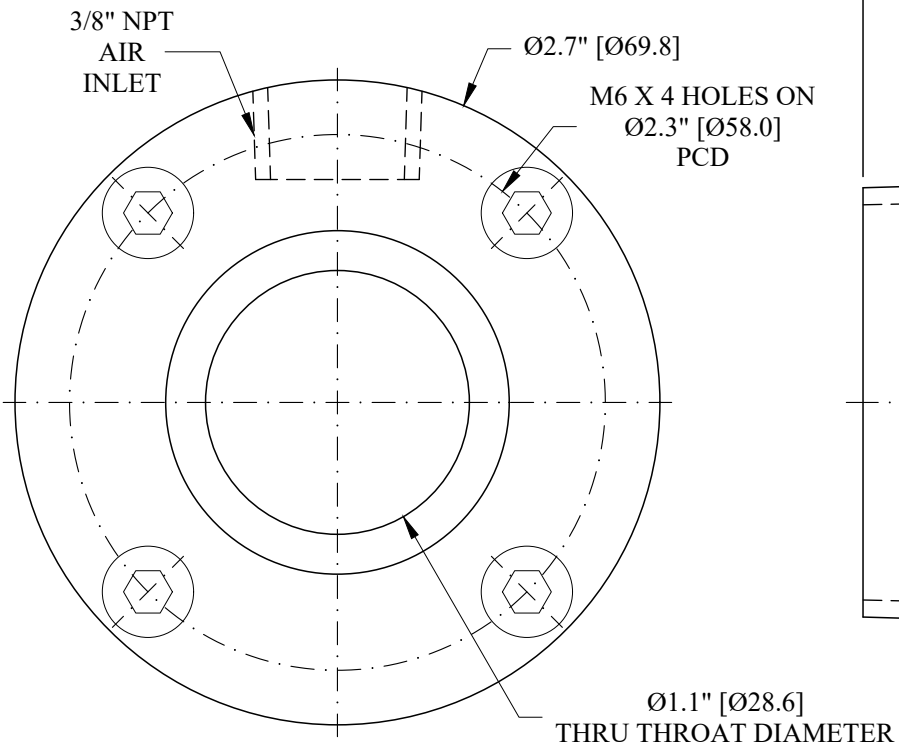

**PROPRIETARY**  
 REPRODUCTION OR DISTRIBUTION  
 WITHOUT WRITTEN CONSENT OF  
 NEXFLOW™ IS PROHIBITED.

THIRD ANGLE PROJECTION		REQUIREMENTS—UNLESS OTHERWISE SPECIFIED	CONTRACT NUMBER	NEX FLOW AIR PRODUCTS CORP. 10520 YONGE STREET, UNIT 35B-220, RICHMOND HILL, ON L4C 3C7 TEL.: (416) 410-1313 & FAX: (416) 410-1006 www.nex-flow.com			
		GENERAL	CLIENT	1-1/2" THREADED HIGH TEMPERATURE STAINLESS STEEL RING VAC			
MATERIAL	HIGH TEMPERATURE STAINLESS STEEL	1. DIMS ARE IN INCHES (IN)	CONTRACTOR	DATE	25/04/2021	DESIGN	CHIRAGS
FINISH	BUFFING	2. DIMENSIONS AND TOLERANCES IN ACCORDANCE WITH ASME Y14.3 (2002)	DESIGN	LESS	LESS	PRODUCT	GA
		3. MACHINE FINISH 125 MICRO INCH RMS	STRESS	MANUFACTURING	SCALE	1:1	1 OF 1
		4. INTERNAL RASH .015" (0.4)	THERMAL	MATERIALS	DATE CODE	30003THTS	REV
		5. BREAK SHARP CORNERS 0.005" (0.1) TO 0.015" (0.4)	MATERIALS	ELECTRICAL	RELEASE	P	REV
		6. ANGLES = 2.1/2"	MECHANISM				
		7. ROUNDOFF .010 TR					
		8. HOLES IN ACCORDANCE WITH AND 10367					

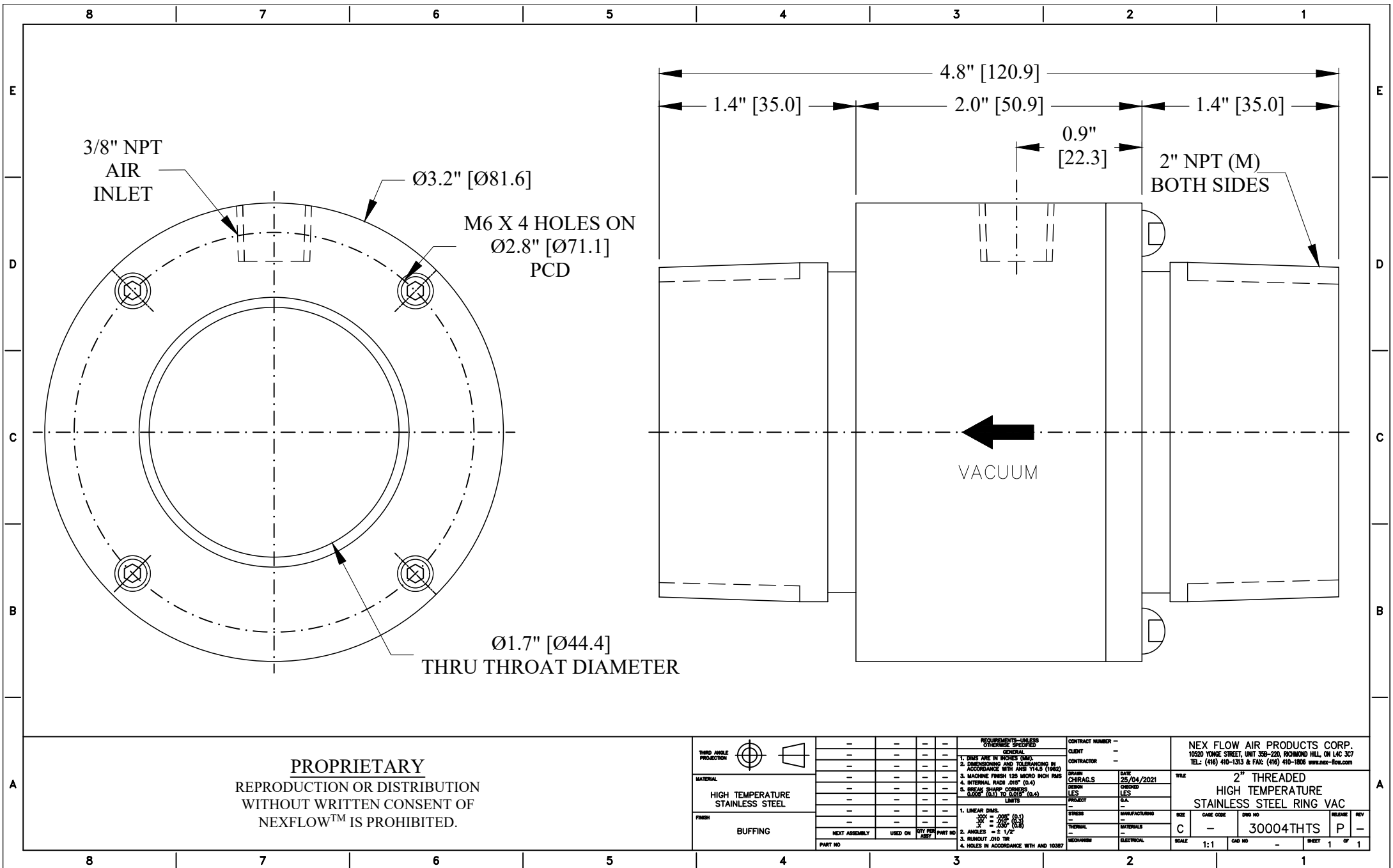

3/8" NPT  
AIR  
INLET

Ø3.2" [Ø81.6]

M6 X 4 HOLES ON  
Ø2.8" [Ø71.1]  
PCD

Ø1.7" [Ø44.4]  
THRU THROAT DIAMETER

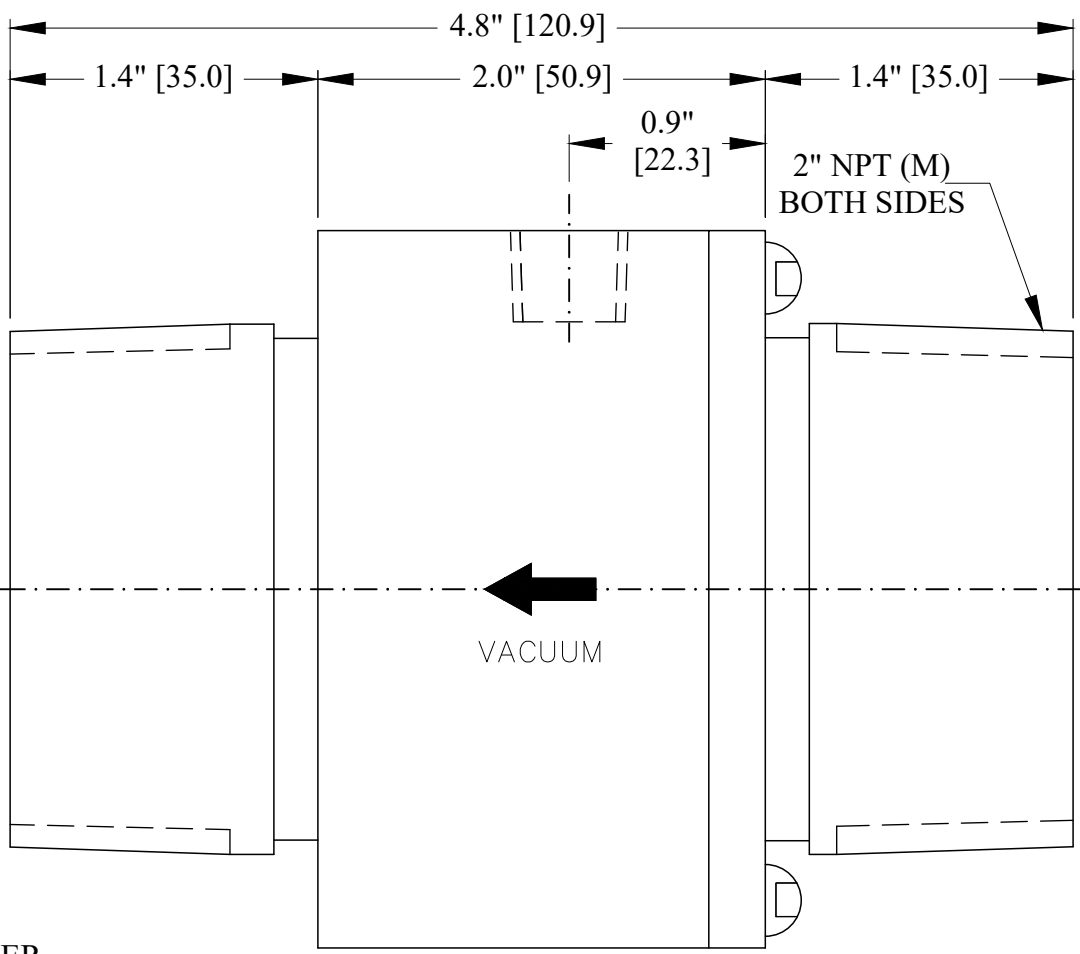

VACUUM

**PROPRIETARY**  
REPRODUCTION OR DISTRIBUTION  
WITHOUT WRITTEN CONSENT OF  
NEXFLOW™ IS PROHIBITED.

THIRD ANGLE PROJECTION		REQUIREMENTS—UNLESS OTHERWISE SPECIFIED				CONTRACT NUMBER —		NEX FLOW AIR PRODUCTS CORP. 10520 YONKE STREET, UNIT 339-220, RICHMOND HILL, ON L4C 3C7 TEL: (416) 410-1313 & FAX: (416) 410-1808 www.nex-flow.com					
		GENERAL				CLIENT	CONTRACTOR	DATE	TITLE				
MATERIAL	HIGH TEMPERATURE STAINLESS STEEL	1. DIMS ARE IN INCHES (MM) 2. DIMENSIONING AND TOLERANCING IN ACCORDANCE WITH ASME Y14.5 (1994)				DESIGN	DATE	2" THREADED HIGH TEMPERATURE STAINLESS STEEL RING VAC					
FRESH	BUFFING	3. MACHINE FRESH 125 MICRO INCH RMS 4. INTERNAL RADIUS .015" (0.4) 5. BREAK SHARP CORNERS 0.005" (0.1) TO 0.015" (0.4)				LES	DESIGN	CHANGED	SIZE	QAGE CODE	DWG NO	RELEASE	REV
		LIMITS				PROJECT	DATE						
		1. LINEAR DIMS. XXX = .0005 (0.3) YY = .0010 (0.8) ZZ = .0015 (0.8)				MANUFACTURING	DATE						
		2. ANGLES = ± 1/2°				MATERIALS	DATE						
		3. ROUNDT .010 TIR				ELECTRICAL	DATE						
		4. HOLES IN ACCORDANCE WITH AND 10387				Mechanism	DATE						
		NEXT ASSEMBLY	USED ON	DWG FOR	PART NO	SCALE	1:1	CAD NO	-	SHEET	1	OF	1

8 7 6 5 4 3 2 1

E

D

C

B

E

D

C

B

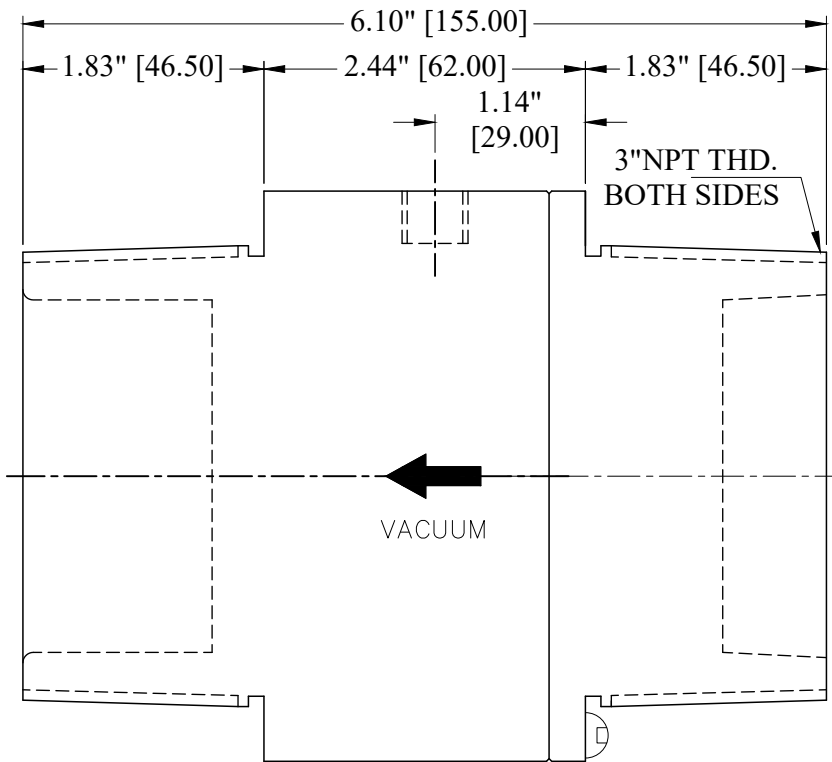
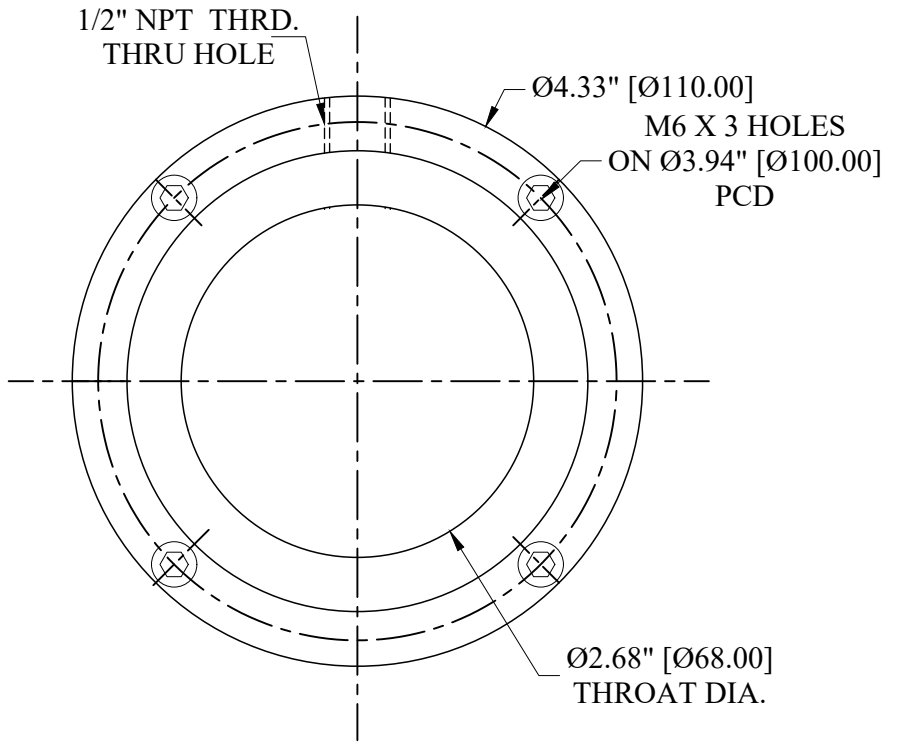

A

A

**PROPRIETARY**  
REPRODUCTION OR DISTRIBUTION  
WITHOUT WRITTEN CONSENT OF  
NEXFLOW™ IS PROHIBITED.

THIRD ANGLE PROJECTION					
MATERIAL	HIGH TEMPERATURE STAINLESS STEEL				
FINISH	BUFFING				
NEXT ASSEMBLY	USED ON	QTY PER ASSY	PART NO.		
PART NO.					

REQUIREMENTS—UNLESS OTHERWISE SPECIFIED	
GENERAL	
1. DIMS ARE IN INCHES (MM)	
2. DIMENSIONING AND TOLERANCING IN ACCORDANCE WITH ANSI Y14.5 (1982)	
3. MACHINE FINISH 125 MICRO INCH RMS	
4. INTERNAL RADI .015	
5. BREAK SHARP CORNERS .005 TO .015	
LIMITS	
1. LINEAR DIMS. + .004 - .010 X .030	
2. ANGLES = ± 1/2°	
3. RUNOUT .010 TIR	
4. HOLES IN ACCORDANCE WITH AND 10387	

CONTRACT NUMBER	—
CLIENT	—
CONTRACTOR	—
DRAWN	CHIRAG.S
DATE	25/04/2021
CHECKED	LES
PROJECT	D.A.
STRESS	—
MANUFACTURING	—
THERMAL	—
MATERIALS	—
MECHANICAL	—
ELECTRICAL	—

PROJECT	3" THREADED HIGH TEMPERATURE STAINLESS STEEL RING VAC
SIZE	C
SCALE	1:1
CAD NO.	30006THTS
SHEET	1 OF 1

NEX FLOW AIR PRODUCTS CORP. 10520 YONGE STREET, UNIT 358-220, RICHMOND HILL, ON L4C 3C7 TEL: (416) 410-1313 & FAX: (416) 410-1806 www.nex-flow.com	
DATE	25/04/2021
DESIGNER	LES
CHECKED	LES
PROJECT	D.A.
STRESS	—
MANUFACTURING	—
THERMAL	—
MATERIALS	—
MECHANICAL	—
ELECTRICAL	—
SCALE	1:1
CAD NO.	30006THTS
SHEET	1 OF 1

8 7 6 5 4 3 2 1