

SILENT X-STREAM™ AIR BLADE™ IONIZER

Powerful and quiet static eliminator rapidly dissipates static charge and removes dust.

The Silent X-Stream™ Air-Blade™ Air Knife utilizes the quality Haug static bars - the RN bar for most applications or the extra strong VS bars (Triple X versions) for very high static charges and extremely high speeds. The Silent X-Stream™ Air-Blade™ Air Knife uses a small amount of compressed air for a powerful, and adjustable force with "laminar" flow to eliminate charges in applications where static bars cannot reach or where high speeds are a factor, and to clean the surface.

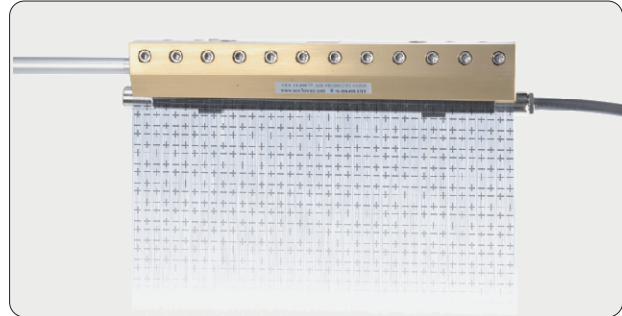

Normally the Standard Model RN Haug brand static bar can address most applications. For extremely high speeds and high charges the extra powerful VS model is used. For wash down applications (such as pharmaceutical areas), a washable model is available at extra cost. **(Contact factory for information)**

All Haug static bars come with a patented safety connector and fully shielded cable. The power supplies are "repairable" and are so well made, that we offer a two year warranty on them (one year on the bars).

SILENT X-STREAM™ AIR-BLADE™ IONIZER FEATURES:

- ▶ Connections on the back or ends
- ▶ It flows from end to end (full flow).
- ▶ Stainless steel models are available for high temperature and corrosive environments.
- ▶ Models are designed for easy cleaning and prevention of dirt entering the static bar, minimizing potential damage.
- ▶ Patented connectors with the ground intrinsic to the cable design.
- ▶ Instant ON/OFF with no moving parts.
- ▶ Repairable Power Supply with a two year warranty.

SILENT X-STREAM™ AIR-BLADE™ IONIZER BENEFITS:

- ▶ Flexible mounting options.
- ▶ Units can be mounted end to end for longer lengths with no air gap.
- ▶ High temperature, extra strength, and even a unique washable stainless steel model is available for special applications or as required.
- ▶ Ease of cleaning and maintenance.
- ▶ No separate ground connection that can be cut and cause sparks or accidentally shock personnel
- ▶ Conserves air use when not required.
- ▶ Eliminates one costly area which is power supply replacement. 2 year warranty on power supplies.

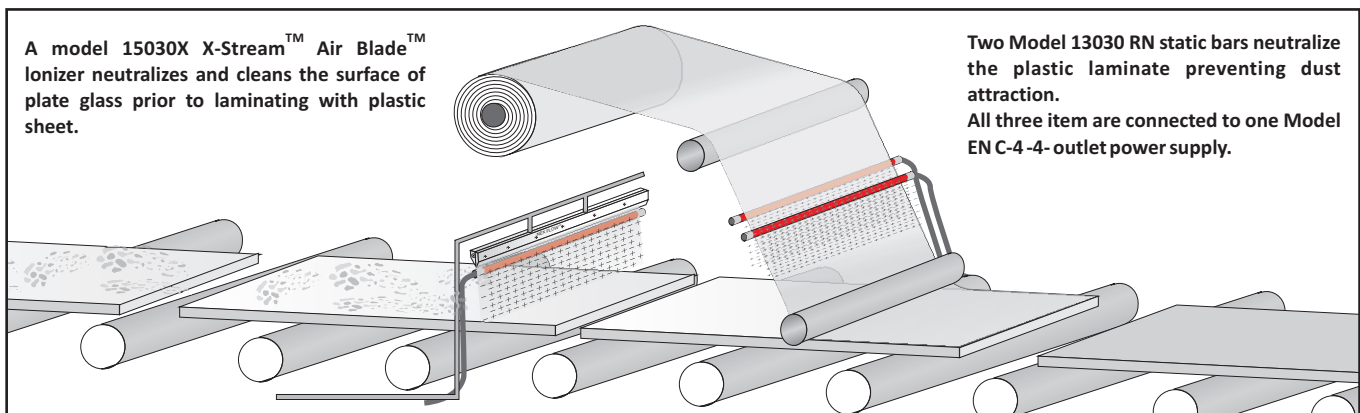

A model 15030X X-Stream™ Air Blade™ Ionizer neutralizes and cleans the surface of plate glass prior to laminating with plastic sheet.

Two Model 13030 RN static bars neutralize the plastic laminate preventing dust attraction. All three items are connected to one Model EN C-4 -4- outlet power supply.

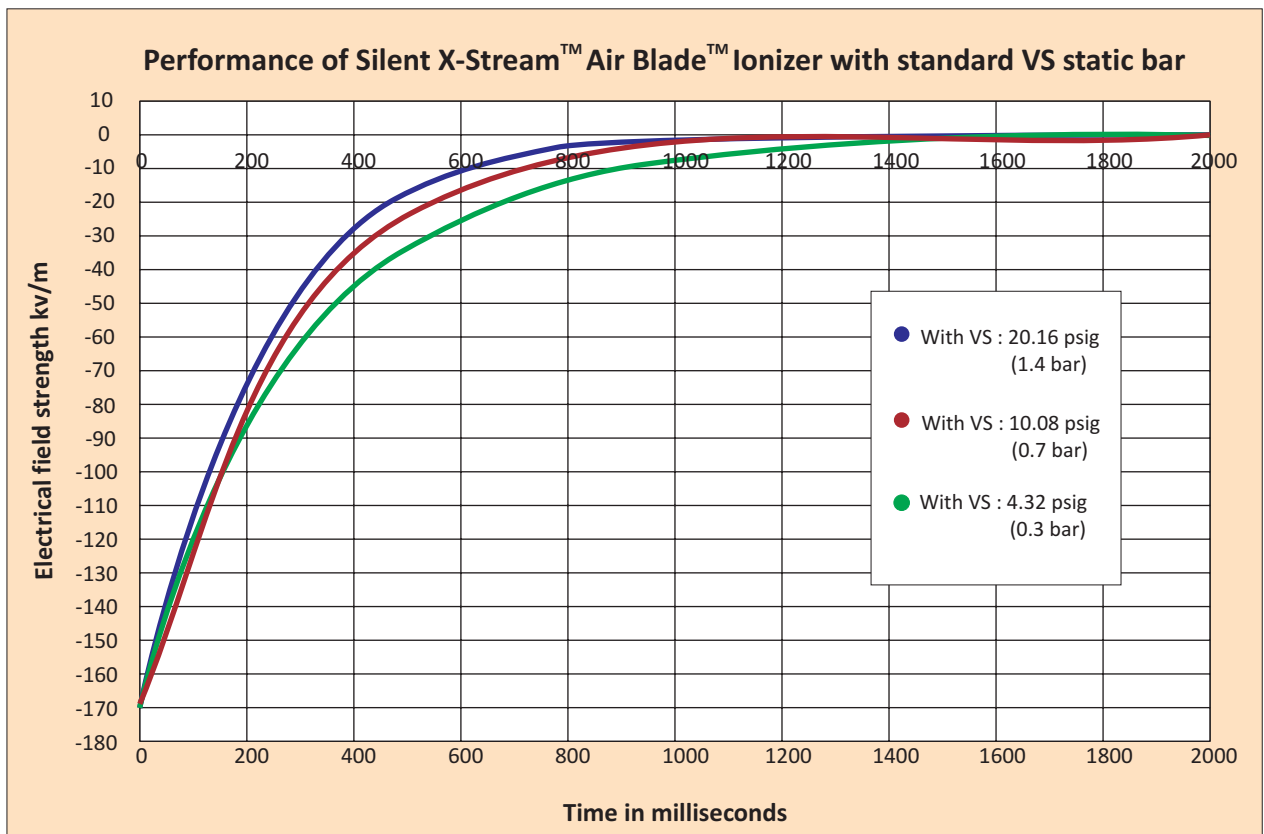
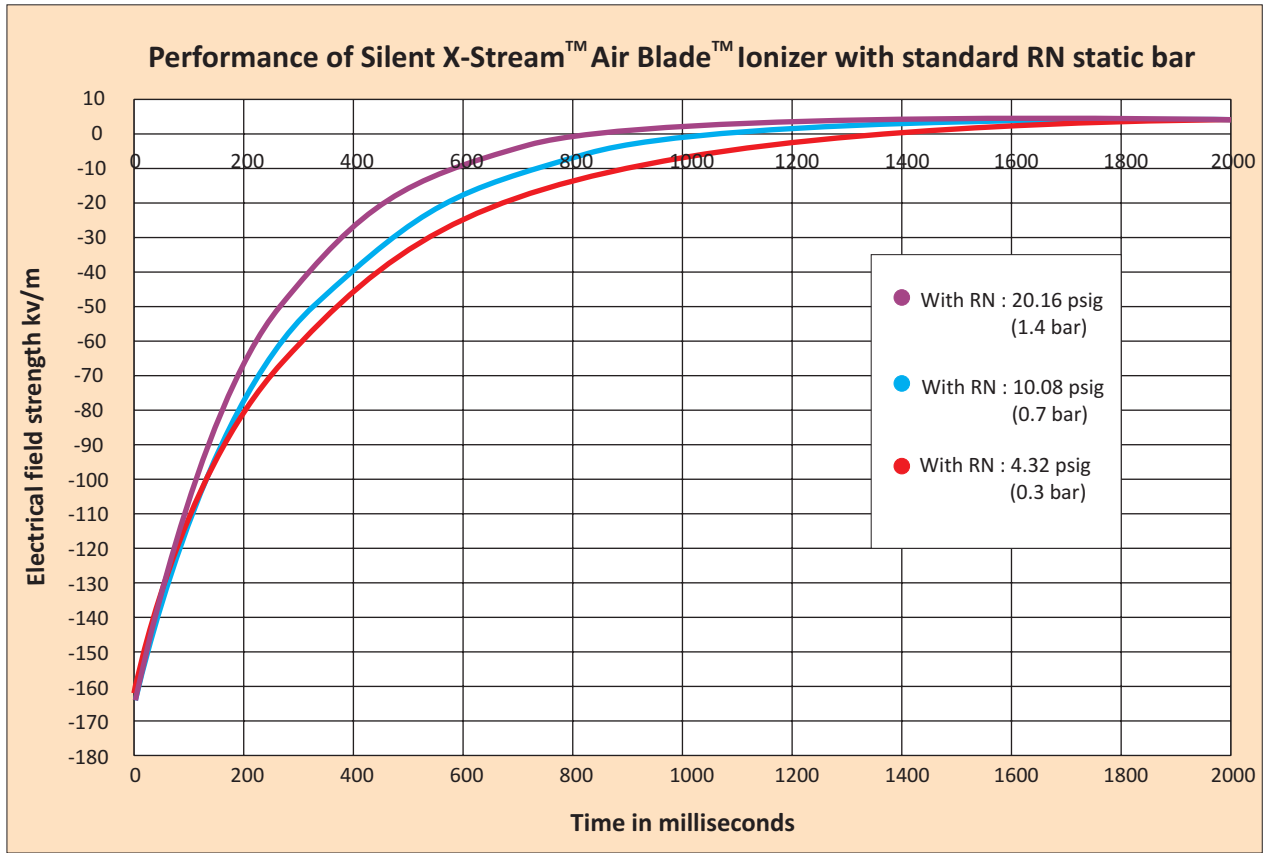

STATIC ELIMINATORS

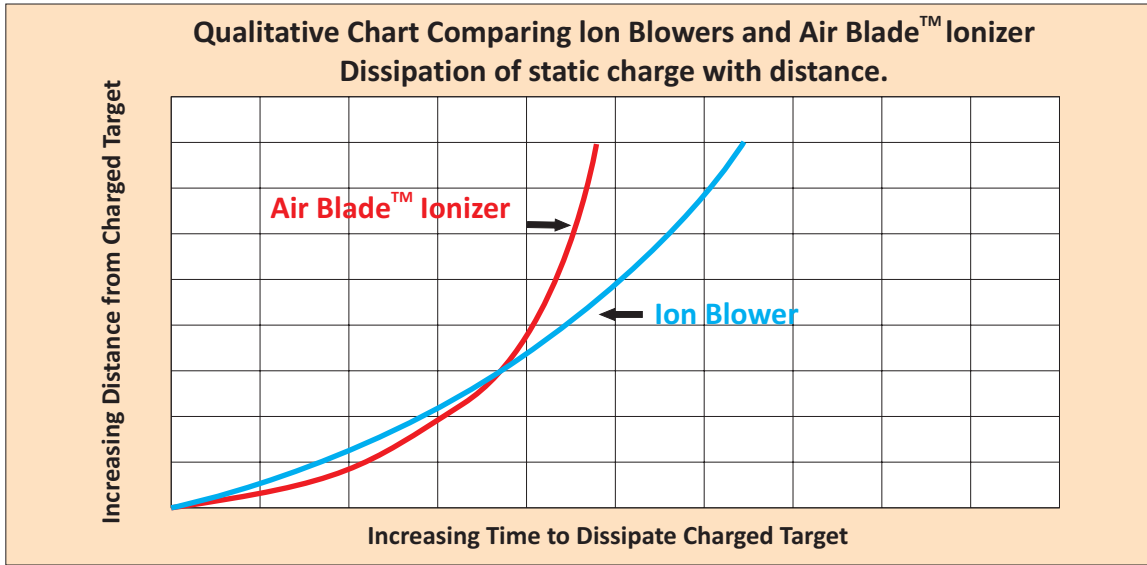

PERFORMANCE AND RELIABILITY

The standard RN static bar is very effective when mounted close to a surface (within an inch) at speeds up to 800 feet per minute and the strong VS bar can work to speeds up to 2000 feet per minute mounted as close or at slower speeds up to 8 inches away. For greater distances and high speeds the addition of air is required. The laminar flow from an Air Blade™ Air Knife will extend the effectiveness over this extra distance. Even with laminar flow the ions will recombine and slow static dissipation slightly. For very highly charged surfaces and very high speeds, the extra strong VS static bar may be required. Apart from distance, the Air Blade™ Air Knife allows enough force for blow-off of dust and dirt with little required. Blowers can actually be more effective in static removal closer to the surface but the Air Blade™ Ionizer is more effective when further away (see chart comparing blowers and Air Blade™ Ionizers above). This is why we recommend stronger static bars like our VS static bar for blowers when far from the target. Blowers however do not offer adequate blow-off force to clean unless they have very high flow and high static pressure. But when not close to the target, blower systems will still require a stronger static bar to match the rate of dissipation that an Air Blade™ Ionizer can offer. The X-Stream™ Air Blade™ Ionizer can work well for dust and dirt blow-off within the range of 20 to 40 PSIG (1.4 to 2.8 Bar) line pressure.

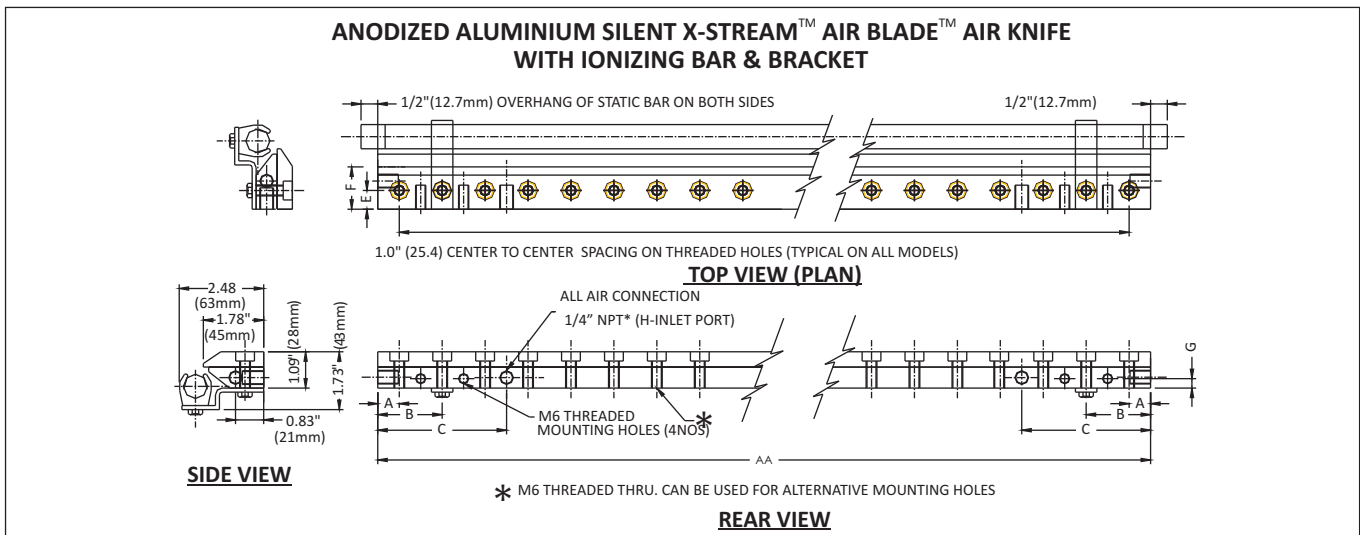

For Air Knife Dimensions please refer page B4

(* BSP Threads or Adaptors can be supplied depending on country location)

X-STREAM™ AIR BLADE™ IONIZERS

PART NO.	DESCRIPTION
15003X	One 3" X-Stream™ Air Blade™ c/w Model RN Static Bar
15006X	One 6" X-Stream™ Air Blade™ c/w Model RN Static Bar
15009X	One 9" X-Stream™ Air Blade™ c/w Model RN Static Bar
15012X	One 12" X-Stream™ Air Blade™ c/w Model RN Static Bar
15018X	One 18" X-Stream™ Air Blade™ c/w Model RN Static Bar
15024X	One 24" X-Stream™ Air Blade™ c/w Model RN Static Bar
15030X	One 30" X-Stream™ Air Blade™ c/w Model RN Static Bar
15036X	One 36" X-Stream™ Air Blade™ c/w Model RN Static Bar
15042X	One 42" X-Stream™ Air Blade™ c/w Model RN Static Bar
15048X	48" (Two 24") X-Stream™ Air Blade™ c/w Model RN Static Bar
15054X	54" (One 24" & One 30") X-Stream™ Air Blade™ c/w Model RN Static Bar
15060X	60" (Two 30") X-Stream™ Air Blade™ c/w Model RN Static Bar
15066X	66" (One 30" & One 36") X-Stream™ Air Blade™ c/w Model RN Static Bar
15072X	72" (Two 36") X-Stream™ Air Blade™ c/w Model RN Static Bar
15078X	78" (One 36" & One 42") X-Stream™ Air Blade™ c/w Model RN Static Bar
15084X	84" (Two 42") X-Stream™ Air Blade™ c/w Model RN Static Bar
15103X	3" X-Stream™ Air Blade™ Ionizer plus ENC-2 Power Supply
15106X	6" X-Stream™ Air Blade™ Ionizer plus ENC-2 Power Supply
15109X	9" X-Stream™ Air Blade™ Ionizer plus ENC-2 Power Supply
15112X	12" X-Stream™ Air Blade™ Ionizer plus ENC-2 Power Supply
15118X	18" X-Stream™ Air Blade™ Ionizer plus ENC-2 Power Supply
15124X	24" X-Stream™ Air Blade™ Ionizer plus ENC-2 Power Supply
15130X	30" X-Stream™ Air Blade™ Ionizer plus ENC-2 Power Supply
15136X	36" X-Stream™ Air Blade™ Ionizer plus ENC-2 Power Supply
15142X	42" X-Stream™ Air Blade™ Ionizer plus ENC-2 Power Supply
15148X	48" X-Stream™ Air Blade™ Ionizer plus ENC-2 Power Supply
15154X	54" X-Stream™ Air Blade™ Ionizer plus ENC-2 Power Supply
15160X	60" X-Stream™ Air Blade™ Ionizer plus ENC-2 Power Supply
15166X	66" X-Stream™ Air Blade™ Ionizer plus ENC-2 Power Supply
15172X	72" X-Stream™ Air Blade™ Ionizer plus ENC-2 Power Supply
15178X	78" X-Stream™ Air Blade™ Ionizer plus ENC-2 Power Supply
15184X	84" X-Stream™ Air Blade™ Ionizer plus ENC-2 Power Supply

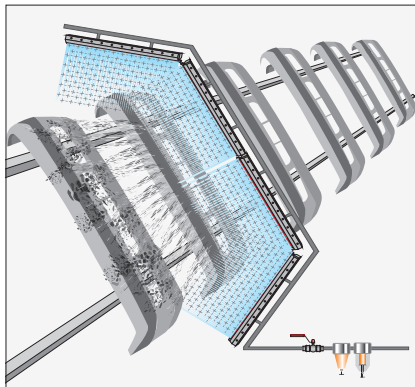

Three 24" X-Stream™ Air Blade™ Ionizers Blow off dust from Automotive Bumpers prior to painting. The NEX FLOW™ PLCFC controls the air on and off as required minimizing air consumption. In this case the static bars were "daisy-chained" together minimizing extraneous cable and reducing the number of power supplies needed.

STATIC ELIMINATORS

SUPER TRIPLE X-STREAM™ AIR BLADE™ IONIZERS

PART NO.	DESCRIPTION
16006X	One 6" Super Triple X-Stream™ Air Blade™ c/w Model VS Static Bar
16009X	One 9" Super Triple X-Stream™ Air Blade™ c/w Model VS Static Bar
16012X	One 12" Super Triple X-Stream™ Air Blade™ c/w Model VS Static Bar
16018X	One 18" Super Triple X-Stream™ Air Blade™ c/w Model VS Static Bar
16024X	One 24" Super Triple X-Stream™ Air Blade™ c/w Model VS Static Bar
15030X	One 30" Super Triple X-Stream™ Air Blade™ c/w Model VS Static Bar
16036X	One 36" Super Triple X-Stream™ Air Blade™ c/w Model VS Static Bar
16042X	One 42" Super Triple X-Stream™ Air Blade™ c/w Model VS Static Bar
16048X	48" (Two 24") Super Triple X-Stream™ Air Blade™ c/w Model VS Static Bar
16054X	54" (One 24" & One 30") Super Triple X-Stream™ Air Blade™ c/w Model VS Static Bar
16060X	60" (Two 30") Super Triple X-Stream™ Air Blade™ c/w Model VS Static Bar
16066X	66" (One 30" & One 36") Super Triple X-Stream™ Air Blade™ c/w Model VS Static Bar
16072X	72" (Two 36") Super Triple X-Stream™ Air Blade™ c/w Model VS Static Bar
16078X	78" (One 36" & One 42") Super Triple X-Stream™ Air Blade™ c/w Model VS Static Bar
16084X	84" (Two 42") Super Triple X-Stream™ Air Blade™ c/w Model VS Static Bar
16106X	6" Super Triple X-Stream™ Air Blade™ Ionizer plus ENC-2 Power Supply
16109X	9" Super Triple X-Stream™ Air Blade™ Ionizer plus ENC-2 Power Supply
16112X	12" Super Triple X-Stream™ Air Blade™ Ionizer plus ENC-2 Power Supply
16118X	18" Super Triple X-Stream™ Air Blade™ Ionizer plus ENC-2 Power Supply
16124X	24" Super Triple X-Stream™ Air Blade™ Ionizer plus ENC-2 Power Supply
16130X	30" Super Triple X-Stream™ Air Blade™ Ionizer plus ENC-2 Power Supply
16136X	36" Super Triple X-Stream™ Air Blade™ Ionizer plus ENC-2 Power Supply
16142X	42" Super Triple X-Stream™ Air Blade™ Ionizer plus ENC-2 Power Supply
16148X	48" Super Triple X-Stream™ Air Blade™ Ionizer plus ENC-2 Power Supply
16154X	54" Super Triple X-Stream™ Air Blade™ Ionizer plus ENC-2 Power Supply
16160X	60" Super Triple X-Stream™ Air Blade™ Ionizer plus ENC-2 Power Supply
16166X	66" Super Triple X-Stream™ Air Blade™ Ionizer plus ENC-2 Power Supply
16172X	72" Super Triple X-Stream™ Air Blade™ Ionizer plus ENC-2 Power Supply
16178X	78" Super Triple X-Stream™ Air Blade™ Ionizer plus ENC-2 Power Supply
16184X	84" Super Triple X-Stream™ Air Blade™ Ionizer plus ENC-2 Power Supply

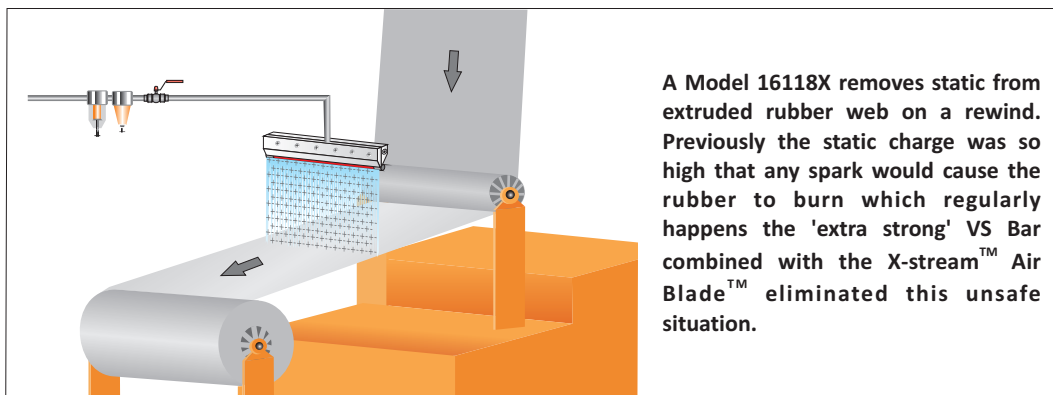

A Model 16118X removes static from extruded rubber web on a rewind. Previously the static charge was so high that any spark would cause the rubber to burn which regularly happens the 'extra strong' VS Bar combined with the X-stream™ Air Blade™ eliminated this unsafe situation.