

RING VAC™

Convey solid materials, waste, trim, small parts with virtually no moving parts

WHAT ARE THEY - REASONS TO USE

The Ring Vac™ - Pneumatic Conveying System has virtually no moving parts, conveys material at high rates and over long distances. They utilize only compressed air for a powerful, efficient venturi action along its length in a compact design for high capacity conveying over large distances. Ring Vacs are available in both coated aluminum or stainless steel. Simply clamp a standard hose size to each end of the Ring Vac™ to create this high energy conveying system. Threaded versions may be connected into standard pipe thread. No moving parts for maintenance free operation with capacity and flow controlled with a pressure regulator. Sizes are 3/8" (10mm), 1/2" (13mm), 3/4" (19mm), 1" (24.4mm), 1-1/4" (32mm), 1-1/2" (38mm) and 2" (51mm) and 3" (76.2mm). Any size beyond that can be prohibitive for most applications due to high compressed air requirements.

Beyond 3", the vacuum ability begins to drop significantly except for highly intermittent applications. However 3" units are available for such applications. Larger sizes are available on special order.

Anodized aluminum and high temperature stainless steel Ring Vac™ air conveyor can convey all types of solids in large volumes over great distances with no moving parts.

APPLICATIONS:

- ▶ Hopper Loading
- ▶ Material Conveying
- ▶ Trim Removal
- ▶ Transfer Parts
- ▶ Filling Operations
- ▶ Thread/fiber Tensioning

RING VAC™ BENEFITS:

- ▶ Longer life in difficult environments than competitive models.
- ▶ Ease of use.
- ▶ Simple and easy control of material flow.
- ▶ Maintenance free operation.

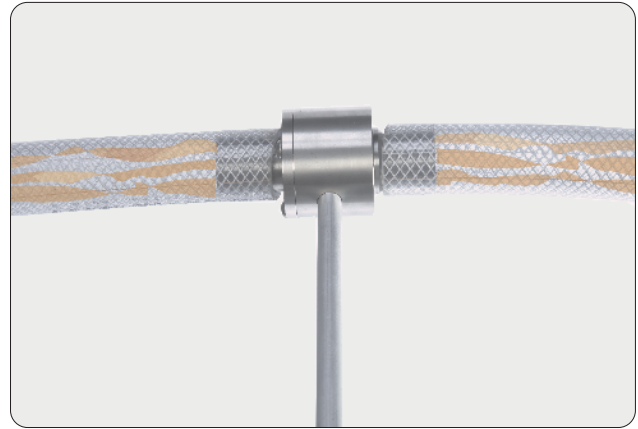

RING VAC™ FEATURES:

- ▶ Made of anodized aluminum with no moving parts. Regular and high temperature stainless steel models are available for higher temperature and corrosive environments. 316L stainless steel units from 1" to 3" are available with standard sanitary flanges for food pharmaceutical and other sanitary application.
- ▶ Standard sizes to fit standard hose diameter for easy clamping. Threaded versions connect easily to regular pipe thread : 1" (25mm), 1-1/4" (32mm), 1-1/2" (38mm), 2" (51mm). Special sizes can be manufactured if required.
- ▶ Utilizing a pressure regulator will control the flow material.
- ▶ Instant on/off with no moving parts, no electricity or explosion hazard.

A Model 30004S Stainless Steel 2" Ring Vac™ Air operated conveyor moves dried peas at a pet food manufacturing facility.

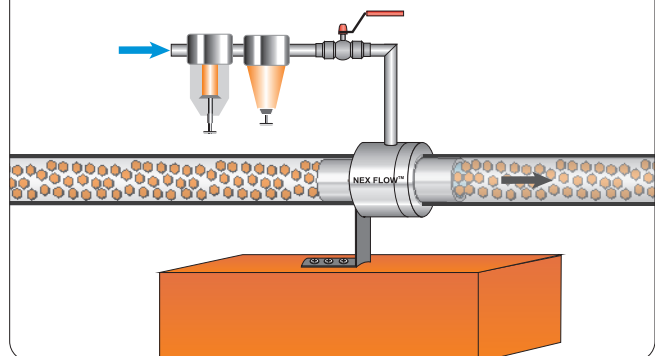

TYPES OF RING VACS

The Ring Vac™ Pneumatic Conveying System is available in anodized aluminum, 303/304 stainless steel and in 316L stainless steel. Our special high temperature stainless version is rated to 1200°F (649°C)

Unit with sanitary flanges for sanitary applications are 316L and comes in standard temperature version and high temperature versions for use up to 1200°F (649°C)

Regular models connect to a standard hose or tube to provide a powerful and simply in-line conveying system. Threaded versions thread directly into threaded pipe.

Special materials can be utilized for unique applications. If greater conveying force is required the conveying “generator” can be machined for higher capacities although they will use more compressed air.

An optional bracket allows for easy mounting.



SELECTION

The Ring Vac™ is available in a wide variety of sizes depending on your application. There are certain criteria to determine the size you need:

- ▶ Diameter of the parts that need to be conveyed
- ▶ Rate required for conveying (by weight or volume)
- ▶ Diameter of the tube, pipe or hose used
- ▶ Material- Aluminum, stainless or high temperature (To 1200°F (650°C)) stainless
- ▶ Hose connection with clamp or threaded unit



SPECIAL DESIGNS

The high temperature models are suited to temperatures up to 1200°F (650°C). One ideal use is for sampling flue gases. Special versions can be supplied with medical flanges, and specific materials, higher flow rates and vacuum depending on your application.

RING VAC™ - HOW IT WORKS:

Ring-Vac™ compressed air conveying system - Compressed air enters at point (A) into a annular plenum chamber and injected into the throat of the unit through directed nozzles. These jets of compressed air create a vacuum at the inlet (C) which draws in material and accelerates it through the unit and out at (D) conveying the material over a great vertical or horizontal distance.

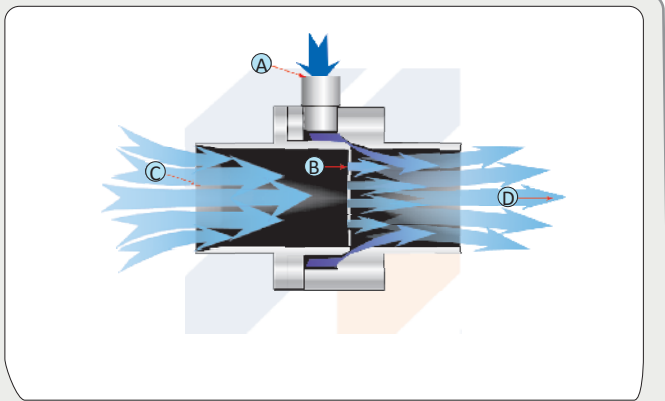

DIMENSIONS - NOTES ON PART NUMBERS:

S - stainless TS - threaded stainless THTS - high temperature threaded stainless
 T - threaded HTS - high temperature stainless

Dimensions in inches and (mm)

PART NUMBER (aluminum & stainless)	A IN (MM)	B IN (MM)	C IN (MM)	D IN (MM)	E IN (MM)	F IN (MM)	G IN (MM)	H IN (MM)	I IN (MM)	J IN (MM)	K IN (MM)	L
39998, 39998S 39998HTS	0.375" (10.0)	0.63" (16.0)	0.63" (16.0)	2.18" (65.0)	1.00" (25.0)	0.19" (5.0)	-	-	-	-	-	1/8" NPT
39999, 39999S 39999HTS	0.50" (13.0)	0.75" (19.0)	0.75" (25.4)	2.62" (19.0)	1.25" (32.0)	0.31" (8.0)	-	-	-	-	-	1/8" NPT
30000, 30000S, 30000HTS, 30000S-316L, 30000HTS-316L	0.75" (19.0)	1.00" (25.4)	1.00" (25.4)	3.94" (100.0)	1.95" (49.5)	0.55" (14.0)	1.92" (48.73)	0.95" (15.0)	0.39" (10.0)	1.18" (30.0)	1.97" (50.0)	1/4" NPT
30001, 30001S, 30001T 30001TS, 30001HTS 30001THTS, 30001S-316L 30001HTS-316L	1.00" (25.4)	1.38" (35.1)	1.50" (38.1)	4.88" (124.0)	2.24" (56.8)	0.75" (19.0)	2.17" (55.0)	0.73" (18.5)	0.39" (10.0)	1.58" (40.0)	1.97" (50.0)	1/4" NPT
30002, 30002S, 30002T 30002TS, 30002HTS 30002THTS, 30002S-316L 30002HTS-316L	1.25" (31.8)	1.38" (35.1)	1.50" (38.1)	4.88" (124.0)	2.49" (63.2)	1.00" (25.4)	2.21" (56.3)	0.73" (18.5)	0.39" (10.0)	1.77" (45.0)	2.17" (55.0)	1/4" NPT
30003, 30003S, 30003T 30003TS, 30003HTS 30003THTS, 30003S-316L 30003HTS-316L	1.50" (38.1)	1.38" (35.1)	1.50" (38.1)	4.88" (124.0)	2.75" (69.9)	1.125" (28.6)	2.15" (54.5)	0.89" (22.5)	0.39" (10.0)	1.58" (40.0)	1.97" (50.0)	3/8" NPT
30004, 30004S, 30004T 30004TS, 30004HTS 30004THTS, 30004S-316L 30004HTS-316L	2.00" (50.8)	1.38" (35.1)	1.50" (38.1)	4.88" (124.0)	3.21" (81.6)	1.75" (44.5)	2.39" (60.7)	1.18" (30.0)	0.39" (10.0)	1.58" (40.0)	1.97" (50.0)	3/8" NPT
30005, 30005S 30005HTS	2.50" (63.5)	1.38" (35.1)	1.50" (38.1)	5.29" (134.5)	3.94" (100.0)	2.19" (55.6)	-	-	-	-	-	3/8" NPT
30006, 30006S 30006TS, 30006HTS 30006THTS	3.0" (76.2)	1.58" (40.0)	1.58" (40.0)	5.59" (142.0)	4.33" (110.0)	2.68" (68.0)	-	-	-	-	-	1/2" NPT

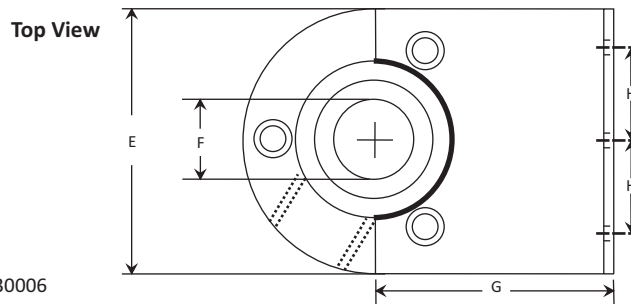

Series 30000 - 30006
Series 30001S - 30004S

Series 30001T - 30004T Threaded
Series 30001TS - 30004TS Threaded

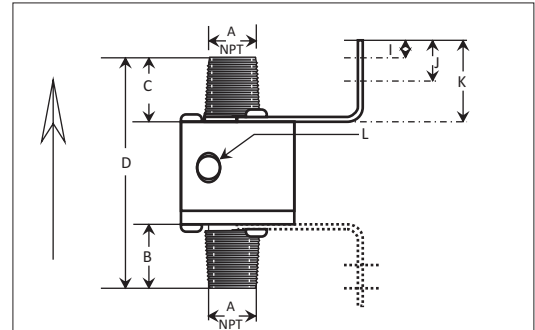
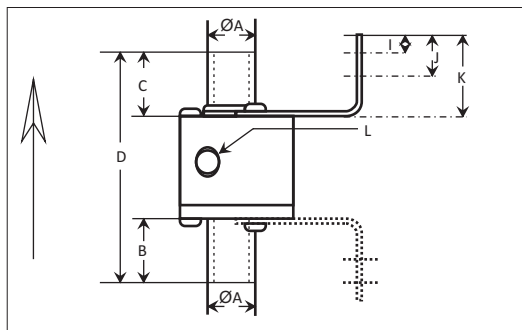

RING VAC™ AIR OPERATED CONVEYOR SYSTEMS



RING VAC™ PNEUMATIC CONVEYING SYSTEM PERFORMANCE:

MODEL	SIZE OUTSIDE DIAMETER INCHES (MM)	AIR CONSUMPTION SCFM AT 80 PSIG (SLPM AT 5.5 BAR)	VACUUM INCHES H2O (KPA)
39998/39998S/39998HTS	3/8" (10mm)	5.6 (158)	-120 (-29.9)
39999/39999S/39999HTS	1/2" (13mm)	7 (198)	-100 (-24.9)
30000/30000S/30000HTS	3/4" (19mm)	11 (303)	-72 (-18.0)
30000S-316L/30000HTS-316L			
30001/30001S/30001T/30001TS	1" (25mm)	15 (415)	-42 (-11)
30001HTS/30001THTS			
30001S-316L/30001HTS-316L			
30002/30002S/30002T/30002TS	1 1/4" (32mm)	26 (730)	-42 (-11)
30002SHTS/30002HTS			
30002S-316L/30002HTS-316L			
30003TS/30003THTS/30003HTS	1-1/2" (38mm)	33 (932)	-39 (-9)
30003THTS/30003S-316L/30003HTS-316L			
30004/30004S/30004T/30004TS	2" (51mm)	45 (1270)	-28 (-7)
30004HTS/30004THTS			
30004S-316L/30004HTS-316L			
30005/30005S/30005HTS	2-1/2" (63.5mm)	58.5 (1655)	-23.5 (-6)
30006/30006S/30006TS	3" (76mm)	69 (1940)	-14.7 (-4)
30006HTS/30006THTS			

RING VAC™ IN-LINE CONVEYERS: ALUMINUM RING VACS

PART NO.	DESCRIPTION
39998	3/8" Aluminum Ring Vac Only
39999	1/2" Aluminum Ring Vac™ Only
30000	3/4" Aluminum Ring Vac Only
30001	1" Aluminum Ring Vac™ Only
30002	1-1/4" Aluminum Ring Vac™ Only
30003	1-1/2" Aluminum Ring Vac™ Only
30004	2" Aluminum Ring Vac™ Only
30005	2-1/2" Aluminum Ring Vac™ Only
30006	3" Aluminum Ring Vac™ Only
31998	3/8" Aluminum Ring Vac™ Plus Filter with Auto Drain
31999	1/2" Aluminum Ring Vac™ Plus Filter with Auto Drain
31000	3/4" Aluminum Ring Vac™ Plus Filter with Auto Drain
31001	1" Aluminum Ring Vac™ plus Filter with Auto Drain
31002	1-1/4" Aluminum Ring Vac™ plus Filter with Auto Drain
31003	1-1/2" Aluminum Ring Vac™ plus Filter with Auto Drain
31004	2" Aluminum Ring Vac™ plus Filter with Auto Drain
31005	2-1/2" Aluminum Ring Vac™ Plus Filter with Auto Drain
31006	3" Aluminum Ring Vac™ Plus Filter with Auto Drain
32998	3/8" Aluminum Ring Vac Plus Filter with Auto Drain and Regulator with Gauge
32999	1/2" Aluminum Ring Vac Plus Filter with Auto Drain and Regulator with Gauge
32000	3/4" Aluminum Ring Vac Plus Filter with Auto Drain and Regulator with Gauge
32001	1" Aluminum Ring Vac™ plus Filter with Auto Drain & Regulator with Gauge
32002	1-1/4" Aluminum Ring Vac™ plus Filter with Auto Drain & Regulator with Gauge
32003	1-1/2" Aluminum Ring Vac™ plus Filter with Auto Drain & Regulator with Gauge
32004	2" Aluminum Ring Vac™ plus Filter with Auto Drain & Regulator with Gauge
32005	2-1/2" Aluminum Ring Vac™ Plus Filter with Auto Drain and Regulator with Gauge
32006	3" Aluminum Ring Vac™ Plus Filter with Auto Drain and Regulator with Gauge
30001T	1" Threaded Aluminum Ring Vac™ Only
30002T	1-1/4" Threaded Aluminum Ring Vac™ Only



RING VAC™ IN-LINE CONVEYERS : ALUMINUM RING VACS (CON'T)

PART NO.	DESCRIPTION
30003T	1-1/2" Threaded Aluminum Ring Vac™ Only
30004T	2" Threaded Aluminum Ring Vac™ Only
31001T	1" Threaded Aluminum Ring Vac™ plus Filter with Auto Drain
31002T	1-1/4" Threaded Aluminum Ring Vac™ plus Filter with Auto Drain
31003T	1-1/2" Threaded Aluminum Ring Vac™ plus Filter with Auto Drain
31004T	2" Threaded Aluminum Ring Vac™ plus Filter with Auto Drain
32001T	1" Threaded Aluminum Ring Vac™ & Filter + Auto Drain & Regulator with Gauge
32002T	1-1/4" Threaded Alum. Ring Vac™ & Filter + Auto Drain & Regulator with Gauge
32003T	1-1/2" Threaded Alum. Ring Vac™ & Filter + Auto Drain & Regulator with Gauge
32004T	2" Threaded Aluminum Ring Vac™ & Filter + Auto Drain & Regulator with Gauge

RING VAC™ IN-LINE CONVEYERS : STAINLESS STEEL RING-VACS

PART NO.	DESCRIPTION
39998S	3/8" Stainless Ring Vac™ Only
39999S	1/2" Stainless Ring Vac™ Only
30000S	3/4" Stainless Ring Vac™ Only
30001S	1" Stainless Ring Vac™ Only
30002S	1-1/4" Stainless Ring Vac™ Only
30003S	1-1/2" Stainless Ring Vac™ Only
30004S	2" Stainless Ring Vac™ Only
30005S	2-1/2" Stainless Ring Vac™ Only
30006S	3" Stainless Ring Vac™ Only
31998S	3/8" Stainless Ring Vac™ plus Filter with Auto Drain
31999S	1/2" Stainless Ring Vac™ plus Filter with Auto Drain
31000S	3/4" Stainless Ring Vac™ plus Filter with Auto Drain
31001S	1" Stainless Ring Vac™ plus Filter with Auto Drain
31002S	1-1/4" Stainless Ring Vac™ plus Filter with Auto Drain
31003S	1-1/2" Stainless Ring Vac™ plus Filter with Auto Drain
31004S	2" Stainless Ring Vac™ plus Filter with Auto Drain
31005S	2-1/2" Stainless Ring Vac™ plus Filter with Auto Drain
31006S	3" Stainless Ring Vac™ plus Filter with Auto Drain
32998S	3/8" Stainless Ring Vac™ plus Filter with Auto Drain & Regulator with Gauge
32999S	1/2" Stainless Ring Vac™ plus Filter with Auto Drain & Regulator with Gauge
32000S	3/4" Stainless Ring Vac™ plus Filter with Auto Drain & Regulator with Gauge
32001S	1" Stainless Ring Vac™ plus Filter with Auto Drain & Regulator with Gauge
32002S	1-1/4" Stainless Ring Vac™ plus Filter with Auto Drain & Regulator with Gauge
32003S	1-1/2" Stainless Ring Vac™ plus Filter with Auto Drain & Regulator with Gauge
32004S	2" Stainless Ring Vac™ plus Filter with Auto Drain & Regulator with Gauge
32005S	2-1/2" Stainless Ring Vac™ plus Filter with Auto Drain & Regulator with Gauge
32006S	3" Stainless Ring Vac™ plus Filter with Auto Drain & Regulator with Gauge
30001TS	1" Threaded Stainless Ring Vac™ Only
30002TS	1-1/4" Threaded Stainless Ring Vac™ Only
30003TS	1-1/2" Threaded Stainless Ring Vac™ Only



RING VAC™ IN-LINE CONVEYERS : STAINLESS STEEL RING-VACS (Con't)

PART NO.	DESCRIPTION
30004TS	2" Threaded Stainless Ring Vac™ Only
30006TS	3" Threaded Stainless Ring Vac™ Only
31001TS	1" Threaded Stainless Ring Vac™ plus Filter with Auto Drain
31002TS	1-1/4" Threaded Stainless Ring Vac™ plus Filter with Auto Drain
31003TS	1-1/2" Threaded Stainless Ring Vac™ plus Filter with Auto Drain
31004TS	2" Threaded Stainless Ring Vac™ plus Filter with Auto Drain
31006TS	3" Threaded Stainless Ring Vac™ plus Filter with Auto Drain
32001TS	1" Threaded Stainless Ring Vac™ & Filter + Auto Drain & Regulator with Gauge
32002TS	1-1/4" Threaded SS. Ring Vac™ & Filter + Auto Drain & Regulator with Gauge
32003TS	1-1/2" Threaded SS. Ring Vac™ & Filter + Auto Drain & Regulator with Gauge
32004TS	2" Threaded Stainless Ring Vac™ & Filter + Auto Drain & Regulator with Gauge
32006TS	3" Threaded Stainless Ring Vac™ & Filter + Auto Drain & Regulator with Gauge

RING VAC™ IN-LINE CONVEYERS : HIGH TEMPERATURE STAINLESS STEEL RING VACS

PART NO.	DESCRIPTION
39998HTS	3/8" High Temperature Stainless Ring Vac™ Only
39999HTS	1/2" High Temperature Stainless Ring Vac™ Only
30000HTS	3/4" High Temperature Stainless Ring Vac™ Only
30001HTS	1" High Temperature Stainless Ring Vac™ Only
30002HTS	1-1/4" High Temperature Stainless Ring Vac™ Only
30003HTS	1-1/2" High Temperature Stainless Ring Vac™ Only
30004HTS	2" High Temperature Stainless Ring Vac™ Only
30005HTS	2-1/2" High Temperature Stainless Ring Vac™ Only
30006HTS	3" High Temperature Stainless Ring Vac™ Only
31998HTS	3/8" High Temperature Stainless Ring Vac™ plus Filter with Auto Drain
31999HTS	1/2" High Temperature Stainless Ring Vac™ plus Filter with Auto Drain
31000HTS	3/4" High Temperature Stainless Ring Vac™ plus Filter with Auto Drain
31001HTS	1" High Temperature Stainless Ring Vac™ plus Filter with Auto Drain
31002HTS	1-1/4" High Temperature Stainless Ring Vac™ plus Filter with Auto Drain
31003HTS	1-1/2" High Temperature Stainless Ring Vac™ plus Filter with Auto Drain
31004HTS	2" High Temperature Stainless Ring Vac™ plus Filter with Auto Drain
31005HTS	2-1/2" High Temperature Stainless Ring Vac™ plus Filter with Auto Drain
31006HTS	3" High Temperature Stainless Ring Vac™ plus Filter with Auto Drain
32998HTS	3/8" High Temp. SS. Ring Vac™ plus Filter + Auto Drain & Regulator with Gauge
32999HTS	1/2" High Temp. SS. Ring Vac™ plus Filter + Auto Drain & Regulator with Gauge
32000HTS	3/4" High Temp. SS. Ring Vac™ plus Filter + Auto Drain & Regulator with Gauge
32001HTS	1" High Temp. SS. Ring Vac™ plus Filter + Auto Drain & Regulator with Gauge
32002HTS	1-1/4" High Temp. SS. Ring Vac™ plus Filter + Auto Drain & Regulator with Gauge
32003HTS	1-1/2" High Temp. SS. Ring Vac™ plus Filter + Auto Drain & Regulator with Gauge



RING VAC™ IN-LINE CONVEYERS: HIGH TEMPERATURE STAINLESS STEEL RING VACS (Con't)

PART NO.	DESCRIPTION
32004HTS	2" High Temp. SS. Ring Vac™ plus Filter + Auto Drain & Regulator with Gauge
32005HTS	2-1/2" High Temp. SS. Ring Vac™ plus Filter + Auto Drain & Regulator with Gauge
32006HTS	3" High Temp. SS. Ring Vac™ plus Filter + Auto Drain & Regulator with Gauge
30001THTS	1" High Temperature Threaded Stainless Ring Vac™ Only
30002THTS	1-1/4" High Temperature Threaded Stainless Ring Vac™ Only
30003THTS	1-1/2" High Temperature Threaded Stainless Ring Vac™ Only
30004THTS	2" High Temperature Threaded Stainless Ring Vac™ Only
30006THTS	3" High Temperature Threaded Stainless Ring Vac™ Only
31001THTS	1" High Temp. Threaded SS. Ring Vac™ plus Filter with Auto Drain
31002THTS	1-1/4" High Temp. Threaded SS. Ring Vac™ plus Filter with Auto Drain
31003THTS	1-1/2" High Temp. Threaded SS. Ring Vac™ plus Filter with Auto Drain
31004THTS	2" High Temp. Threaded SS. Ring Vac™ plus Filter with Auto Drain
31006THTS	3" High Temp. Threaded SS. Ring Vac™ plus Filter with Auto Drain
32001THTS	1" High Temp. Threaded SS. Ring Vac™ & Filter + Auto Drain & Regulator with Gauge
32002THTS	1-1/4" High Temp. Threaded SS. Ring Vac™ & Filter + Auto Drain & Regulator with Gauge
32003THTS	1-1/2" High Temp. Threaded SS. Ring Vac™ & Filter + Auto Drain & Regulator with Gauge
32004THTS	2" High Temp. Threaded SS. Ring Vac™ & Filter + Auto Drain & Regulator with Gauge
32006THTS	3" High Temp. Threaded SS. Ring Vac™ & Filter + Auto Drain & Regulator with Gauge
30000S-316L	3/4" 316L Stainless Ring Vac™ Only
30000S-316L	1" 316L Stainless Ring Vac™ Only
30001S-316L	1-1/4" 316L Stainless Ring Vac™ Only
30002S-316L	1-1/2" 316L Stainless Ring Vac™ Only
30003S-316L	2" 316L Stainless Ring Vac™ Only
31000S-316L	3/4" 316L Stainless Ring Vac™ plus Filter with Auto Drain
31001S-316L	1" 316L Stainless Ring Vac™ plus Filter with Auto Drain
31002S-316L	1-1/4" 316L Stainless Ring Vac™ plus Filter with Auto Drain
31003S-316L	1-1/2" 316L Stainless Ring Vac™ plus Filter with Auto Drain
31004S-316L	2" 316L Stainless Ring Vac™ plus Filter with Auto Drain
32000S-316L	3/4" 316L Stainless Ring Vac™ plus Filter with Auto Drain & Regulator with Gauge
32001S-316L	1" 316L Stainless Ring Vac™ plus Filter with Auto Drain & Regulator with Gauge
32002S-316L	1-1/4" 316L Stainless Ring Vac™ plus Filter with Auto Drain & Regulator with Gauge

RING VAC™ AIR OPERATED CONVEYOR SYSTEMS

RING VAC™ IN-LINE CONVEYERS: HIGH TEMPERATURE STAINLESS STEEL RING VACS (Con't)

PART NO.	DESCRIPTION
32003S-316L	1-1/2" 316L Stainless Ring Vac™ plus Filter with Auto Drain & Regulator with Gauge
32004S-316L	2" 316L Stainless Ring Vac™ plus Filter with Auto Drain & Regulator with Gauge
30000HTS-316L	3/4" 316L High Temperature Stainless Ring Vac™ Only
30001HTS-316L	1" 316L High Temperature Stainless Ring Vac™ Only
30002HTS-316L	1-1/4" 316L High Temperature Stainless Ring Vac™ Only
30003HTS-316L	1-1/2" 316L High Temperature Stainless Ring Vac™ Only
30004HTS-316L	2" 316L High Temperature Stainless Ring Vac™ Only
31000HTS-316L	3/4" 316L High Temperature Stainless Ring Vac™ + Filter with Auto Drain
31001HTS-316L	1" 316L High Temperature Stainless Ring Vac™ + Filter with Auto Drain
31002HTS-316L	1-1/4" 316L High Temperature Stainless Ring Vac™ + Filter with Auto Drain
31003HTS-316L	1-1/2" 316L High Temperature Stainless Ring Vac™ + Filter with Auto Drain
31004HTS-316L	2" 316L High Temperature Stainless Ring Vac™ + Filter with Auto Drain
32000HTS-316L	3/4" 316L High Temp. Stainless Ring Vac™ + Filter with Auto Drain & Regulator with Drain
32001HTS-316L	1" 316L High Temp. Stainless Ring Vac™ + Filter with Auto Drain & Regulator with Drain
32002HTS-316L	1-1/4" 316L High Temp. Stainless Ring Vac™ + Filter with Auto Drain & Regulator with Drain
32003HTS-316L	1-1/2" 316L High Temp. Stainless Ring Vac™ + Filter with Auto Drain & Regulator with Drain
32004HTS-316L	2" 316L High Temp. Stainless Ring Vac™ + Filter with Auto Drain & Regulator with Drain

PART NO.	DESCRIPTION
30001S-316L-SAN	1" 316L Stainless Steel Ring-Vac™ Only with Sanitary Flange
30002S-316L-SAN	1-1/4" 316L Stainless Steel Ring-Vac™ Only with Sanitary Flange
30003S-316L-SAN	1-1/2" 316L Stainless Steel Ring-Vac™ Only with Sanitary Flange
30004S-316L-SAN	2" 316L Stainless Steel Ring-Vac™ Only with Sanitary Flange
30005S-316L-SAN	2-1/2" 316L Stainless Steel Ring-Vac™ Only with Sanitary Flange
30006S-316L-SAN	3" 316L Stainless Steel Ring-Vac™ Only with Sanitary Flange

PART NO.	DESCRIPTION
30001HTS-316L-SAN	1" 316L Stainless Steel Ring-Vac High temp. Only with Sanitary Flange
30002HTS-316L-SAN	1-1/4" 316L Stainless Steel Ring-Vac High temp. Only with Sanitary Flange
30003HTS-316L-SAN	1-1/2" 316L Stainless Steel Ring-Vac High temp. Only with Sanitary Flange
30004HTS-316L-SAN	2" 316L Stainless Steel Ring-Vac High temp. Only with Sanitary Flange
30005HTS-316L-SAN	2-1/2" 316L Stainless Steel Ring-Vac High temp. Only with Sanitary Flange
30006HTS-316L-SAN	3" 316L Stainless Steel Ring-Vac High temp. Only with Sanitary Flange

PART NO.	DESCRIPTION
39000S	Stainless Steel Bracket for 30000, 30000S and 30000HTS
39001S	Stainless Steel Bracket for 30001, 30001T, 30001S, 30001TS, 30001HTS, 30001THTS
39002S	Stainless Steel Bracket for 30002, 30002T, 30002S, 30002TS, 30002HTS, 30002THTS
39003S	Stainless Steel Bracket for 30003, 30003T, 30003S, 30003TS, 30003HTS, 30003THTS
39004S-A	Stainless Steel Bracket for 30004 and 30004T
39004S-S	Stainless Steel Bracket for 30004S, 30004TS, 30004HTS, 30004THTS

