

AIR EDGER™ FLAT JET NOZZLE

Superior designed Flat Jet Nozzle reduces compressed air consumption and noise levels

– with the use of different shims can vary the force from weak to strong depending on the application

WHAT ARE THEY - REASONS TO USE

Model **47011** (cast zinc) **Air Edger™ Flat Jet** and Model **47011S-316L** (316L stainless steel) is an extremely efficient flat jet air nozzle designed to provide a powerful stream of high velocity laminar flow and high force for blow off and cooling where air knives may not be enough

When bench tested against several other flat jets, even those with special designed holes or shims, the **Air Edger™ Flat jet** outperformed them all despite whatever claims others may make. Air consumption and noise levels are minimized with its special design and configuration.

NOISE LEVELS (dBA) :

47011-4	75 dBA
47011-8	76 dBA
47011-12	77 dBA
47011-16	78 dBA
47011-20	80 dBA
47011-24	82 dBA
47011-28	83 dBA



The **Nex Flow™ Air Edger™ Flat Jet** is available with various size “gaps” all set by a flat shim. Three standard shim sizes are available - .004” (.10 mm), .008” (.2mm) and .020” (.51 mm). One, two or more shims can be “stacked” for a larger gap and greater force.



Air Edger™ Flat Jet with .008” gap setting blows water from under the caps on a bottling line moving at high speed



Air Edger™ Flat Jet with .020” gap setting provides a powerful force to blow off dirt and debris in an extrusion line

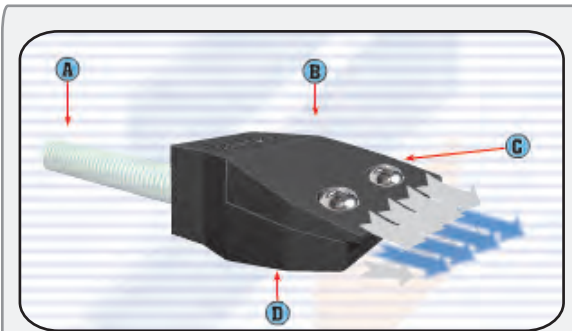

HOW IT WORKS

Compressed air enters the flat jet at the rear port at (A). Air is entrained at point (B) and (D) by the compressed air stream that leaves the flat jet from a small gap at the end. The entrained air follows the profile that directs the airflow in a perfect straight line to create a uniform sheet of air along the 2” length of the Air Edger™ Flat Jet Nozzle. The amplified air stream maximizes velocity and force to produce a well-defined sharp edge laminar flow with minimal wind shear for reduced energy use in blow off and cooling. Two screws at (C) allow you to vary the gap with a variety of sizes of shims (.004”, .008” or .020”). One or two shims may be used.

PERFORMANCE

AIR CONSUMPTION AND FORCE

MODEL Cast Aluminum	MODEL 316L Stainless	SCFM (SLPM) at 80 PSIG Measured at entrance to jet	FORCE in Ounces (grams) at 12" from target
Model 47011-4	Model 47011S-316L-4	20.5 (581)	12 (340)
Model 47011-8	Model 47011S-316L-8	31.3(887)	21 (595)
Model 47011-12	Model 47011S-316L-12	38.5 (1091)	27 (765)
Model 47011-16	Model 47011S-316L-16	41.0 (1161)	30 (850)
Model 47011-20	Model 47011S-316L-20	44.5 (1261)	33 (936)
Model 47011-24	Model 47011S-316L-24	47.0 (1331)	36(1020)
Model 47011-28	Model 47011S-316L-28	51.0 (1445)	39 (1106)



The Air Edger™ Flat Jet Nozzle air gap is set by one or more shims. There are three basic shim sizes - .004" (.1 mm), .008" (.2 mm) and .020" (.5 mm). Shims may be stacked for larger gaps and for sizes in between the shim standard sizes offered. Shims available in both 304 stainless steel & 316L stainless (for the stainless Air Edger™). The greater the gap the more powerful the force.

DIMENSIONS

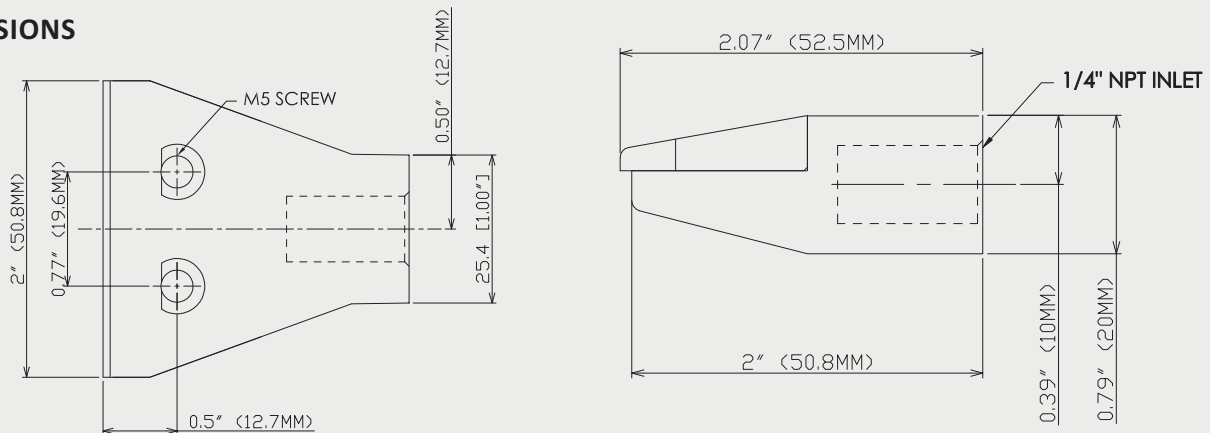

COMPARED TO COMPETITION

It is not always clear how tests and measurements are made by competitors and therefore validating claims can be difficult since such values depend on how tests are done. Therefore we measured a competitive unit under the same conditions as we measured our units. The flat jet of the competitor is of a similar type except that they are using a saw tooth shim design and different internal dimensions. We obtained the following readings when measured using the same parameters as for Nex Flow units.

25.1 SCFM AIR CONSUMPTION AND 15 oz force
(Published figures were 22 SCFM and 22 oz force)

One measure of efficiency is the ratio of Force/Air Consumption. The higher the ratio the better the efficiency. The force/SCFM is a ratio of .54 based on measured figures when measured the same way as the Nex Flow units.

If we compare to that of the Nex Flow Model 47011-4 the ratio is 12/20.5 = .58 And for the Model 47011-8 the ratio is 21/31.3 = .67 In both cases the efficiency of the Nex Flow units are higher in the comparative tests done under the same conditions.

FLAT JET NOZZLES	
PART NO.	DESCRIPTION
47011-4 & 47011S-316L-4	Air Edger™ Flat Jet with .004" gap setting
47011-8 & 47011S-316L-8	Air Edger™ Flat Jet with .008" gap setting
47011-12 & 47011S-316L-12	Air Edger™ Flat Jet with .012" gap setting
47011-16 & 47011S-316L-16	Air Edger™ Flat Jet with .016" gap setting
47011-20 & 47011S-316L-20	Air Edger™ Flat Jet with .020" gap setting
47011-24 & 47011S-316L-24	Air Edger™ Flat Jet with .024" gap setting
47011-28 & 47011S-316L-28	Air Edger™ Flat Jet with .028" gap setting
47111S-4	.004" 304 stainless steel shim
47111S-8	.008" 304 stainless steel shim
47111S-20	.020" 304 stainless steel shim
47211S	304 stainless steel shim set – Two (2) .004", Two (2) .008" and One (1) .020" shim
47111S-316L-4	.004" 316L stainless steel shim
47111S-316L-8	.008" 316L stainless steel shim
47111S-316L-20	.020" 316L stainless steel shim
47211S-316L	316L stainless steel shim set – Two (2) .004", Two (2) .008" and One (1) .020" shim

NOT SURE OF THE SIZE YOU NEED?

If you are not sure of which level of power you need, we recommend a Model 47211S Shim Set (for the cast zinc model) or a Model 47211S-316L Shim Set (for the 316L stainless steel model). The shim set consists of 2 - .004" shims, 2 - .008" shims and 1 - .020" shim and any two shims (or more) can be stacked to set the gap best suited to your application.

RIGID FLEX HOSE NOZZLE ACCESSORIES - TO HOLD AND AIM NOZZLES AND JETS



The unique Nex Flow™ RIGID FLEX hose is an all stainless steel hose that does not break after a few bends like competitive rubber hoses with simple copper inserts. It is resistant to creep and crimping. Its all stainless construction allows it use in any difficult environment. They have ¼" male NPT welded end connections and come in 6", 12" and 18" overall lengths.



STAINLESS STEEL RIGID FLEX HOSE (REFER TO PAGE M5 FOR THE RIGID FLEX HOSE)

PART NO.	DESCRIPTION
6RF (MM / MF)	6" Stainless Steel Rigid Hose which can be flexed to a shape
12RF (MM / MF)	12" Stainless Steel Rigid Hose which can be flexed to a shape
18RF (MM / MF)	18" Stainless Steel Rigid Hose which can be flexed to a shape