

INSTALLATION GUIDELINES

1. Maintain line pressure at 80 to 100 PSIG (5.5 to 6 bar)
2. Keep compressed air lines sized adequately to minimize pressure drop. For lengths to 50 feet use ¼" pipe or 3/8" hose. For lengths to 100 feet use 3/8" pipe or ½" hose. Do not use any fittings that can restrict air flow such as quick disconnects.
3. Use adequate filtration to keep air line free of moisture and dirt. Recommended water removal filter should be 10 micron or 5 micron. Recommended oil removal filter should be 0.3 micron. Filters should have a float type automatic drain.

USE OF THE FRIGID-X™ MINI SPOT COOLER SYSTEM

1. Mount the unit where appropriate to be able to direct the cold air onto the part or spot to be cooled using the flexible hose provided in the kit.
2. Both the fan nozzle and cone nozzle are supplied. Make sure the nozzle is close to the area to be cooled as possible and try to be within ½" of the part.
3. Keep the length of the hose distribution as short as possible to minimize loss of cooling effect due to conduction.

FRIGID-X™ MINI SPOT COOLER INSTALLATION & MAINTENANCE

TROUBLESHOOTING AND MAINTENANCE OF THE UNIT

1. **INLET TEMPERATURE IS HIGH** – If the compressed air supply lines are warm or hot due to compressed air being heated by running in hot areas like furnaces, in direct sunlight or across ceilings, then the unit will not refrigerate as well. Seek out alternative air supply.
2. **INLET PRESSURE LOW** - restrictions in the air supply line from restrictive fittings, small air lines, etc. will create excessive pressure drop and lower performance. Remove restrictions and increase air line size to correct.
3. **INLET TEMPERATURE NORMAL AND LINE PRESSURE NORMAL BUT OUTPUT POOR** – Excessive back pressure at the cold outlet will reduce performance. Always use either the hose kit supplied or equivalent and keep a minimum ¼" ID in any hose used to minimize back pressure. Sometimes the cold outlet will freeze if water is in the system. That can be corrected by turning off the unit to thaw. To prevent freezing again, add a dryer to the compressed air supply line.

Maintenance is normally not required if the unit is properly filtered but if cleaning is necessary it can be easily dismantled, cleaned and re-assembled.

NEX FLOW

Leading Technology Into The Future

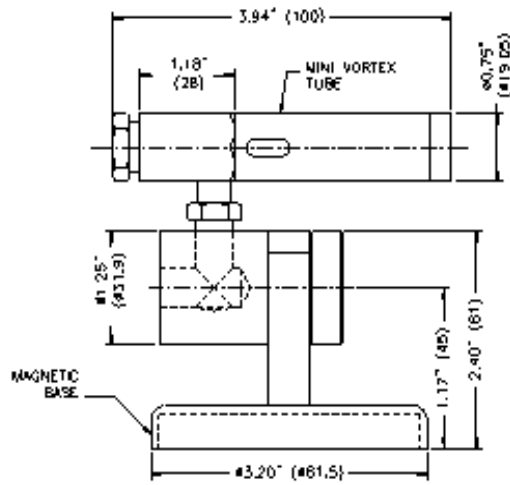

FRONT VIEW

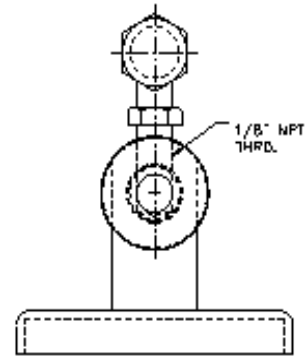

SIDE VIEW

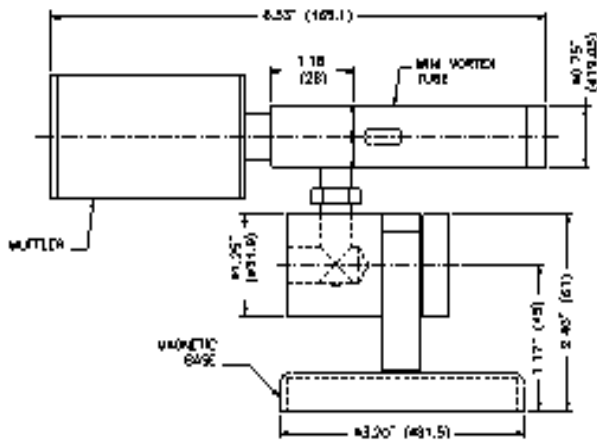

FRONT VIEW

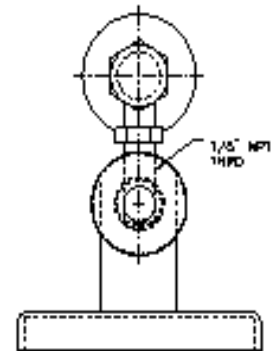

SIDE VIEW

USA & CANADA
Tel.: (877) 797-2777
Fax: (877) 797-2660

INTERNATIONAL
Tel.: (416) 410-1313
Fax: (416) 410-1806

INTERNET
www.nex-flow.com
sales@nex-flow.com