

VX-3A *Fluid* ROWER

Exploded Diagram

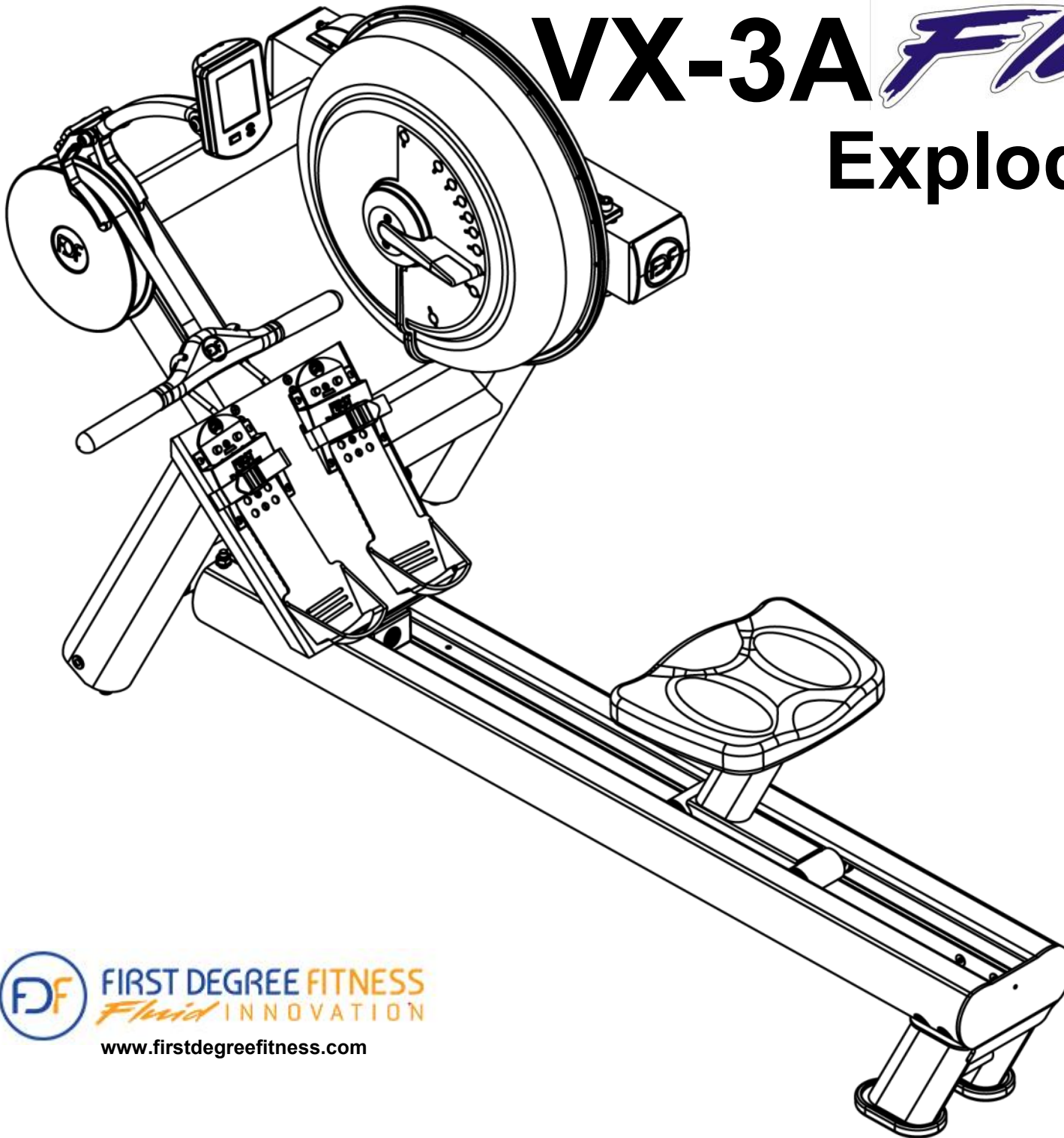

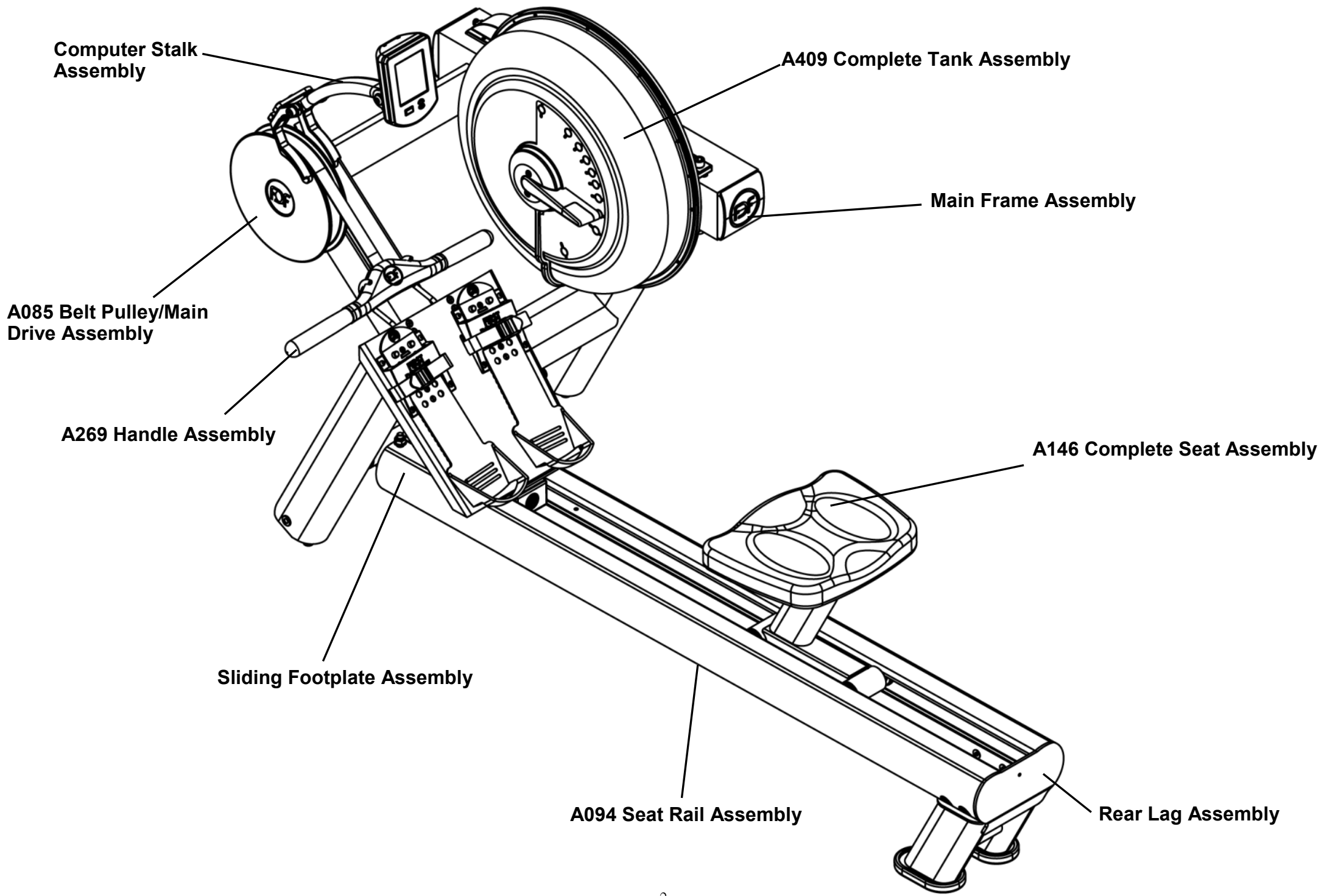

**Computer Stalk
Assembly**

A409 Complete Tank Assembly

Main Frame Assembly

**A085 Belt Pulley/Main
Drive Assembly**

A269 Handle Assembly

A146 Complete Seat Assembly

Sliding Footplate Assembly

A094 Seat Rail Assembly

Rear Lag Assembly

Main Frame Assembly

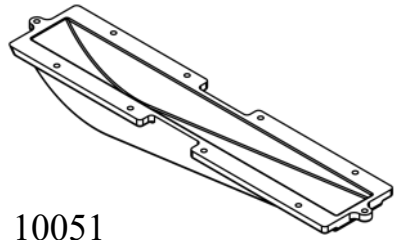

10051
After S/N 14 01061 06

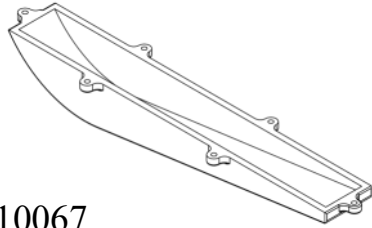

10067
Before S/N 14 02247 05

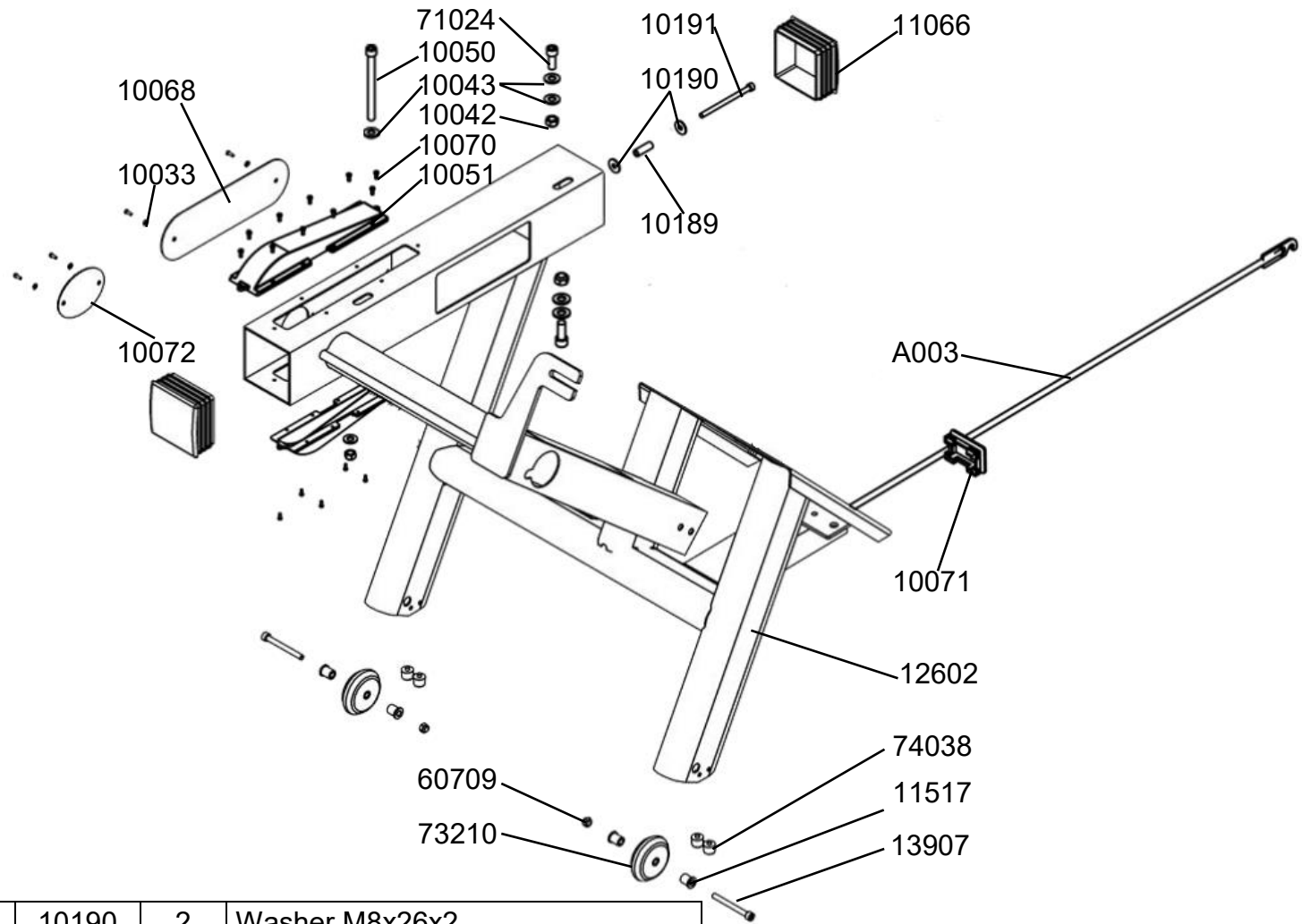

10033	4	Washer 10x4.2x1 SUS	10190	2	Washer M8x26x2
10042	3	Nyloc Nut M12	10191	1	Hex Head Bolt M8x120
10043	6	Washer M13x24x2t	11066	2	End Cap 100x100mm
10050	1	Hex Head Bolt M12x150	11517	4	Spacer for VX-3 Transport Wheel
10051	2	Rubber Cover for Large PK Pulley	12602	1	Main Frame - VX-3A
10068	1	Large Steel Side Cover 276mm	13907	2	Hex Head Bolt M8x75
10070	24	Round Head Phillips Screw M4x10	60709	2	Nyloc Nut M8
10071	1	End Cap Rubber 75x50mm	71024	2	Hex Head Bolt M12x35
10072	1	Small Steel Side Cover 100mm	73210	2	Transport Wheel
10189	1	Tank Tension Adjustment Bushing	74038	4	Rubber Bumper

A003 Bungee Assembly

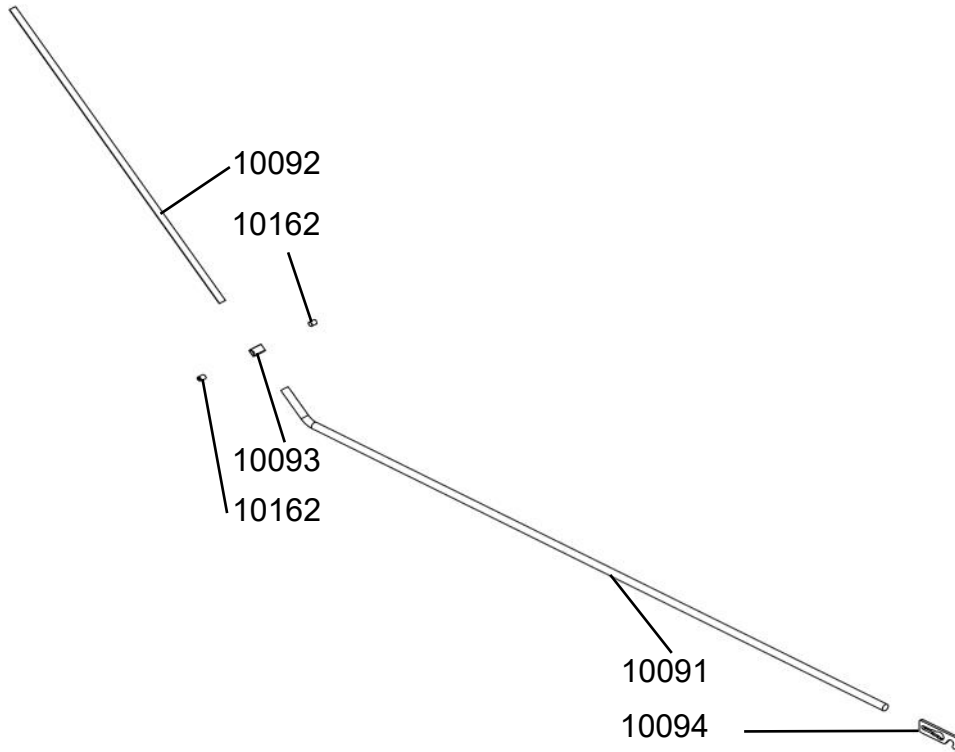

Note to Distributor/Retailer: The parts listed here are not sold separately.

10091	1	Bungee 10mm
10092	1	Belt
10093	1	Shock Cord Joiner
10094	1	Bungee End Hook
10162	2	Grub Screw M8x10

Sliding Footplate Assembly

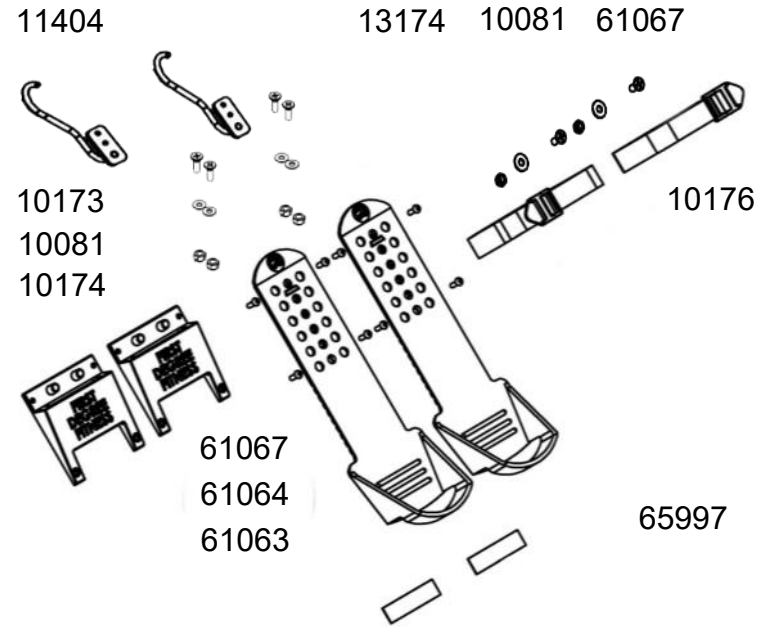

10081	6	Washer M6x16x1
10173	4	Counter Sunk Bolt M6x15
10174	4	Nyloc Nut M6
10176	2	Foot Strap & Buckle
11405	1	Bar Catch - Left
11406	1	Bar Catch - Right
13174	2	Nyloc Nut M5
61063	2	Footplate Slider with Velcro #65997
61064	2	Footplate Slider Base 120x111x22.8
61067	10	Dome Head Bolt M5x15
65997	2	Velcro for Sliding Footplate

Computer Stalk Assembly

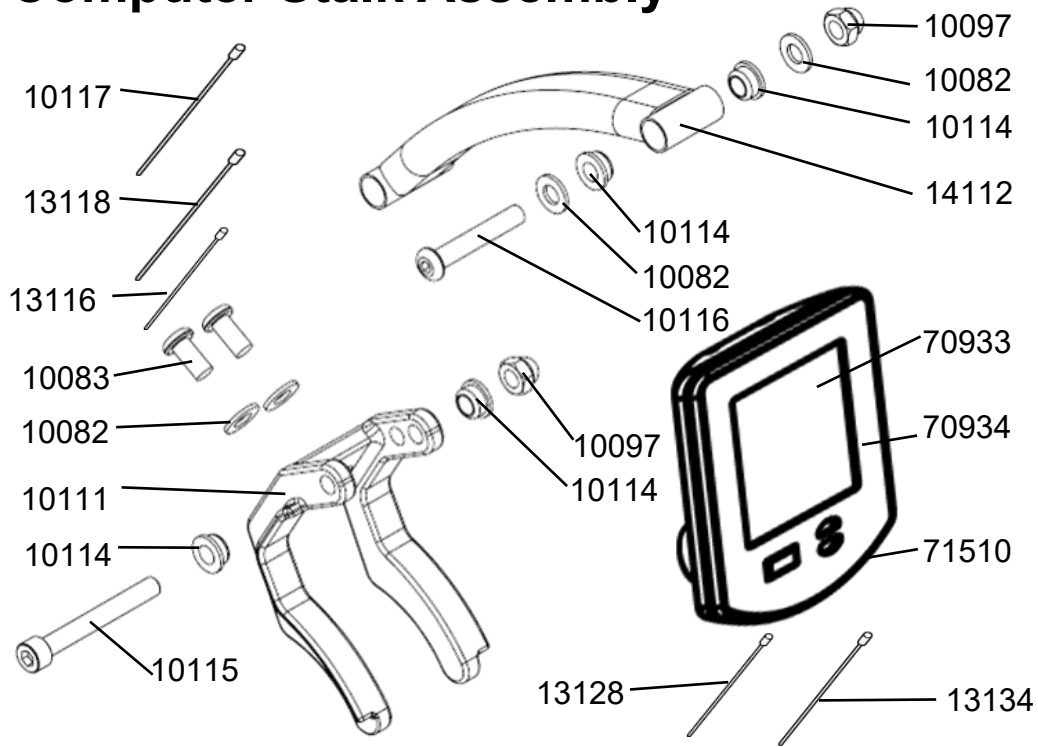

10082	4	Washer M10x21x2
10083	2	Dome Head Bolt M10x20
10097	2	Nut Dome Head M10
10111	1	Belt Guard Aluminum
10114	4	Plastic Bushing 20x16x13x10
10115	1	Hex Head Bolt M10x80
10116	1	Dome Head Bolt M10x60
10117	1	Sensor Wiring 1200mm
13116	1	Sensor Wiring 600mm
13118	1	Heart Rate Wiring 1150mm-Upper
13128	1	Level Wiring 1200mm
13134	1	Computer Wiring 600mm
14112	1	Computer Mounting Arm
70933	1	LCD for Bluetooth Auto-Adjust Monitor
70934	1	Mambrane for 5L/10L/316A/520A
71510	1	Bluetooth Auto-Adjust Monitor

A269 Plastic Handle Complete - E520/VX3

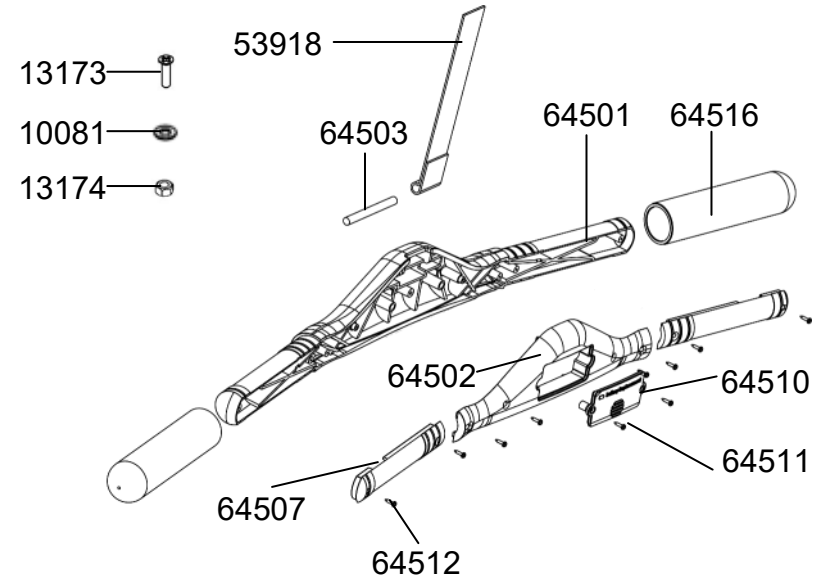

10081	1	Washer M6x16x1
13173	1	Counter Sunk Bolt M5x25
13174	1	Nyloc Nut M5
53918	1	Handle Belt 2000mm- Belt
64501	1	Handle with Decal #64517
64502	1	Handle Plastic Cap
64503	1	Belt Bush
64507	2	Handle Plastic Cap - L/R
64510	1	Battery Cap
64511	2	Round Head Phillips Screw M3x12 SUS - B
64512	10	Counter Sunk Screw for Wood M2x10
64516	2	Handle Grip
64524	1	Plastic Handle Belt 2000mm - HS

A146 Complete Seat Assembly VX-2/VX-3

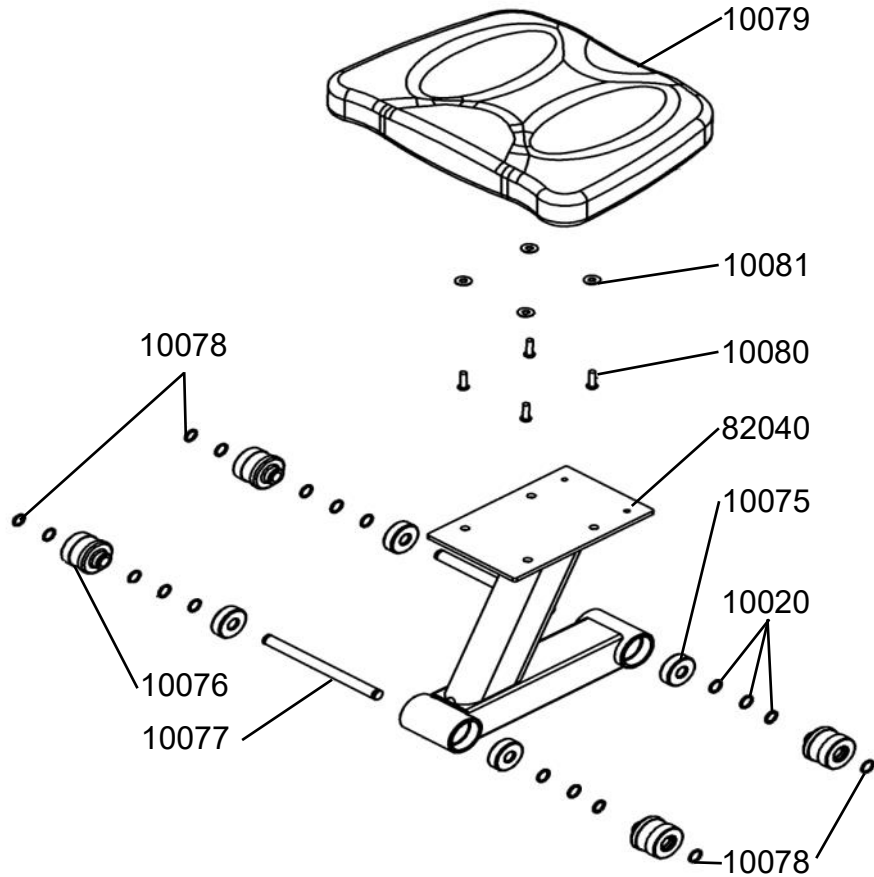

10020	14	Seat Spacer 1x12.5x16
10075	4	Bearing NBN 6301ZZ for Seat Frame
10076	4	Seat Wheel Polyurethane
10077	2	Axle Shaft 12x149
10078	4	C Clip ISTW-12
10079	1	Seat LS-E28
10080	4	Dome Head Bolt M6x20
10081	4	Washer M6x16x1
82040	1	Seat Frame VX2/VX3

A001 Seat Wheel Kit VX-2/VX-3

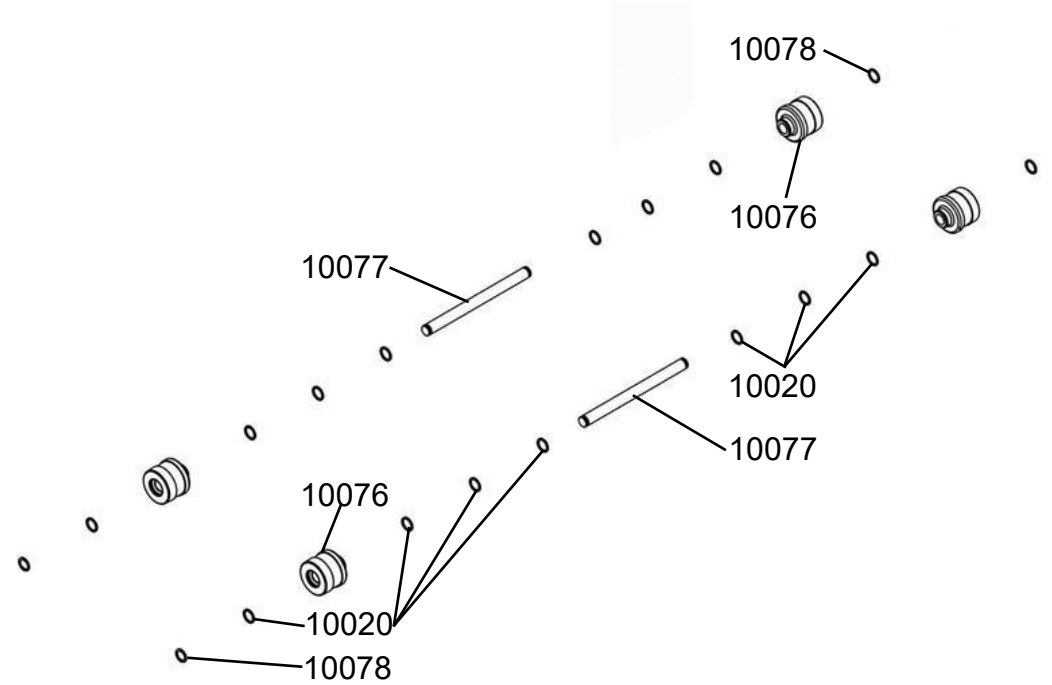

10020	14	Seat Spacer 1x12.5x16
10076	4	Seat Wheel
10077	2	Axle Shaft 12x149
10078	4	C Clip ISTW-12

A085 Belt Pulley/Main Drive Assembly E520/VX3

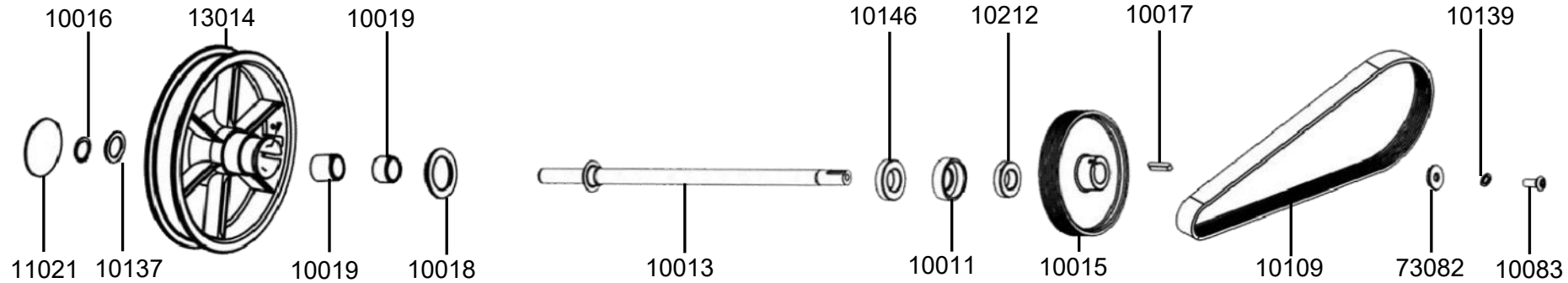

10011	1	Bearing Housing on Pulley Shaft with Bearing #10212
10013	1	Main Pulley Shaft & Shaft Sleeve Bearing Mount
10015	1	Large PK Transmission Pulley 150mm
10016	1	C Clip STW-25
10017	1	Key Way 7x7x32
10018	1	Nylon Pulley Spacer 60x40x6.5
10083	1	Dome Head Bolt M10x20

10109	1	PK Belt 7 Rib 926mm Hutchinson
10137	1	Belt Pulley Spacer 38.1x25.7x2t
10139	1	Spring Washer M10
10146	1	Ball Bearing NSK6006ZZ
11021	1	Decal - Belt Pulley
13014	1	Belt Pulley & 2 x INA One Way Bearings #10019
73082	1	Washer 30x10.2x3t SUS

A002 ABS Belt Pulley Assembly E520/VX3

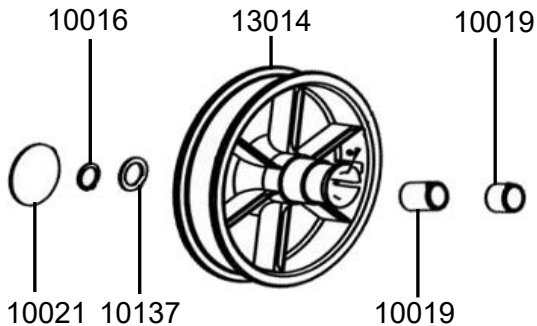

10016	1	C Clip STW-25
10137	1	Belt Pulley Spacer 38.1x25.7x2t
11021	1	Decal - Belt Pulley
13014	1	Belt Pulley & 2 x INA One Way Bearings #10019

A017 Main Pulley Shaft Kit

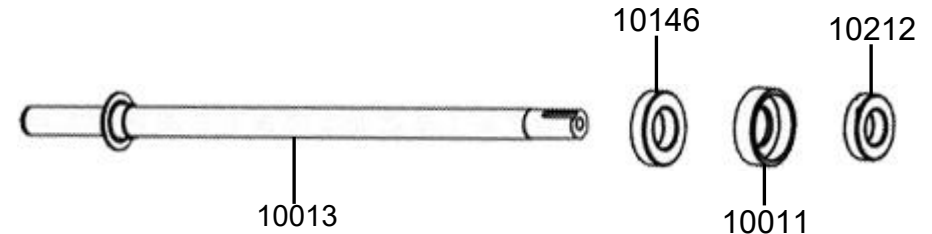

10011	1	Bearing Housing on Pulley Shaft
10013	1	Main Pulley Shaft & Shaft Sleeve Bearing Mount
10146	1	Ball Bearing NSK6006ZZ
10212	1	Bearing FAG6005ZZ

A409 Complete Tank Assembly

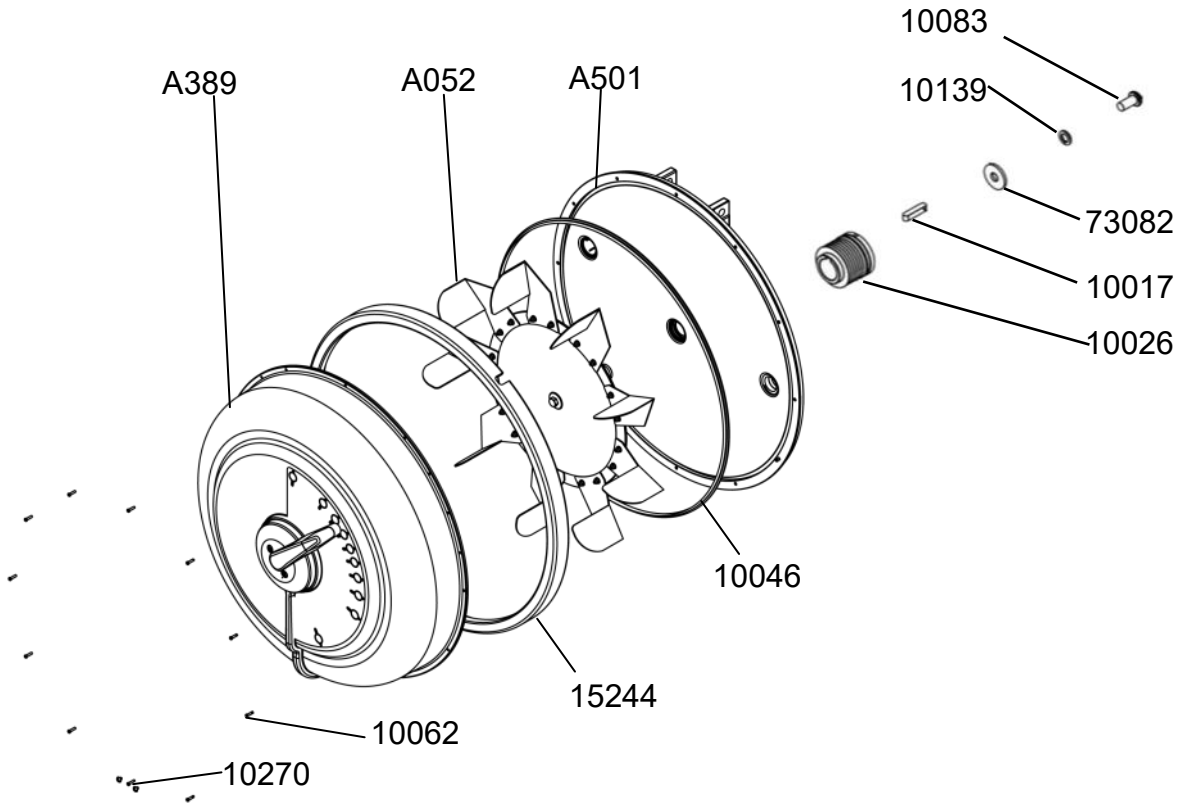

A052	1	Flywheel Assembly
A501	1	Tank Back Kit - Black
A689	1	Tank Cover Assembly
10017	1	Key Way 7x7x32
10026	1	Small 5PK Transmission Pulley 50mm
10046	1	Tank Large Seal
10062	12	Round Head Phillips Screw M3x12 SUS
10083	1	Dome Head Bolt M10x20
10139	1	Spring Washer M10
10270	2	Round Head Phillips Screw M4x8 SUS
15244	1	Tank Outer Cover Ring - Black
73082	1	Washer 30*10.2*3t SUS

A006 Sensor Kit

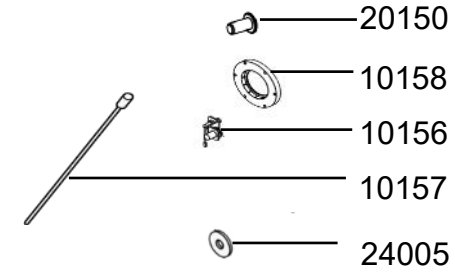

10156	1	Sensor mounting bracket
10157	1	Speed Sensor 300mm
10158	1	Magnetic Ring & 6x Rare Earth Magnet 4mm #10057
20150	1	M10x15 sensor bracket bolt
24005	1	Washer M11x22x1t SUS

A052 Flywheel Assembly E520/VX3

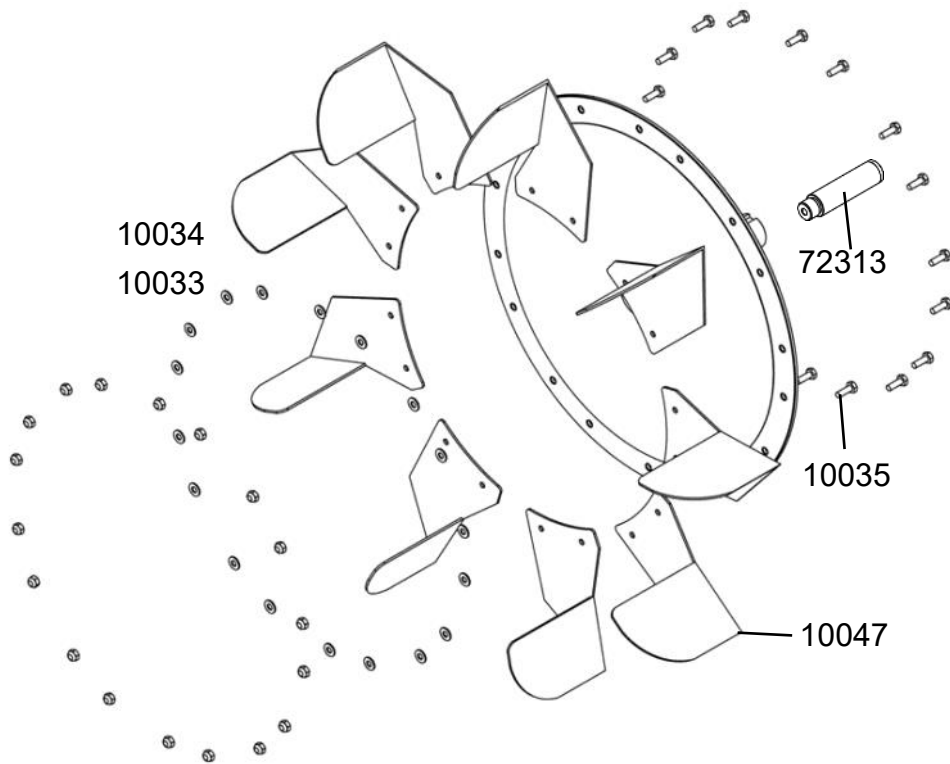

10033	18	Washer 10x4.2x1 SUS
10034	18	Nut M4 SUS
10035	18	Hex Bolt M4 SUS
10047	9	Impeller Blade
70303	1	Flywheel E316/VX2/E520/VX3
72313	1	Impeller Shaft E520/VX3

A012 Tank Bearing & Seal Kit

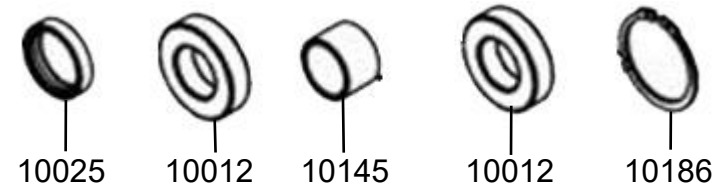

10012	2	Bearing NSK6005ZZ
10025	1	Seal NBR 37x30x8t for Flywheel Shaft
10145	1	Bearing Spacer 30x25.1x20.5mm
10186	1	C Clip RTW-48

A501 Tank Back Kit - Black

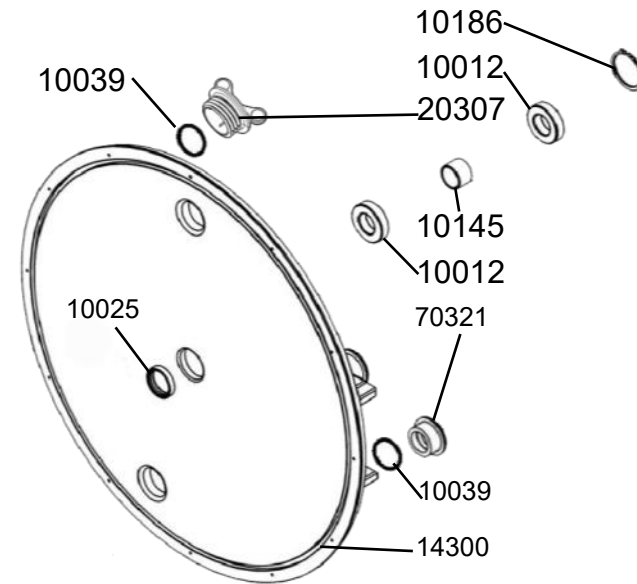

10012	2	Bearing NSK6005ZZ
10025	1	Seal NBR 37x30x8t for Flywheel Shaft
10145	1	Bearing Spacer 30x25.1x20.5mm
10186	1	C Clip RTW-48
14300	1	Tank Back
20307	1	Wing Plug Black with Flat O-Ring #10039
70321	1	Tank Plug Black with O-Ring #10039

A389 Tank Cover Assembly

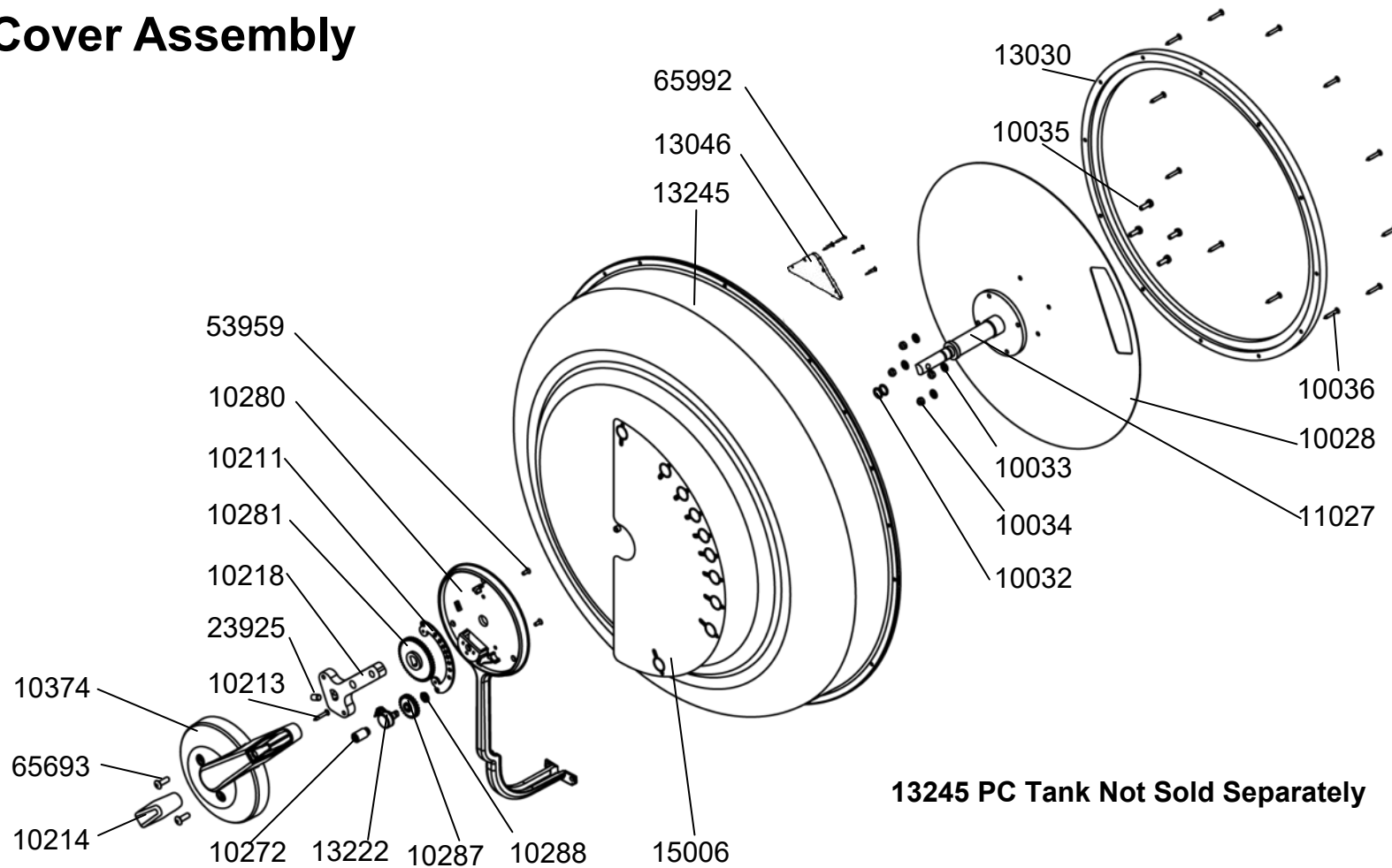

10028	1	Backing Plate 0.8mm SUS	10281	1	Gear M1T48
10032	2	Nylon Resistance Adjuster O Ring 12x9x1.5	10374	1	Adjuster Knob Set Blue incl. Cap #10214 & Screw #10213 & Ball Plunger #10272
10033	4	Washer 10x4.2x1 SUS	11027	1	Adjuster Handle Shaft
10034	4	Nut M4 SUS	13030	1	Adjuster PP Tank Ring 358x10
10035	4	Hex Bolt M4 SUS	13245	1	PC Tank Cover with Decal #15006 & Triangle plate #13046 & Bolts #65992 - Gray
10036	12	Flat Tapping Screw M3x20 SUS	23925	1	Grub Screw M6x10
10211	1	Locating Plate	53959	2	Counter Sunk Bolt M3x8 - SUS
10218	1	Adjuster Handle	65693	2	Dome Head Bolt M5x15 - B
10280	1	Lever Base incl. Potentiometer, #13222 Gear #10287 & Nut #10288			

Seat Rail and Rear Leg Assembly

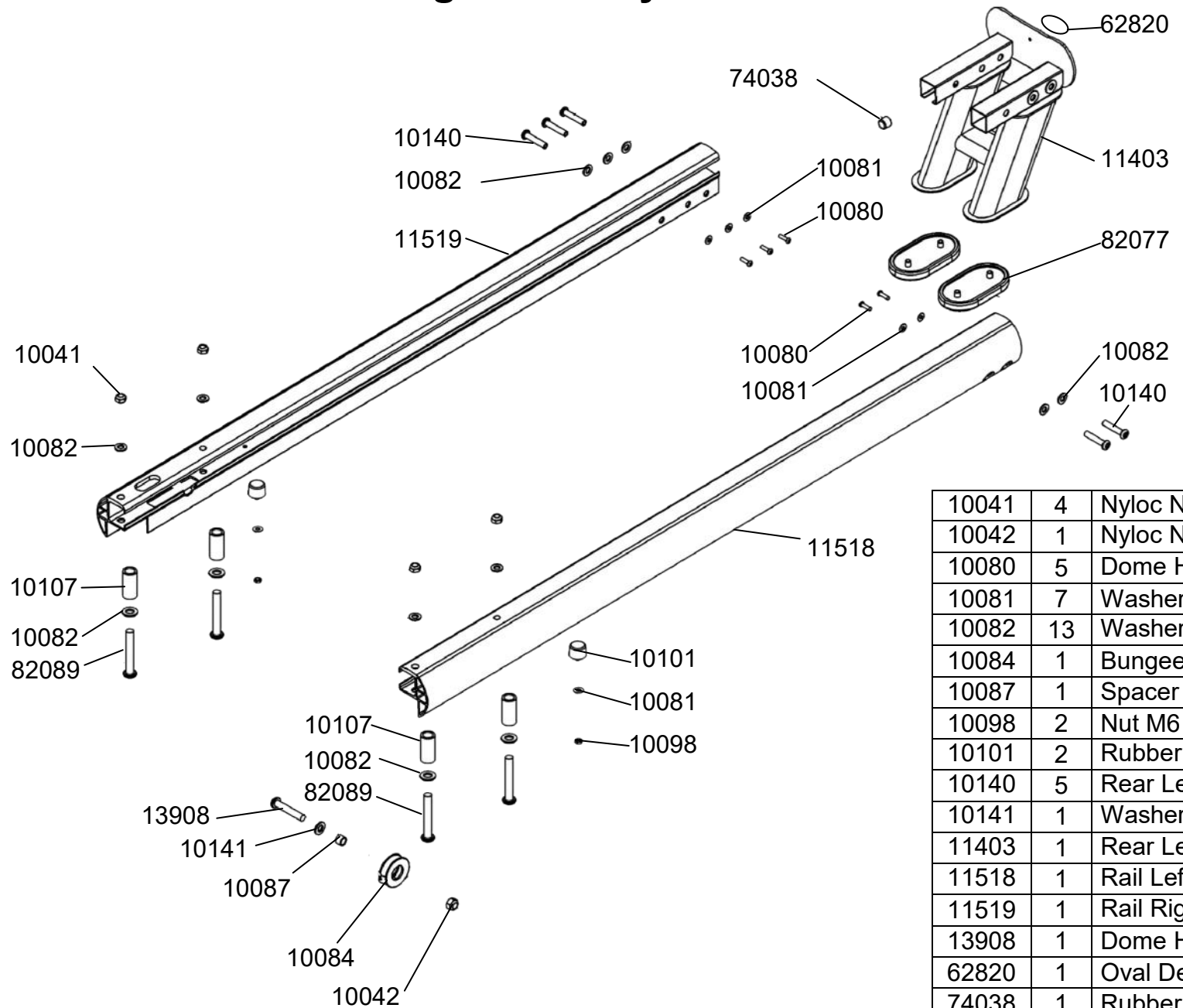

10041	4	Nyloc Nut M10
10042	1	Nyloc Nut M12
10080	5	Dome Head Bolt M6x20
10081	7	Washer M6x16x1
10082	13	Washer M10x21x2
10084	1	Bungee Pulley with Bearing #10085 & Clip #10086
10087	1	Spacer 16x12x12.5
10098	2	Nut M6
10101	2	Rubber Bumper TT500
10140	5	Rear Leg Bolt M10x47.5mm
10141	1	Washer 13x20x1t
11403	1	Rear Leg VX3 with Oval Decal
11518	1	Rail Left - VX3 with Decals
11519	1	Rail Right - VX3 with Decals
13908	1	Dome Head Bolt M12x65
62820	1	Oval Decal - FDF
74038	1	Rubber Bumper
82077	2	Rubber Feet for Rear Leg - VX2/3
82089	4	Dome Head Bolt M10x80

A094 Seat Rail Set Complete - VX-3

Seat Rail—Right Assembly

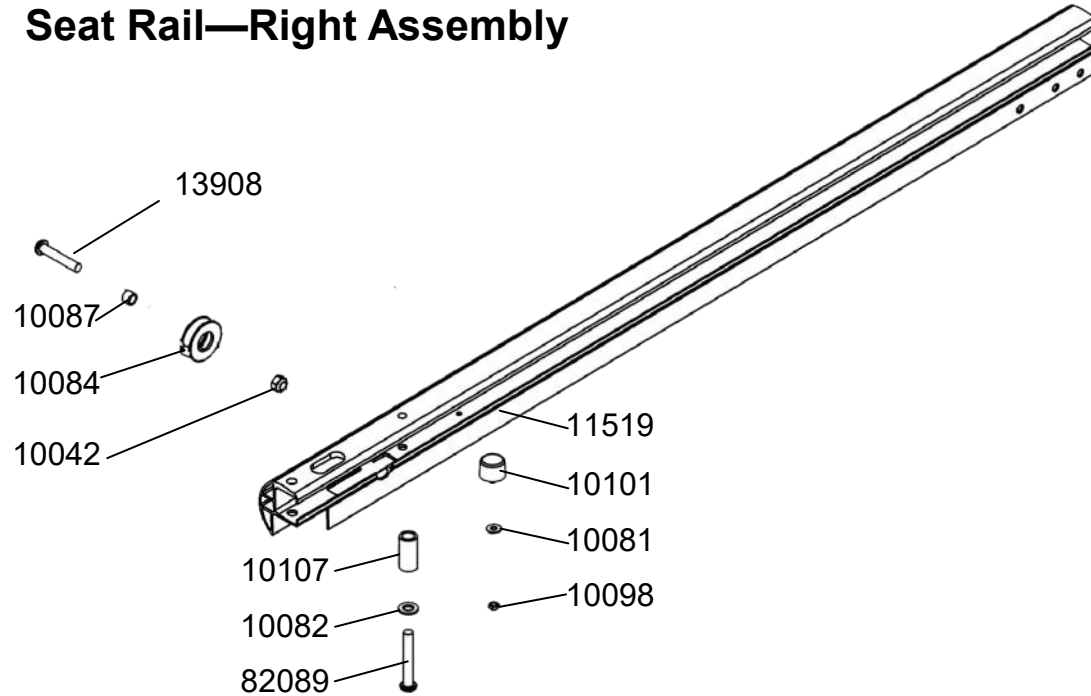

10042	1	Nyloc Nut M12
10081	1	Washer M6x16x1
10082	1	Washer M10x21x2
10084	1	Bungee Pulley with Bearing #10085 & Clip #10086
10087	1	Spacer 16x12x12.5
10098	1	Nut M6
10101	1	Rubber Bumper TT500
10107	1	Spacer for Rail
11519	1	Rail Right with Decals - VX3
13908	1	Dome Head Bolt M12x65
82089	1	Dome Head Bolt M10 x 80

Seat Rail—Left Assembly

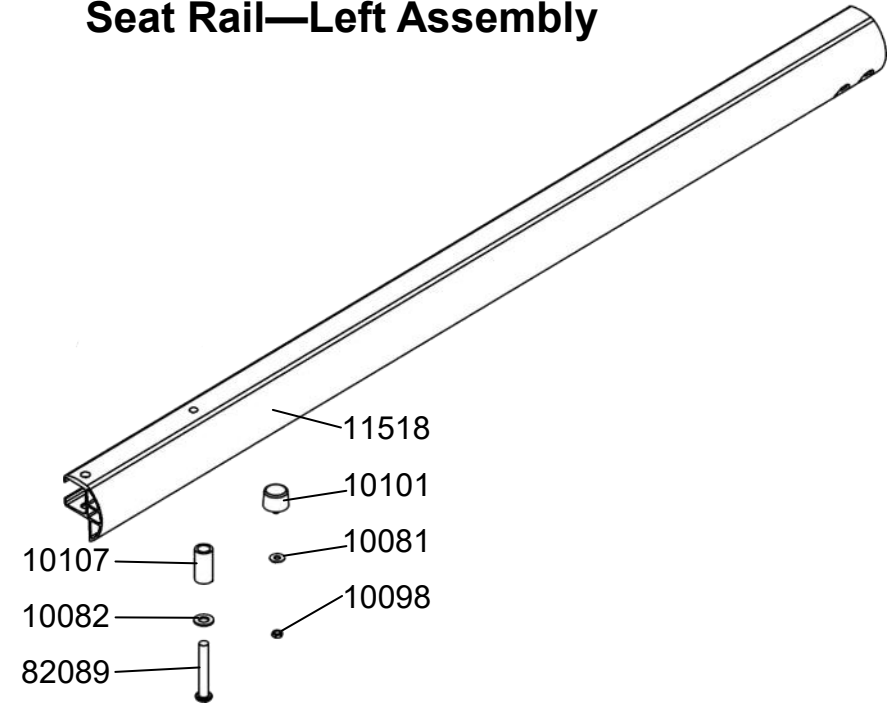

10081	1	Washer M6x16x1
10082	1	Washer M10x21x2
10098	1	Nut M6
10101	1	Rubber Bumper TT500
10107	1	Spacer for Rail
11518	1	Rail Left with Decals - VX3
82089	1	Dome Head Bolt M10 x 80

HVX3A - Hardware Kit

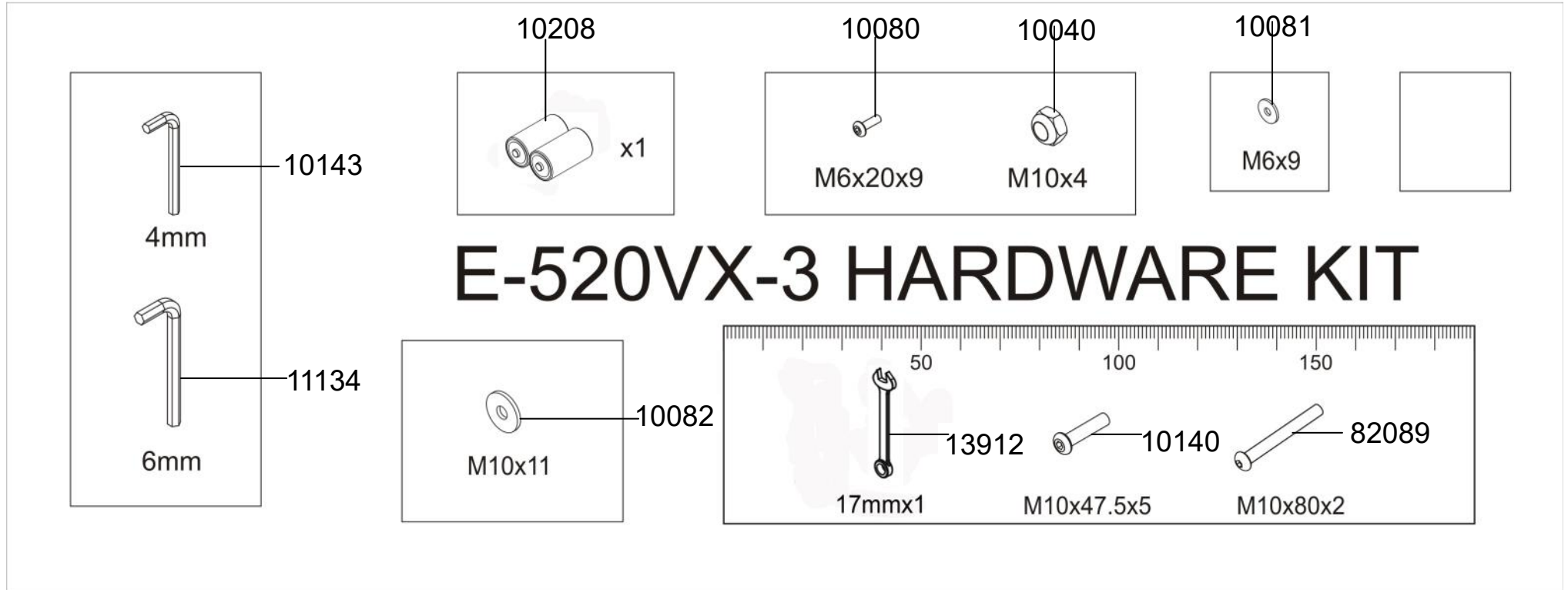

10041	4	Nyloc Nut M10
10080	9	Dome Head Bolt M6x20
10081	9	Washer M6x16x1
10082	11	Washer M10x21x2
10140	5	Rear Leg Bolt M10x47.5mm
10143	1	Allen Key 4mm
10208	1	D Cell Duracell Battery
11134	1	Allen Key 6mm
13912	1	17mm Spanner
82089	2	Dome Head Bolt M10 x 80