

SIPROTEC 7RE2800

Voltage Balance Relay

Instruction manual

Order nr.:E50417-G1176-C130-A1



Contents

1	TECHNICAL DESCRIPTION	3
1.1	APPLICATION.....	3
1.2	GENERAL	3
1.3	DESIGN.....	3
2	CONSTRUCTION.....	4
2.1	TYPE OF CONSTRUCTION AND DIMENSION	4
2.1.1	<i>Voltage balance relay 7RE2800-0BA00 for panel surface mounting.....</i>	<i>4</i>
2.1.2	<i>Voltage balance relay 7RE2800-0CA00 for cubicle or panel flush mounting.....</i>	<i>4</i>
3	ORDERING DATA	5
3.1.1	<i>Ordering data for cubicle flush mounting and panel surface mounting.....</i>	<i>5</i>
4	TECHNICAL DATA	6
4.1	TECHNICAL DATA	6
5	DRAWINGS.....	7
5.1	TERMINAL DIAGRAM.....	7
5.2	CIRCUIT DIAGRAM.....	8
5.3	DIMENSIONS.....	9
5.4	APPLICATIONS.....	10

NOTE

This instruction manual does not purport to cover all details in equipment, nor to provide for every possible contingency to be met in connection with installation, operation or maintenance.

Should further information be desired or should particular problems arise which are not covered sufficiently for the purchaser's purpose, the matter should be referred to the local Siemens sales office.

The contents of this instruction manual shall not become part nor modify any prior or existing agreement, commitment or relationship. The sales contract contains the entire obligations of Siemens. The warranty contained in the contract between the parties is the sole warranty of Siemens. Any statements contained herein do not create new warranties nor modify the existing warranty.

1 Technical Description

1.1 Application

In many countries the short circuit protection for potential transformers is made by 3 single pole fuses and not with 3-pole-MCB's.

If exists a potential transformer with two secondary windings or two independent sets of potential transformers there is the possibility to detect a blown fuse quickly and easily by compare the two secondary voltages.

The condition for correct function is the connection to two similar sets of potential transformers at the same busbar.

The relay should act as quick as possible to inhibit the undesired operation e.g. of distance relays or voltage regulators.

1.2 General

- Failure indication of single-, two- or three phase voltages
- LED indication of the involved phases
- Fix operate value
- No auxiliary power supply needed
- Operating time lower than 18 ms

1.3 Design

The function „voltage balance“ is built by one potential supervision module 7TU1800-3.

The module contains:

- twice three input transformers for three phase voltages,
- the balanced bridge circuit,
- twice three red LED for phase-failure indication ($3x U_2 < U_1$, $3x U_1 < U_2$) and
- the corresponding trip relays (K7 – K12) with one NO-contact for each.

The measuring circuit is comparing the instantaneous values of two secondary voltages at the same phase angle. Therefore the two sets of potential transformers must have the same vector group and must be connected to the same busbar.

2 Construction

2.1 Type of construction and dimension

2.1.1 Voltage balance relay 7RE2800-0BA00 for panel surface mounting

Connectors	10 terminals (up to 7mm ² / AWG 9) on top and bottom
Housing	7XP2020-1L (see fig. 5.1)
Color	RAL 7032 silica-gray
Degree of protection	IP 51
Weight	app. 5,2 kg

2.1.2 Voltage balance relay 7RE2800-0CA00 for cubicle or panel flush mounting

Connectors	rearsite with: 4 terminal-modules W73077-A1327-U4 (380 V, 10 A cont., terminal up to 1,5mm ² / AWG 15 test-voltage. 2kV, 1min. / imp. 5kV 1/50µs)
Housing	7XP2020-2L (see fig. 5.2)
Color	RAL 7032 silica-gray
Degree of protection	IP 51
Weight	app. 4,7 kg

3 Ordering data

3.1.1 Ordering data for cubicle flush mounting and panel surface mounting

Numerical protection relay												
Numerical protection relay 7RE2800												
Product description:												
Numerical protection relay												
Order-No.:							7	8	9	10	11	12
7 R E 2 8 0 0							-	0		A	0	0
Type of construction								9				
Housing 7XP2020 for surface mounting								B				
Terminals on top/bottom												
Housing 7XP2020 for flush mounting								C				
Terminals rearside												

4 Technical data

4.1 Technical data

Measuring circuits

Rated voltage	100 / 125 V , 50/60 Hz
Allowed voltage variation	80 – 130 V
Burden	2 VA / phase

Operate time

Operate voltage (voltage difference)	18-24 V (phase – starpoint)
Operate time	18 ms (80V / 50Hz allowed voltage) 15 ms (100V / 50Hz rated voltage)
Reset time	app. 40 ms

Contacts

Max. voltage	250 V
Max. current	2 A, continuously
Max. make-brake capacity	2000VA, a.c. 50 W, D.C. (depends on operate voltage) limit curve MSR V23061-..
Dielectric test voltage	in accordance with IEC 255-5, EN 60255-6 (2kV, 50Hz, 1min.)

5 Drawings

5.1 Terminal diagram

Terminal disposition at housing

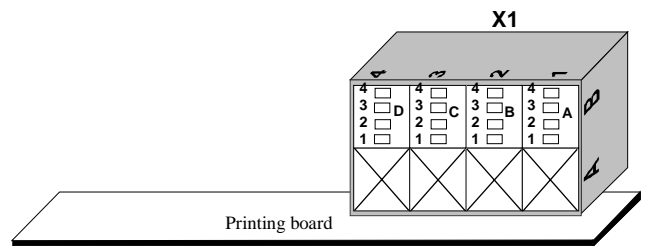
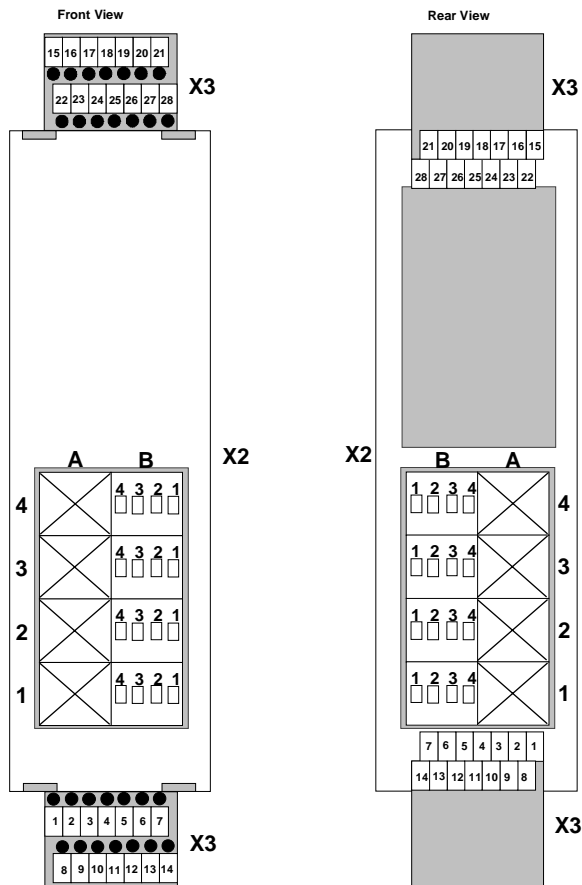

- X1: Modul-plug on printing board
- X2: Modul-plug on rearside (for flush mounting)
- X3: Terminals on top/bottom (necessary for surface mounting)

5.2 Circuit diagram

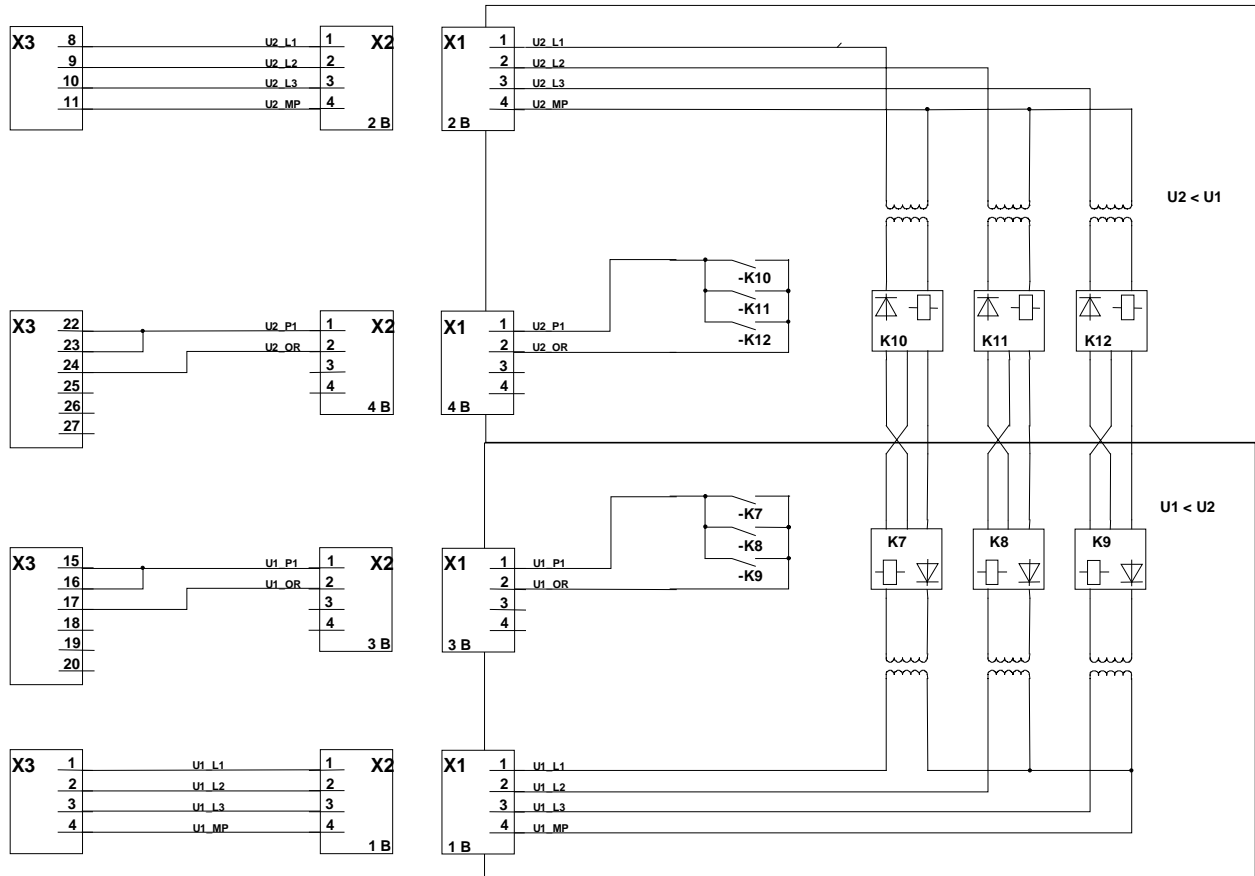

Terminal designation
 1 B 1
 (Modul-line; modul-column; terminal number)

- X1: Modul-plug on printing board
- X2: Modul-plug on rearside (for flush mounting)
- X3: Terminals on top/bottom (necessary for surface mounting)

5.3 Dimensions

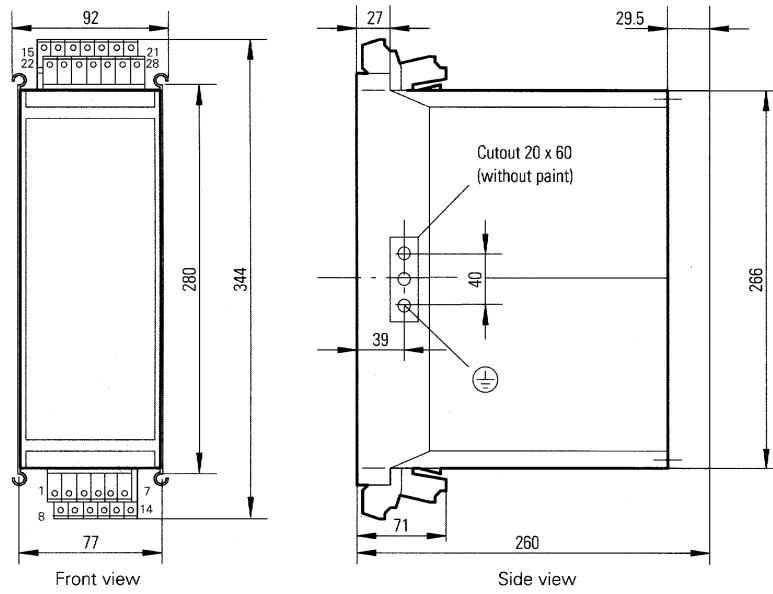

Fig. 5.3.1 Housing 7XP2020-1 (for panel surface mounting)

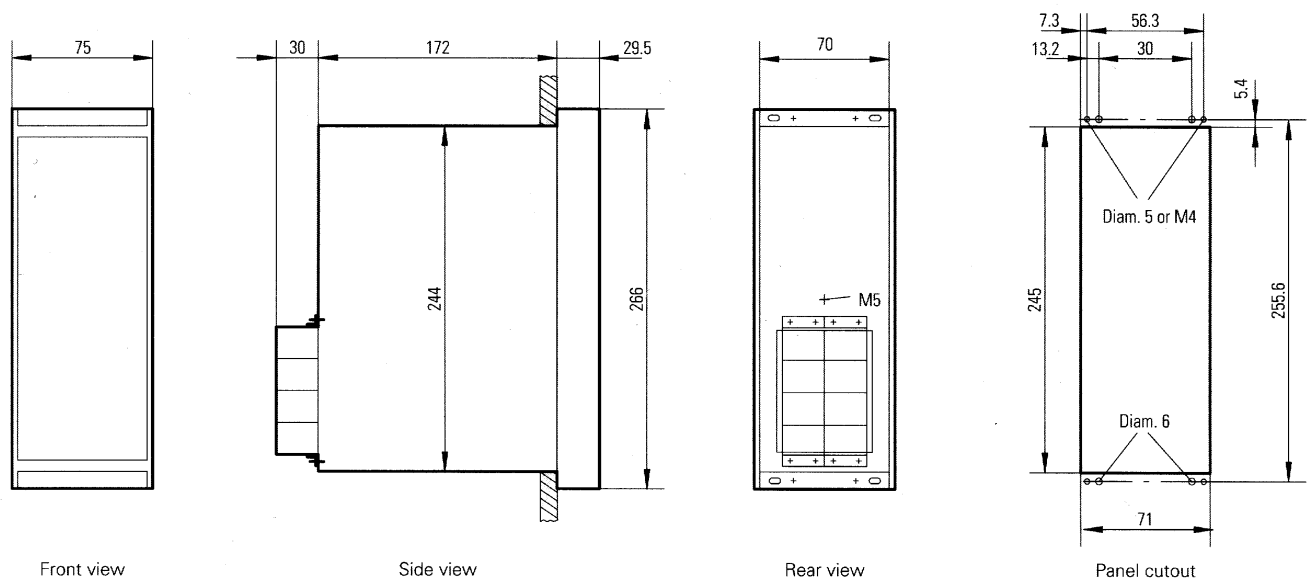

Fig. 5.3.2 Housing 7XP2020-2 (for panel or cubicle flush mounting)

5.4 Applications

Wiring of protection relay should be made in accordance to enclosed circuit diagram.

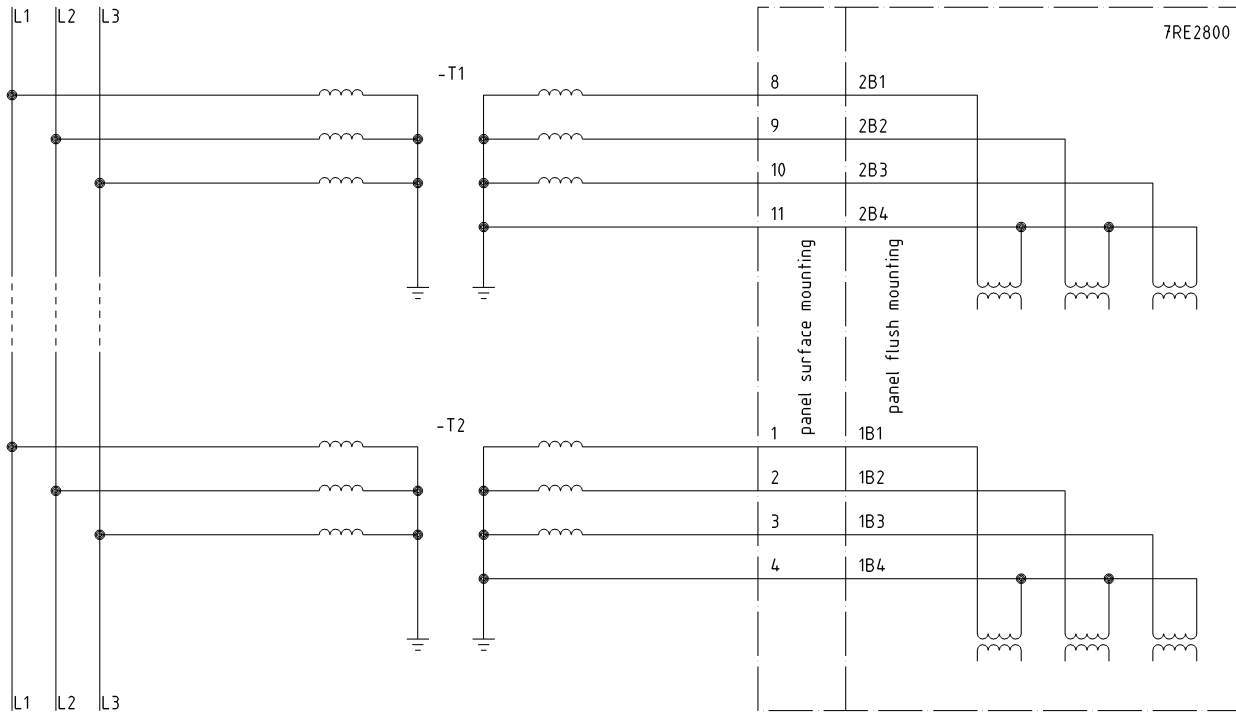

Fig. 5.4.1 Wiring on 3-phase potential transformers

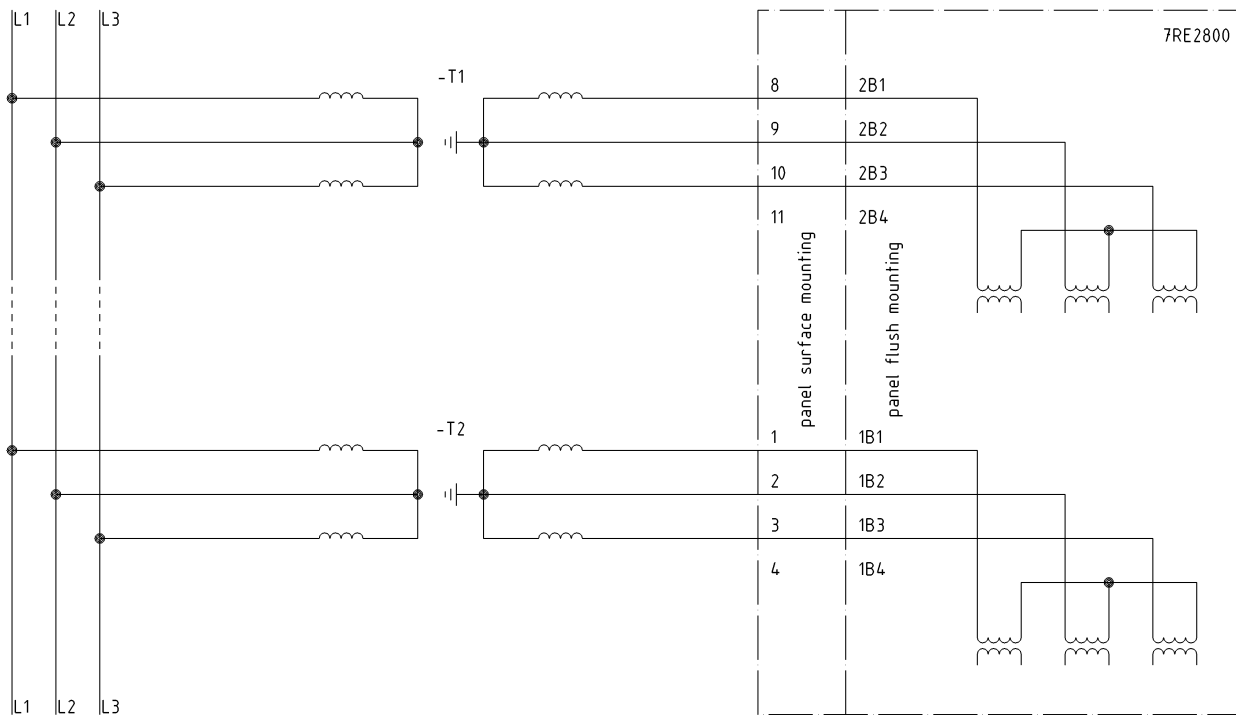

Fig. 5.4.2 Wiring on V-connection potential transformers