

科技創新 引領未來  
science and technological  
innovation lead the future

2020

**Evermore**<sup>®</sup>  
=precision series=  
www.evermore-tools.com

Evermore<sup>®</sup>

勤堃機械股份有限公司 EVERMORE MACHINE CO.,LTD.

# PSC系列刀具

PSC Tool Holder Series

- PSC刀柄
- PSC刀座

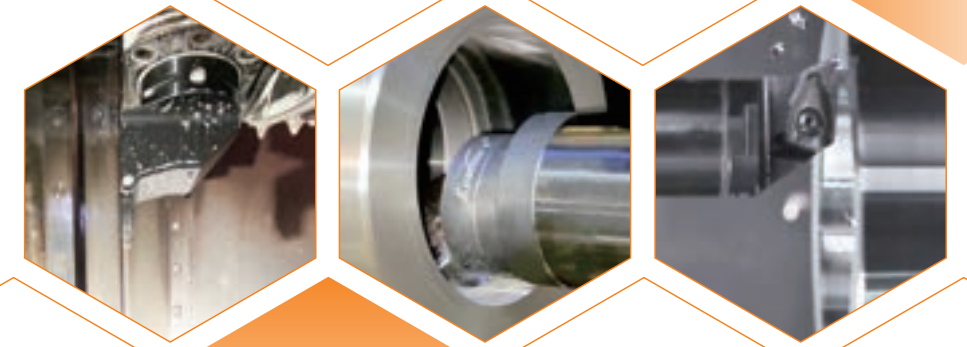

**Evermore**<sup>®</sup>  
=precision series=

**勤堃機械股份有限公司**  
EVERMORE MACHINE CO.,LTD.

台中市霧峰區四德里北豐路33號  
No. 33, Pei Fong Rd., Shin Ten Borough,  
Wu Feng Dist., Taichung City, Taiwan 413  
TEL: +886-4-23398694 23323135  
FAX: +886-4-23339230  
E-mail: info@evermore-tools.com  
http://www.evermore-tools.com



**勤堃機械股份有限公司**  
EVERMORE MACHINE CO.,LTD.

2020

# 科技創新 引領未來

science and technological  
innovation lead the future



## >>> COMPANY INTRODUCTION | 公司簡介

自1979年創立以來，致力於專業生產KEYLESS DRILL CHUCK，高精度自緊式鑽夾頭，並創立了自有品牌“EVERMORE”。

無論在品質維護、技術研發、產能穩定等各方面，多年來始終維持不斷精進的腳步；1992年，成立VDI部門，生產各種車銑複合車床VDI動力刀座和固定刀座；2002年，開始生產CNC刀杆，精鏜粗鏜刀杆，HSK刀杆等精密機械配件；2008年，延續勤堊成功的經驗，開始研發，生產氣動夾爪。無論在品質管理上或是客戶服務都達到一定水準。

本公司最重視的是“品質”及“服務”。在嚴格的品管制度下，所有出廠產品皆採用最精密的“測量儀器”檢驗，希望在未來的機械配件的領域有更高品質展現，提供更精密準確、高速化、復合化產品來滿足客戶的需求、降低客戶的成本、提高效率。

本公司長遠的目標，將所生產產品達到先驅，讓客戶藉由使用我們的產品而改變以往的加工方式，進而提升精度、改善良率、發揮效率，這就是敝公司為本的方針。

Established in 1979 specializing in the manufacture of Keyless Drill Chucks under the brand names Evermore and Golden Goose. The company is always pushing ahead and improving business operations, product quality, developing new technology, and stabilizing production capacity. In 1992 the company set up its VDI department producing VDI turning/milling tool holders, and in 2002 successfully began producing CNC chucks, Boring tooling system, tool holders and other precision machine accessories. In 2008, the company started research and development, production pneumatic grippers. Whether in terms of quality management or customer service has reached the certain level.

Evermore is a trusted supplier to big names in the machine tool industry around the world.

Quality and service are valued most in our company.

























Products are rigorously tested throughout. Every area has its own QC lab and products are put through scheduled and random inspections. Finished products are 100% inspected guaranteeing quality, timeliness, and customer specifications. Provide more precision and accuracy, high-speed, modular products to meet the customer demand, reduce customer costs and improve effective.

Vanguard products are the long-term objective of our company

Most importantly, Evermore will keep improving product precision and production efficiency. It is Evermore's sincere wish to work with customers to create a better industry with unlimited services and innovations!

EVERMORE EVERMORE

## PSC 內孔刀具 PSC One-Piece Boring Bar Holder

<p>PCLNR/L-HP</p>  <p>07</p>	<p>DCLNR/L</p>  <p>08</p>	<p>PCLNR/L-M1</p>  <p>09</p>	<p>PDUNR/L-HP</p>  <p>10</p>
<p>DDUNR/L</p>  <p>11</p>	<p>PDUNR/L-M1</p>  <p>12</p>	<p>PSKNR/L-HP</p>  <p>13</p>	<p>PSKNR/L-M1</p>  <p>14</p>
<p>DTFNR/L</p>  <p>15</p>	<p>PTFNR/L-W</p>  <p>16</p>	<p>MVUNR/L</p>  <p>17</p>	<p>PWLNR/L-HP</p>  <p>18</p>
<p>DWLNR/L</p>  <p>19</p>	<p>MWLNR/L</p>  <p>20</p>	<p>SCLCR/L-HP</p>  <p>21</p>	<p>SCLCR/L</p>  <p>22</p>
<p>SDUCR/L-HP</p>  <p>23</p>	<p>SDUCR/L</p>  <p>24</p>	<p>SSKCR</p>  <p>25</p>	<p>STFCR/L-HPB</p>  <p>26</p>
<p>STFCR/L-B</p>  <p>27</p>	<p>SVQBR/L-HP</p>  <p>28</p>	<p>SVQBR/L-B</p>  <p>29</p>	<p>SDUCR/L-X</p>  <p>30</p>
<p>SNR/L</p>  <p>31</p>			

## PSC 外徑刀具 PSC One-Piece Turning Holder

<p>PCLNR/L-HP</p>  <p>32</p>	<p>DCMNN</p>  <p>33</p>	<p>DCLNR/L</p>  <p>34</p>	<p>DCRNR/L</p>  <p>35</p>
<p>DCKNR/L</p>  <p>36</p>	<p>PCLNR/L</p>  <p>37</p>	<p>PDJNR/L-HP</p>  <p>38</p>	<p>DDMNR/L</p>  <p>39</p>

## PSC 外徑刀具 PSC One-Piece Turning Holder

<p><b>DDJNR/L</b></p>  <p>40</p>	<p><b>DDNNN</b></p>  <p>41</p>	<p><b>DDUNR/L</b></p>  <p>42</p>	<p><b>PDJNR/L</b></p>  <p>43</p>
<p><b>DRSNR/L</b></p>  <p>44</p>	<p><b>PRSCR/L</b></p>  <p>45</p>	<p><b>PSSNR/L-HP</b></p>  <p>46</p>	<p><b>DSDNN</b></p>  <p>47</p>
<p><b>DSRNR/L</b></p>  <p>48</p>	<p><b>DSSNR/L</b></p>  <p>49</p>	<p><b>PSKNR/L</b></p>  <p>50</p>	<p><b>PSRNR/L</b></p>  <p>51</p>
<p><b>PSSNR/L</b></p>  <p>52</p>	<p><b>PSDNN</b></p>  <p>53</p>	<p><b>DTGNR/L</b></p>  <p>54</p>	<p><b>DTTNR/L</b></p>  <p>55</p>
<p><b>MTJNR/L</b></p>  <p>56</p>	<p><b>DVJNR/L</b></p>  <p>57</p>	<p><b>MVJNR/L</b></p>  <p>58</p>	<p><b>DWLNR/L</b></p>  <p>59</p>
<p><b>MWLNR/L</b></p>  <p>60</p>	<p><b>SCLCR/L-HPA</b></p>  <p>61</p>	<p><b>SCLCR/L</b></p>  <p>62</p>	<p><b>SCMCN</b></p>  <p>63</p>
<p><b>SDJCR/L-HPA</b></p>  <p>64</p>	<p><b>SDNCN</b></p>  <p>65</p>	<p><b>SRSCR/L-HP</b></p>  <p>66</p>	<p><b>SRDCN-HPA</b></p>  <p>67</p>
<p><b>SRSCR/L-HPA</b></p>  <p>68</p>	<p><b>SRDCN</b></p>  <p>69</p>	<p><b>SRDCN-A</b></p>  <p>70</p>	<p><b>SRSCR/L</b></p>  <p>71</p>
<p><b>STJCR/L</b></p>  <p>72</p>	<p><b>SVJBR/L-HP</b></p>  <p>73</p>	<p><b>SVHBR/L-HPA</b></p>  <p>74</p>	<p><b>SVJBR/L-HPAB</b></p>  <p>75</p>
<p><b>SVHBR/L</b></p>  <p>76</p>	<p><b>SVVBN</b></p>  <p>77</p>	<p><b>SVMBL</b></p>  <p>78</p>	<p><b>SVSBR/L-HPA</b></p>  <p>79</p>

## PSC 外徑刀具 PSC One-Piece Turning Holder

R/LFA-E



80

SER/L



81

## PSC 刀座系列 PSC Tool Holder Series

BMT刀塔 - PSC 模組化固定刀座

BMT - PSC Static Tool Holder

82

BMT刀塔 - PSC 模組化動力刀座

BMT - PSC Driven Tool Holder

88

MAZAK 機床 - PSC 模組化固定刀座

MAZAK - PSC Static Tool Holder

90

MAZAK 機床 - PSC 模組化動力刀座

MAZAK - PSC Driven Tool Holder

94

Mori Seiki 機床 - PSC 模組化固定刀座

Mori Seiki - PSC Static Tool Holder

96

Mori Seiki 機床 - PSC 模組化動力刀座

Mori Seiki - PSC Driven Tool Holder

100

Nakamura Tome 機床 - PSC 模組化固定刀座

Nakamura Tome - PSC Static Tool Holder

102

Nakamura Tome 機床 - PSC 模組化動力刀座

Nakamura Tome - PSC Driven Tool Holder

105

Okuma 機床 - PSC 模組化固定刀座

Okuma - PSC Static Tool Holder

107

Okuma 機床 - PSC 模組化動力刀座

Okuma - PSC Driven Tool Holder

112

非特定機床的 PSC 模組化固定刀座

Non-specific Machine Type - PSC Static Tool Holder

114



● 針對外圓車削而優化  
Optimization of external turning

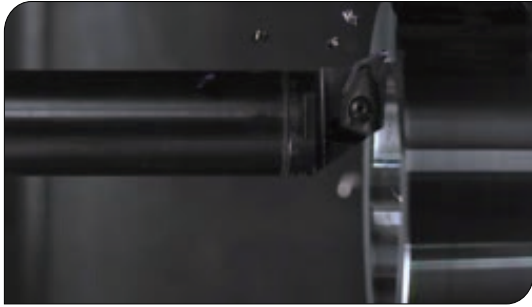

● 渦殼加工解決方案  
Solution for Volute Machining



- 內徑車削  
ID turning
- 外徑與端面車削  
OD and face turning
- 非標定制成型車刀  
non-standard customized form tool
- 半精加工到精加工  
from semi-finishing to finish machining

● 用於細長零件外圓和內孔車削  
Used for the external turning and  
internal drilling of long, narrow  
parts



- 縱向車削  
vertical turning
- 端面車削  
face turning
- 背鏜  
boring
- 直徑6mm起的孔的內孔車削  
internal drilling of holes larger than 6mm  
in diameter
- 半精加工到精加工  
from semi-finishing to finish machining

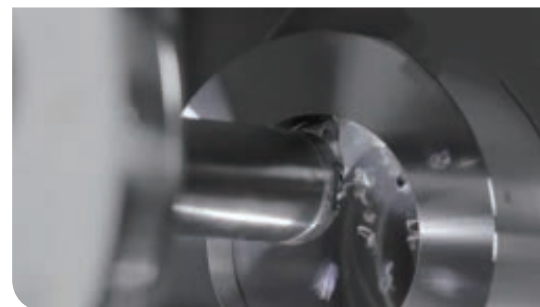







機床夾緊單元的適配件，專為特定的接口設計，能通過縮短裝夾和生產時間而使機床的利用率大為提升。

Adapter for the machine locking unit, custom-designed for specific interfaces. By shortening the clamping and production times, the utilization rate of the machine can be greatly increased.

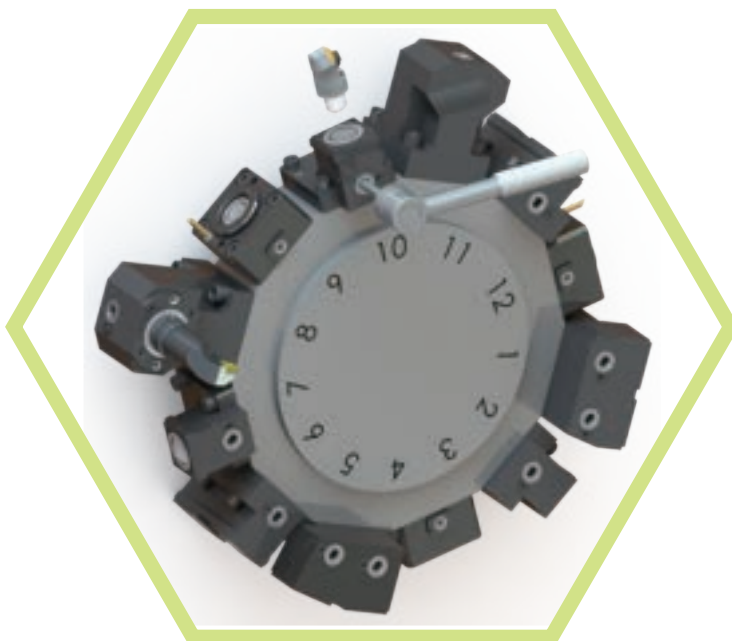

這些夾緊單元與動力刀座專為匹配專用的轉塔接口而設計。

These locking units and power tool holders are custom-designed for specific turret interfaces.

## ● 如何選擇夾緊單元 How to choose clamping unit

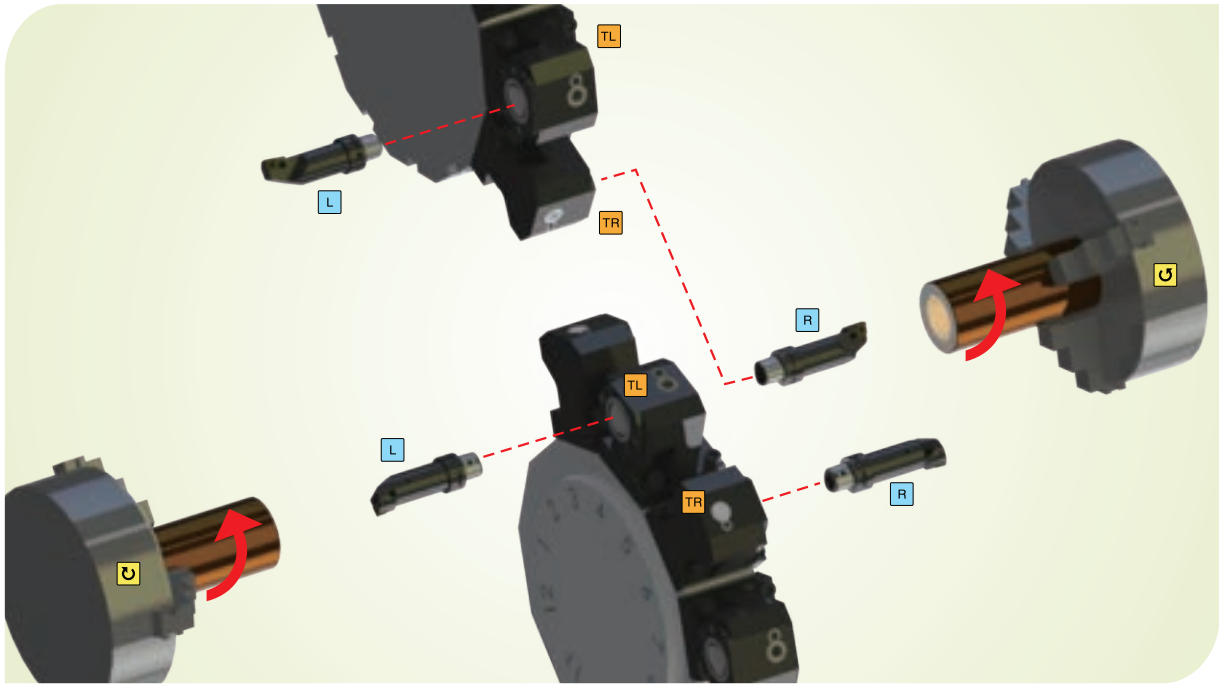

內圓裝夾 ↑  
Internal setup

外圓裝夾 ↓  
Outer setup

- L 左手型刀具  
Left-hand type tool
- R 右手型刀具  
Right-hand type tool
- TL 左手型夾緊單元  
Left-hand type clamping unit
- TR 右手型夾緊單元  
Right-hand type clamping unit
- U 主軸順時針旋轉  
Clockwise spindle rotation
- G 主軸逆時針旋轉  
Counter-clockwise spindle rotation

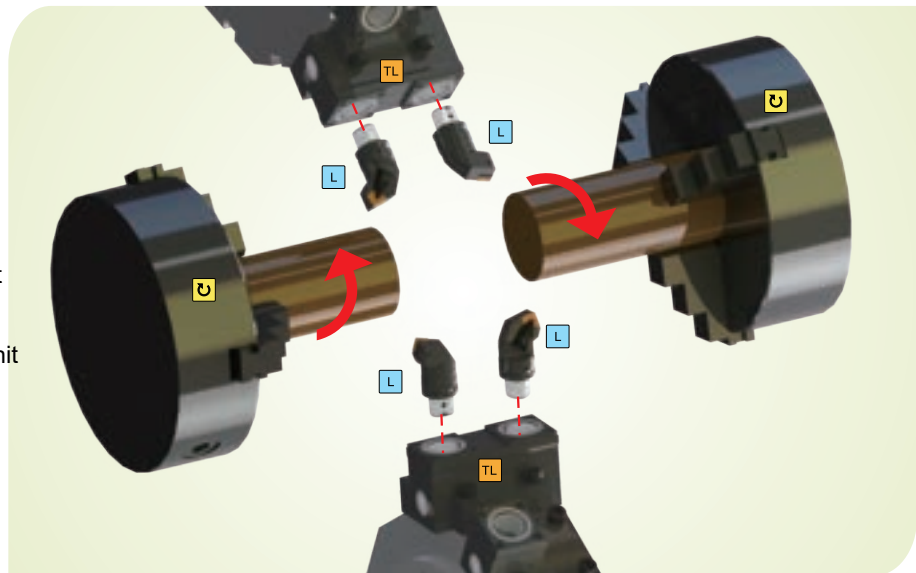

## ● 如何選擇夾緊單元 How to choose clamping unit

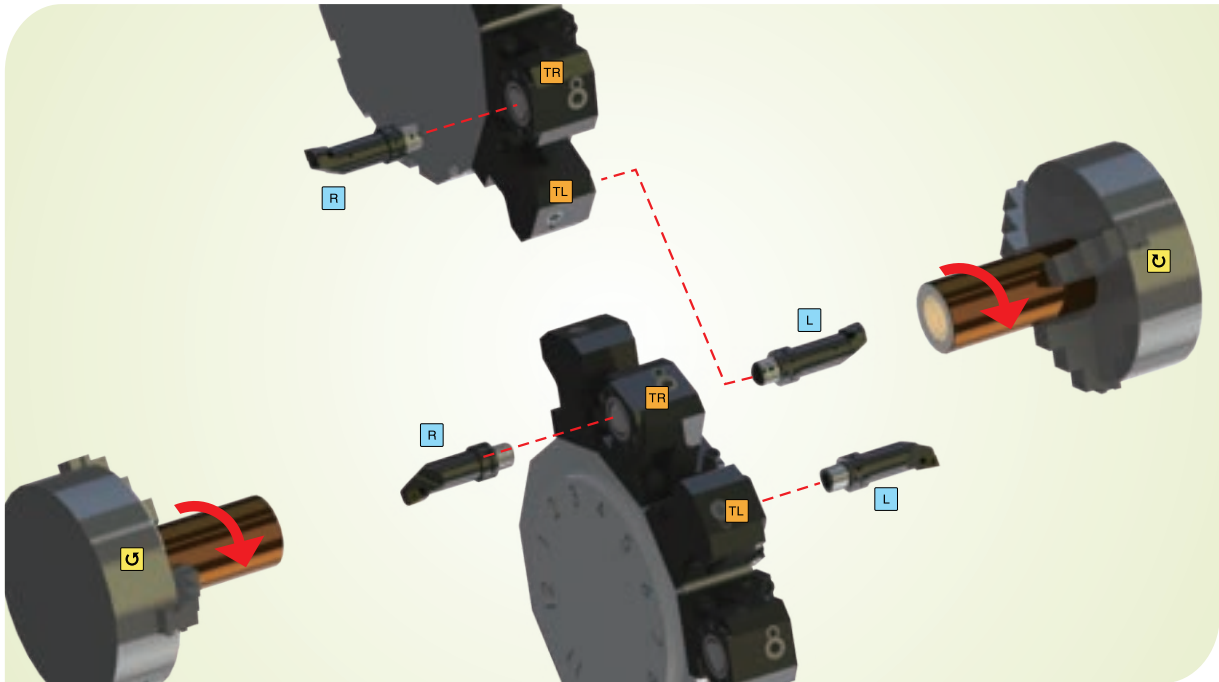

內圓裝夾 ↑  
Internal setup

外圓裝夾 ↓  
Outer setup

- L 左手型刀具  
Left-hand type tool
- R 右手型刀具  
Right-hand type tool
- TL 左手型夾緊單元  
Left-hand type clamping unit
- TR 右手型夾緊單元  
Right-hand type clamping unit
- ⤵ 主軸順時針旋轉  
Clockwise spindle rotation
- ⤴ 主軸逆時針旋轉  
Counter-clockwise spindle rotation

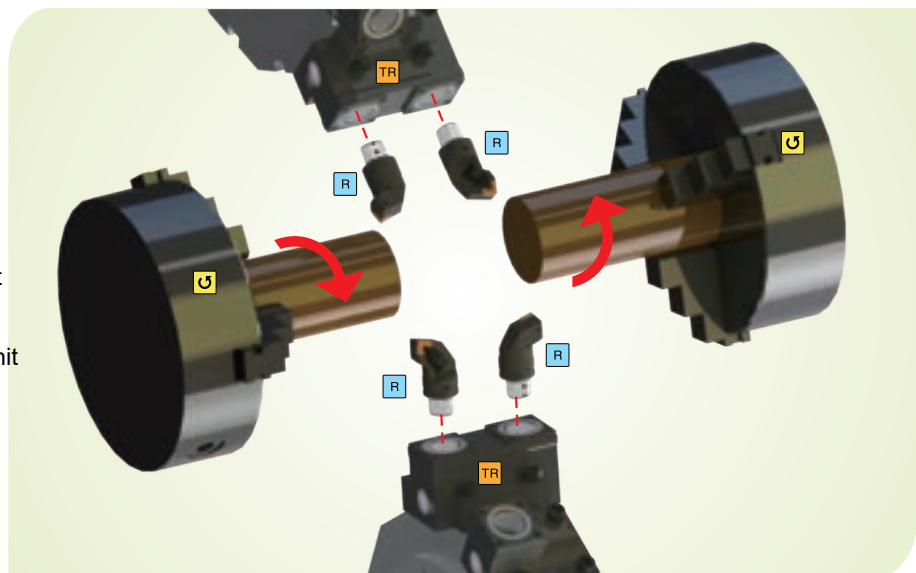

PCLNR/L-HP

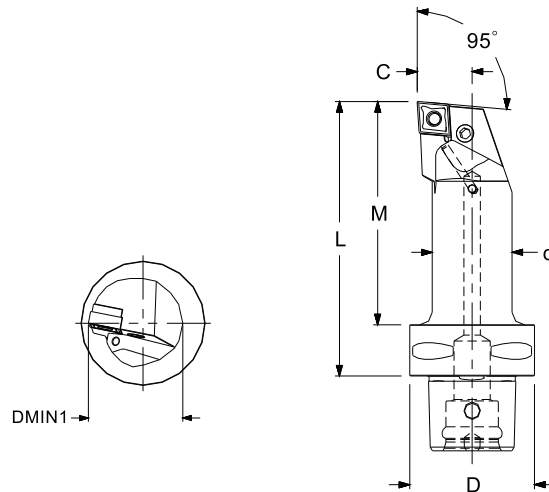

訂貨型號 Order Code	D	d	L	C	M	DMIN1	Kg	刀片型號 Insert Type
C4-PCLNR/L-13080-09HP	40	20	80	13	51.9	25	0.38	CNMG090308
C5-PCLNR/L-13080-09HP	50	20	80	13	50.6	25	0.56	CNMG090308
C3-PCLNR/L-17090-12HP	32	25	90	17	71.8	32	0.34	CNMG120408
C3-PCLNR/L-22064-12HP	32	32	64	22	48	40	0.33	CNMG120408
C3-PCLNR/L-22096-12HP	32	32	96	22	80	40	0.51	CNMG120408
C4-PCLNR/L-17090-12HP	40	25	90	17	63.4	32	0.46	CNMG120408
C4-PCLNR/L-22110-12HP	40	32	110	22	86.6	40	0.71	CNMG120408
C4-PCLNR/L-27080-12HP	40	40	80	27	59	50	0.66	CNMG120408
C4-PCLNR/L-27120-12HP	40	40	120	27	99	50	1.02	CNMG120408
C5-PCLNR/L-17090-12HP	50	25	90	17	61.3	32	0.65	CNMG120408
C5-PCLNR/L-22110-12HP	50	32	110	22	82.2	40	0.89	CNMG120408
C5-PCLNR/L-27140-12HP	50	40	140	27	115.6	50	1.39	CNMG120408
C5-PCLNR/L-35100-12HP	50	50	100	35	79	63	1.32	CNMG120408
C6-PCLNR/L-17100-12HP	63	25	100	17	67.5	32	1.03	CNMG120408
C6-PCLNR/L-22110-12HP	63	32	110	22	78.5	40	1.24	CNMG120408
C5-PCLNR/L-35150-16HP	50	50	150	35	129	63	2.02	CNMG160612
C6-PCLNR/L-27140-16HP	63	40	140	27	109.5	50	1.68	CNMG160612
C6-PCLNR/L-35175-16HP	63	50	175	35	146.7	63	2.71	CNMG160612

**DCLNR/L**

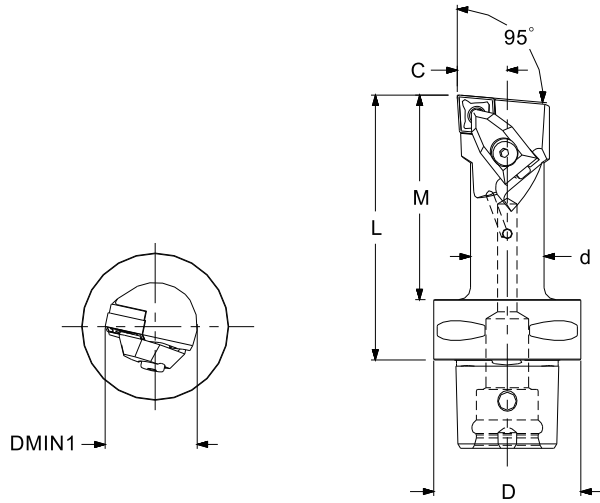

訂貨型號 Order Code	D	d	L	C	M	DMIN1	Kg	刀片型號 Insert Type
C4-DCLNR/L-13080-09	40	20	80	13	57	25	0.33	CNMG090308
C5-DCLNR/L-13080-09	50	20	80	13	56	25	0.6	CNMG090308
C4-DCLNR/L-17090-12	40	25	90	17	68	32	0.46	CNMG120408
C5-DCLNR/L-17090-12	50	25	90	17	66	32	0.64	CNMG120408
C6-DCLNR/L-17100-12	63	25	100	17	72	32	0.9	CNMG120408
C6-DCLNR/L-27140-16	63	40	140	27	114	50	1.7	CNMG160612

PCLNR/L-M1

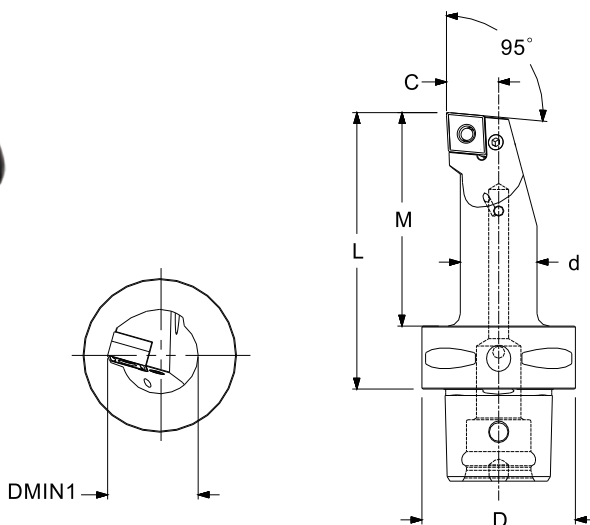

訂貨型號 Order Code	D	d	L	C	M	DMIN1	Kg	刀片型號 Insert Type
C4-PCLNR/L-13080-09M1	40	20	80	13	52	25	0.38	CNMG090308
C5-PCLNR/L-13080-09M1	50	20	80	13	51	25	0.56	CNMG090308
C3-PCLNR/L-17090-12M1	32	25	90	17	72	32	0.34	CNMG120408
C3-PCLNR/L-22064-12M1	32	32	64	22	48	40	0.33	CNMG120408
C3-PCLNR/L-22096-12M1	32	32	96	22	80	40	0.51	CNMG120408
C4-PCLNR/L-17090-12M1	40	25	90	17	64	32	0.46	CNMG120408
C4-PCLNR/L-22110-12M1	40	32	110	22	87	40	0.71	CNMG120408
C4-PCLNR/L-27080-12M1	40	40	80	27	59	50	0.66	CNMG120408
C4-PCLNR/L-27120-12M1	40	40	120	27	99	50	1.02	CNMG120408
C5-PCLNR/L-17090-12M1	50	25	90	17	61	32	0.65	CNMG120408
C5-PCLNR/L-22110-12M1	50	32	110	22	82	40	0.89	CNMG120408
C5-PCLNR/L-27140-12M1	50	40	140	27	115	50	1.39	CNMG120408
C5-PCLNR/L-35100-12M1	50	50	100	35	79	63	1.32	CNMG120408
C6-PCLNR/L-17100-12M1	63	25	100	17	68	32	1.03	CNMG120408
C6-PCLNR/L-22110-12M1	63	32	110	22	78	40	1.24	CNMG120408
C5-PCLNR/L-35150-16M1	50	50	150	35	129	63	1.32	CNMG160612
C6-PCLNR/L-27140-16M1	63	40	140	27	110	50	1.68	CNMG160612
C6-PCLNR/L-35175-16M1	63	50	175	35	147	63	2.71	CNMG160612

PDUNR/L-HP

內孔刀具  
Boring Bar Holder

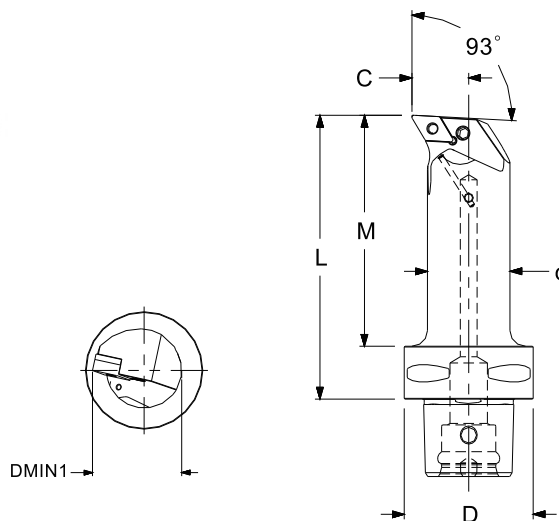

訂貨型號 Order Code	D	d	L	C	M	DMIN1	Kg	刀片型號 Insert Type
C3-PDUNR/L-17090-11HP	32	25	90	17	71.8	32	0.34	DNMG110408
C4-PDUNR/L-17090-11HP	40	25	90	17	63.4	32	0.45	DNMG110408
C4-PDUNR/L-22110-11HP	40	32	110	22	86.6	40	0.72	DNMG110408
C5-PDUNR/L-17090-11HP	50	25	90	17	61.3	32	0.65	DNMG110408
C5-PDUNR/L-22110-11HP	50	32	110	22	82.2	40	0.9	DNMG110408
C6-PDUNR/L-17100-11HP	63	25	100	17	67.5	32	1.04	DNMG110408
C4-PDUNR/L-27080-15HP	40	40	80	27	59	50	0.65	DNMG150608
C4-PDUNR/L-27120-15HP	40	40	120	27	99	50	1	DNMG150608
C5-PDUNR/L-27140-15HP	50	40	140	27	115.6	50	1.38	DNMG150608
C5-PDUNR/L-35100-15HP	50	50	100	35	79	63	1.35	DNMG150608
C5-PDUNR/L-35150-15HP	50	50	150	35	129	63	2.07	DNMG150608
C6-PDUNR/L-22110-15HP	63	32	110	22	78.5	40	1.23	DNMG150608
C6-PDUNR/L-27140-15HP	63	40	140	27	109.5	50	1.71	DNMG150608
C6-PDUNR/L-35175-15HP	63	50	175	35	146.7	63	2.77	DNMG150608

**DDUNR/L**

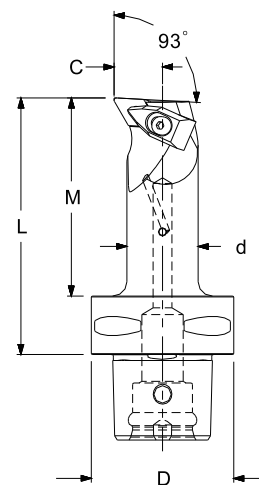
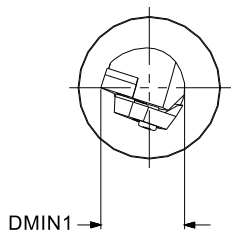

訂貨型號 Order Code	D	d	L	C	M	DMIN1	Kg	刀片型號 Insert Type
C4-DDUNR/L-17090-11	40	25	90	17	68	32	0.46	DNMG110408
C5-DDUNR/L-17090-11	50	25	90	17	66	32	0.64	DNMG110408
C4-DDUNR/L-27080-15	40	39.7	80	27	59	50	0.64	DNMG150608
C5-DDUNR/L-27140-15	50	40	140	27	118	50	1.3	DNMG150608
C6-DDUNR/L-27140-15	63	40	140	27	114	50	1.69	DNMG150608



PDUNR/L-M1

內孔刀具  
Boring Bar Holder

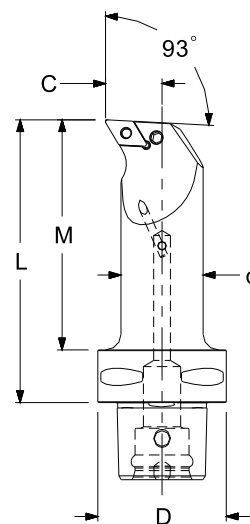
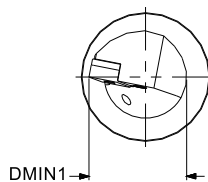

訂貨型號 Order Code	D	d	L	C	M	DMIN1	Kg	刀片型號 Insert Type
C3-PDUNR/L-17090-11M1	32	25	90	17	72	32	0.46	DNMG110408
C4-PDUNR/L-17090-11M1	40	25	90	17	63	32	0.46	DNMG110408
C4-PDUNR/L-22110-11M1	40	32	110	22	87	40	0.71	DNMG110408
C5-PDUNR/L-17090-11M1	50	25	90	17	61	32	0.65	DNMG110408
C5-PDUNR/L-22110-11M1	50	32	110	22	82	40	0.89	DNMG110408
C6-PDUNR/L-17100-11M1	63	25	100	17	67	32	1.03	DNMG110408
C4-PDUNR/L-27080-15M1	40	40	80	27	59	50	0.64	DNMG150608
C4-PDUNR/L-27120-15M1	40	40	120	27	99	50	0.99	DNMG150608
C5-PDUNR/L-27140-15M1	50	40	140	27	115	50	1.37	DNMG150608
C5-PDUNR/L-35100-15M1	50	50	100	35	79	63	1.32	DNMG150608
C5-PDUNR/L-35150-15M1	50	50	150	35	129	63	2.04	DNMG150608
C6-PDUNR/L-22110-15M1	63	32	110	22	78	40	1.22	DNMG150608
C6-PDUNR/L-27140-15M1	63	40	140	27	110	50	1.7	DNMG150608
C6-PDUNR/L-35175-15M1	63	50	175	35	147	63	2.74	DNMG150608

**PSKNR/L-HP**

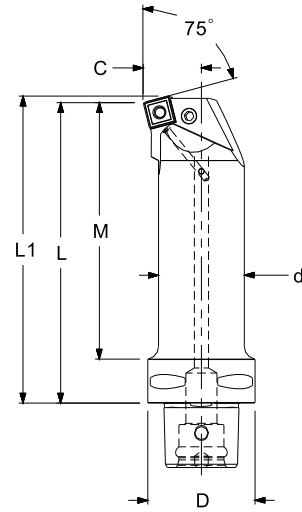
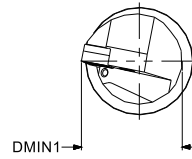

訂貨型號 Order Code	D	d	L	L1	C	M	DMIN1	Kg	刀片型號 Insert Type
C4-PSKNR/L-17090-12HP	40	25	90	93.1	17	63.4	32	0.47	SNMG120408
C4-PSKNR/L-22110-12HP	40	32	110	113.1	22	86.6	40	0.73	SNMG120408
C5-PSKNR/L-17090-12HP	50	25	90	93.1	17	61.3	32	0.66	SNMG120408
C5-PSKNR/L-22110-12HP	50	32	110	113.1	22	82.2	40	0.92	SNMG120408
C5-PSKNR/L-27140-12HP	50	40	140	143.1	27	115.6	50	1.42	SNMG120408
C6-PSKNR/L-22110-12HP	63	32	110	113.1	22	78.5	40	1.26	SNMG120408
C6-PSKNR/L-35175-15HP	63	50	175	178.8	35	146.7	63	2.81	SNMG150608

**PSKNR/L-M1**

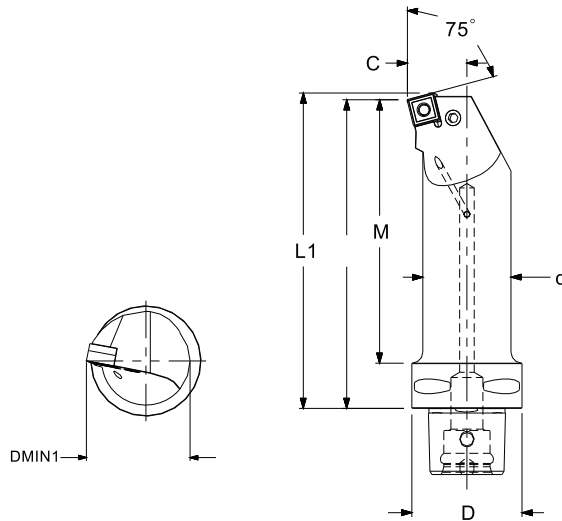

訂貨型號 Order Code	D	d	L	L1	C	M	DMIN1	Kg	刀片型號 Insert Type
C4-PSKNL-22110-12M1	40	32	110	113.1	22	87	40	0.72	SNMG120408
C4-PSKNR-17090-12M1	40	25	90	93.1	17	63	32	0.47	SNMG120408
C5-PSKNR/L-27140-12M1	50	40	140	143.1	27	116	50	1.4	SNMG120408
C5-PSKNR-17090-12M1	50	25	90	93.1	17	61	32	0.66	SNMG120408
C5-PSKNR-22110-12M1	50	32	110	113.1	22	82	40	0.9	SNMG120408
C6-PSKNR-22110-12M1	63	32	110	113.1	22	78	40	1.25	SNMG120408
C6-PSKNR/L-35175-15M1	63	50	175	178.8	35	147	63	2.76	SNMG150608

**DTFNR/L**

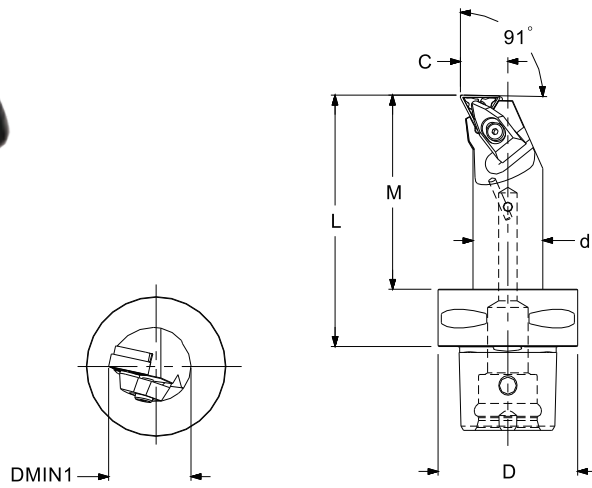

訂貨型號 Order Code	D	d	L	C	M	DMIN1	Kg	刀片型號 Insert Type
C4-DTFNR/L-17090-16	40	25	90	17	68	32	0.55	TNMG160408
C5-DTFNR/L-17090-16	50	25	90	17	66	32	0.55	TNMG160408

**PTFNR/L-W**

內孔刀具  
Boring Bar Holder

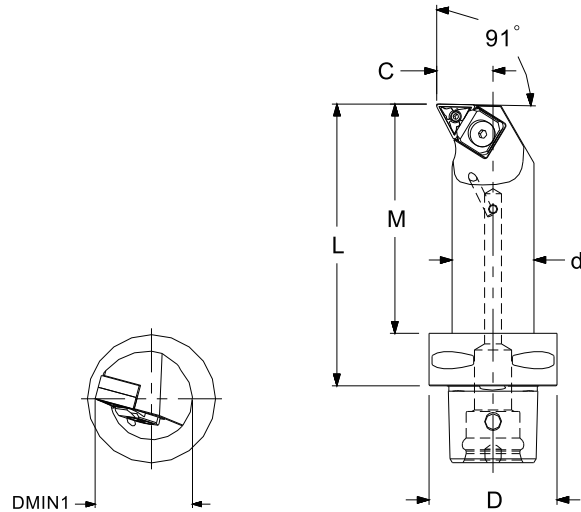

訂貨型號 Order Code	D	d	L	C	M	DMIN1	Kg	刀片型號 Insert Type
C3-PTFNR-17090-16W	32	25	90	17	75	32	0.34	TNMG160408
C4-PTFNR/L-17090-16W	40	25	90	17	69	32	0.45	TNMG160408
C4-PTFNR/L-22110-16W	40	32	110	22	89	40	0.69	TNMG160408
C4-PTFNR/L-27120-16W	40	40	120	27	100	50	0.8	TNMG160408
C5-PTFNR/L-17090-16W	50	25	90	17	67	32	0.65	TNMG160408
C5-PTFNR/L-22110-16W	50	32	110	22	88	40	0.87	TNMG160408
C5-PTFNR/L-27140-16W	50	40	140	27	119	50	1.34	TNMG160408
C6-PTFNR/L-22110-16W	63	32	110	22	84	40	1.4	TNMG160408
C6-PTFNR/L-27140-16W	63	40	140	27	115	50	1.7	TNMG160408
C5-PTFNR-27140-22W	50	40	140	27	119	50	1.34	TNMG220408
C6-PTFNR/L-27140-22W	63	40	140	27	115	50	1.7	TNMG220408
C6-PTFNR/L-35175-22W	63	50	175	35	152	63	2.7	TNMG220408

MVUNR/L

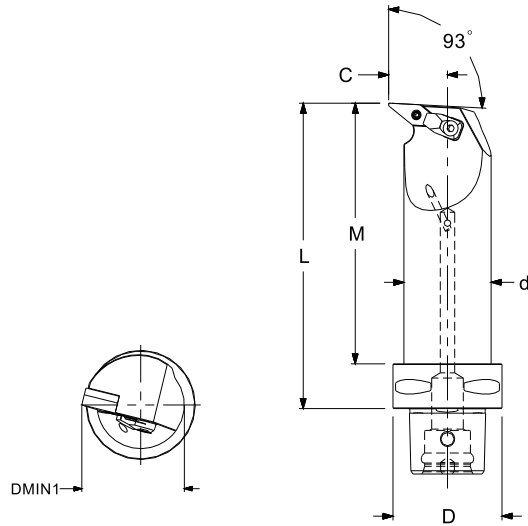

訂貨型號 Order Code	D	d	L	C	M	DMIN1	Kg	刀片型號 Insert Type
C4-MVUNR/L-27120-16	40	40	120	27	100	50	0.5	VNMG160408
C5-MVUNR/L-27140-16	50	40	140	27	119	50	0.65	VNMG160408
C5-MVUNR/L-35150-16	50	50	150	35	131	63	0.65	VNMG160408
C6-MVUNL-22120-16	63	32	120	22	94	40	1.2	VNMG160408
C6-MVUNR-35175-16	63	50	175	35	152	63	1.7	VNMG160408

**PWLNR/L-HP**

內孔刀具  
Boring Bar Holder

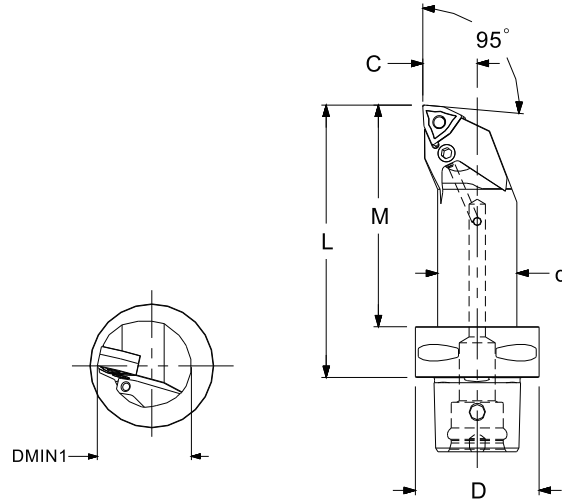

訂貨型號 Order Code	D	d	L	C	M	DMIN1	Kg	刀片型號 Insert Type
C4-PWLNR/L-17090-08HP	40	25	90	17	63.4	32	0.46	WNMG080408
C5-PWLNR/L-22110-08HP	50	32	110	22	82.2	40	0.88	WNMG080408

**DWLNR/L**

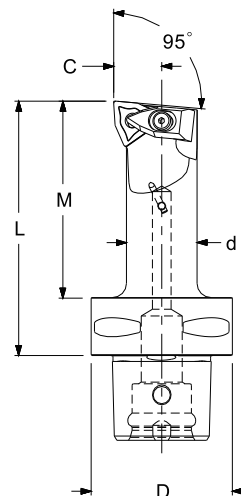
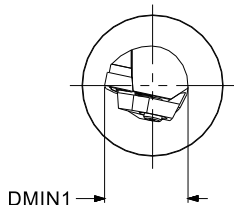

訂貨型號 Order Code	D	d	L	C	M	DMIN1	Kg	刀片型號 Insert Type
C4-DWLNR/L-13075-06	40	20	75	13	52	27	0.33	WNMG060408
C4-DWLNR/L-17090-08	40	25	90	17	68	33	0.46	WNMG080408
C5-DWLNR/L-17090-08	50	25	90	17	66	33	0.55	WNMG080408



MWLNR/L

內孔刀具  
Boring Bar Holder

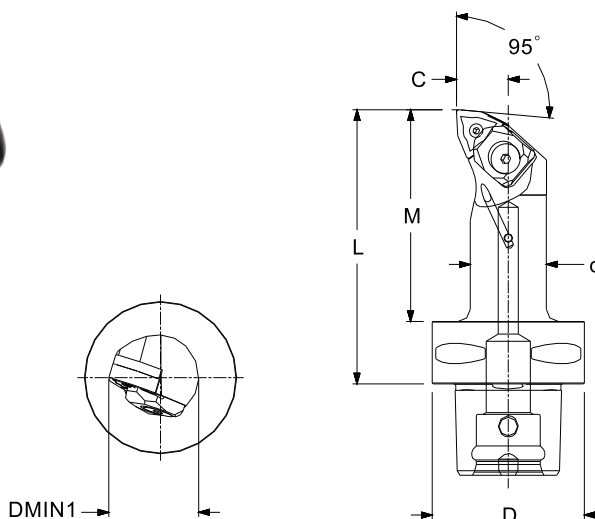

訂貨型號 Order Code	D	d	L	C	M	DMIN1	Kg	刀片型號 Insert Type
C3-MWLNR/L-13075-06	32	20	75	13	59	25	0.3	WNMG060408
C4-MWLNR/L-13075-06	40	20	75	13	53	25	0.5	WNMG060408
C4-MWLNR/L-17090-06M1	40	25	90	17	69	32	0.5	WNMG060408
C4-MWLNR/L-17090-08	40	25	90	17	69	32	0.5	WNMG080408
C4-MWLNR/L-22110-08	40	32	110	22	89	40	0.5	WNMG080408
C4-MWLNR/L-27120-08	40	40	120	27	100	50	0.5	WNMG080408
C5-MWLNR/L-17090-08	50	25	90	17	67	32	0.65	WNMG080408
C5-MWLNR/L-22110-08	50	32	110	22	88	40	0.65	WNMG080408
C5-MWLNR/L-27140-08	50	40	140	27	119	50	0.65	WNMG080408

**SCLCR/L-HP**

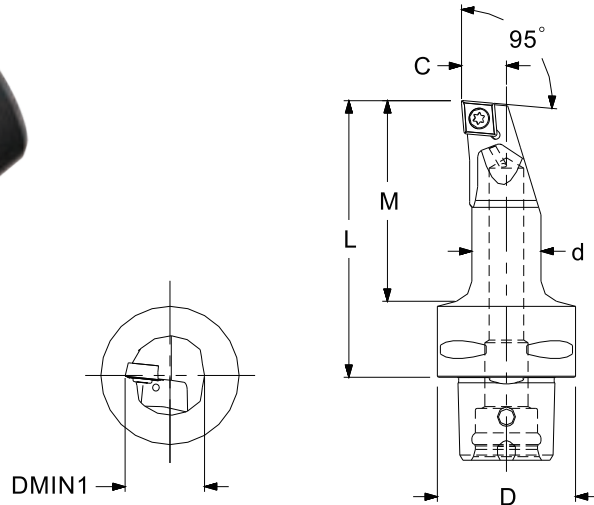

訂貨型號 Order Code	D	d	L	C	M	DMIN1	Kg	刀片型號 Insert Type
C3-SCLCR/L-11065-09HP	32	16	65	11	48	21.5	0.17	CCMT09T308
C4-SCLCR/L-11070-09HP	40	16	70	11	47	21.5	0.35	CCMT09T308
C4-SCLCR/L-13080-09HP	40	20	80	13	57	25	0.35	CCMT09T308
C5-SCLCR/L-11070-09HP	50	16	70	11	46	21.5	0.5	CCMT09T308
C5-SCLCR/L-13080-09HP	50	20	80	13	56	25	0.5	CCMT09T308
C4-SCLCR/L-17090-12HP	40	25	90	17	69	32	0.35	CCMT120408
C5-SCLCR/L-17090-12HP	50	25	90	17	67	32	0.5	CCMT120408

SCLCR/L

內孔刀具  
Boring Bar Holder

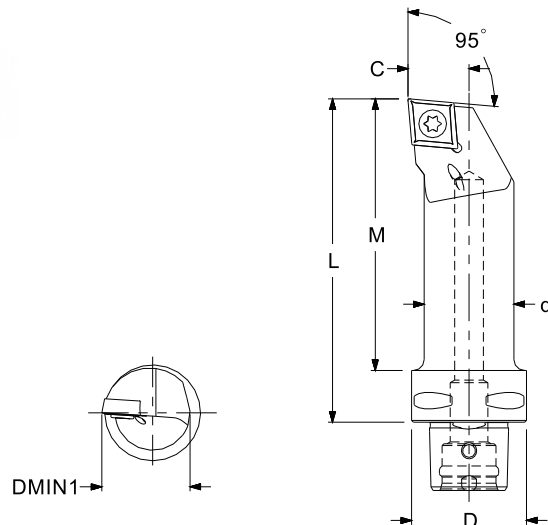

訂貨型號 Order Code	D	d	L	C	M	DMIN1	Kg	刀片型號 Insert Type
C3-SCLCL-17090-09	32	25	90	17	74	32	0.3	CCMT09T308
C3-SCLCR/L-11065-09	32	16	65	11	48	20	0.3	CCMT09T308
C3-SCLCR/L-13075-09	32	20	75	13	58	25	0.3	CCMT09T308
C4-SCLCR/L-11070-09	40	16	70	11	47	20	0.5	CCMT09T308
C4-SCLCR/L-13080-09	40	20	80	13	57	25	0.5	CCMT09T308
C4-SCLCR/L-17090-09	40	25	90	17	68	32	0.5	CCMT09T308
C4-SCLCR/L-27080-09	40	40	80	27	60	50	0.5	CCMT09T308
C5-SCLCR/L-11070-09	50	16	70	11	46	20	0.65	CCMT09T308
C5-SCLCR/L-13080-09	50	20	80	13	56	25	0.65	CCMT09T308
C5-SCLCR/L-17090-09	50	25	90	17	67	32	0.65	CCMT09T308
C5-SCLCR-35100-09	50	50	100	35	80	63	0.65	CCMT09T308
C3-SCLCR-17090-12	32	25	90	17	74	32	0.3	CCMT120408
C3-SCLCR-22096-12	32	32	96	22	81	40	0.3	CCMT120408
C4-SCLCR/L-17090-12	40	25	90	17	68	32	0.5	CCMT120408
C4-SCLCR/L-22110-12	40	32	110	22	89	40	0.5	CCMT120408
C4-SCLCR/L-27080-12	40	40	80	27	60	50	0.5	CCMT120408
C5-SCLCR/L-17090-12	50	25	90	17	67	32	0.65	CCMT120408
C5-SCLCR/L-22110-12	50	32	110	22	88	40	0.65	CCMT120408
C5-SCLCR/L-27140-12	50	40	140	27	119	50	0.65	CCMT120408
C5-SCLCR-35100-12	50	50	100	35	80	63	0.65	CCMT120408

**SDUCR/L-HP**

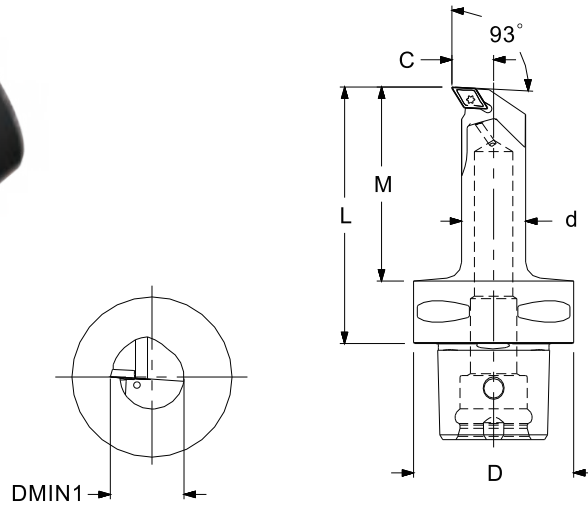

訂貨型號 Order Code	D	d	L	C	M	DMIN1	Kg	刀片型號 Insert Type
C4-SDUCR/L-13080-07HP	40	20	80	13	58	25	0.35	DCMT070204
C5-SDUCR/L-13080-07HP	50	20	80	13	56	25	0.5	DCMT070204
C4-SDUCR/L-13080-11HP	40	20	80	13	58	25	0.35	DCMT11T308
C4-SDUCR/L-17090-11HP	40	25	90	17	69	32	0.35	DCMT11T308
C5-SDUCR/L-13080-11HP	50	20	80	13	56	25	0.5	DCMT11T308
C5-SDUCR/L-17090-11HP	50	25	90	17	67	32	0.5	DCMT11T308

SDUCR/L

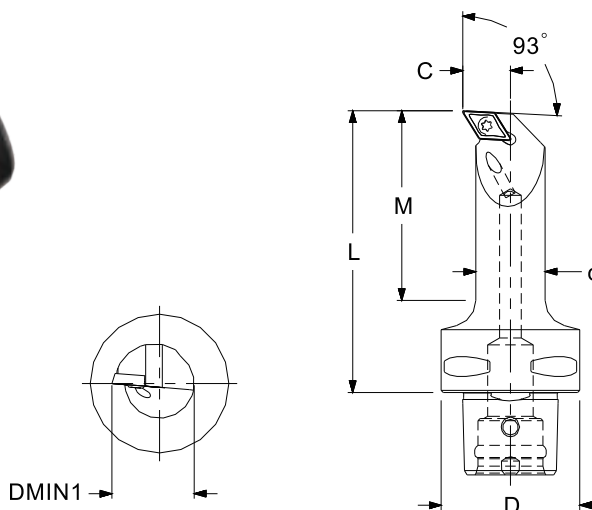

訂貨型號 Order Code	D	d	L	C	M	DMIN1	Kg	刀片型號 Insert Type
C3-SDUCR/L-11065-07	32	16	65	11	48	20	0.3	DCMT070204
C4-SDUCR/L-11070-07	40	16	70	11	47	20	0.5	DCMT070204
C5-SDUCR/L-11070-07	50	16	70	11	46	20	0.65	DCMT070204
C3-SDUCR/L-13075-11	32	20	75	13	58	25	0.3	DCMT11T308
C3-SDUCR/L-17090-11	32	25	90	17	73	32	0.3	DCMT11T308
C3-SDUCR/L-22096-11	32	32	96	22	81	40	0.3	DCMT11T308
C4-SDUCR/L-13080-11	40	20	80	13	57	25	0.5	DCMT11T308
C4-SDUCR/L-17090-11	40	25	90	17	68	32	0.5	DCMT11T308
C4-SDUCR/L-22110-11	40	32	110	22	89	40	0.5	DCMT11T308
C4-SDUCR/L-27080-11	40	40	80	27	60	50	0.5	DCMT11T308
C5-SDUCR/L-13080-11	50	20	80	13	56	25	0.65	DCMT11T308
C5-SDUCR/L-17090-11	50	25	90	17	67	32	0.65	DCMT11T308
C5-SDUCR/L-22110-11	50	32	110	22	88	40	0.65	DCMT11T308
C5-SDUCR/L-35100-11	50	50	100	35	80	63	0.65	DCMT11T308

**SSKCR**

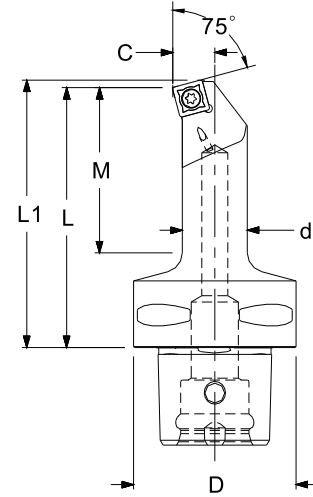
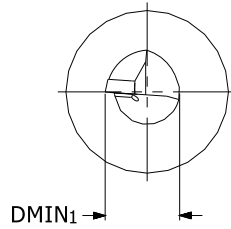

訂貨型號 Order Code	D	d	L	L1	C	M	DMIN1	Kg	刀片型號 Insert Type
C4-SSKCR-13080-09	40	20	80	82.2	13	58	25	0.36	SCMT09T308
C5-SSKCR-13080-09	50	20	80	82.2	13	56	25	0.54	SCMT09T308

**STFCR/L-HPB**

內孔刀具  
Boring Bar Holder

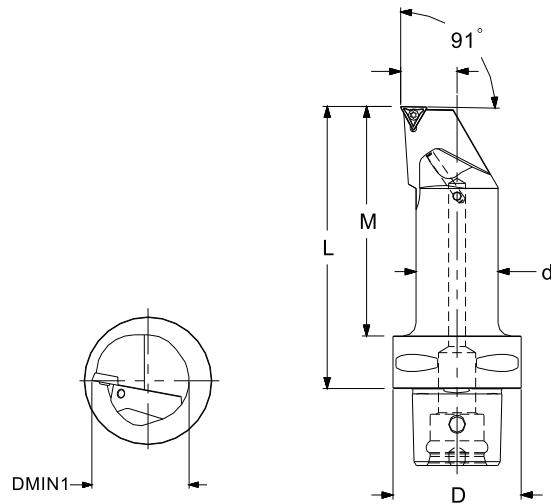

訂貨型號 Order Code	D	d	L	C	M	DMIN1	Kg	刀片型號 Insert Type
C4-STFCR/L-11070-11HPB1	40	16	70	11	47	20	0.35	TCMT110304
C4-STFCR/L-13080-11HPB1	40	20	80	13	57	25	0.35	TCMT110304
C4-STFCR/L-17090-16HP	40	25	90	17	69	32	0.35	TCMT16T308
C5-STFCR/L-17090-16HP	50	25	90	17	67	32	0.5	TCMT16T308
C5-STFCR/L-22110-16HP	50	32	110	22	88	40	0.5	TCMT16T308

STFCR/L-B

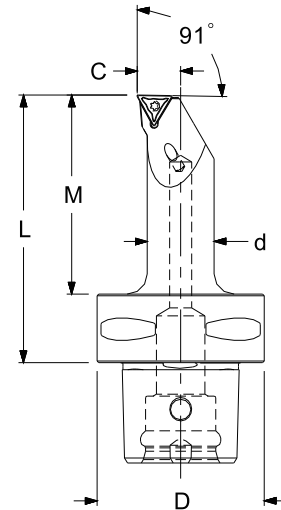
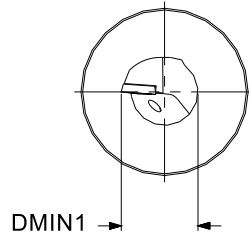

訂貨型號 Order Code	D	d	L	C	M	DMIN1	Kg	刀片型號 Insert Type
C3-STFCR/L-11065-11-B1	32	16	65	11	48	20	0.15	TCMT110304
C3-STFCR/L-11065-11	32	16	65	11	48	20	0.15	TCMT110204
C4-STFCR/L-11070-11	40	16	70	11	47	20	0.31	TCMT110204
C4-STFCR/L-11070-11-B1	40	16	70	11	47	20	0.34	TCMT110304
C4-STFCR/L-13080-11	40	20	80	13	57	25	0.36	TCMT110204
C4-STFCR/L-13080-11-B1	40	20	80	13	57	25	0.36	TCMT110304
C5-STFCR/L-11070-11-B1	50	16	70	11	46	20	0.45	TCMT110304
C5-STFCR/L-13080-11-B1	50	20	80	13	56	25	0.54	TCMT110304
C5-STFCR-11070-11	50	16	70	11	46	20	0.45	TCMT110204
C5-STFCR-13080-11	50	20	80	13	56	25	0.54	TCMT110204
C3-STFCR-17090-16	32	25	90	17	74	32	0.34	TCMT16T308
C4-STFCR/L-17090-16	40	25	90	17	68	32	0.45	TCMT16T308
C4-STFCR/L-22110-16	40	32	110	22	89	40	0.69	TCMT16T308
C5-STFCR/L-17090-16	50	25	90	17	67	32	0.65	TCMT16T308
C5-STFCR/L-22110-16	50	32	110	22	88	40	0.87	TCMT16T308



SVQBR/L-HP

內孔刀具  
Boring Bar Holder

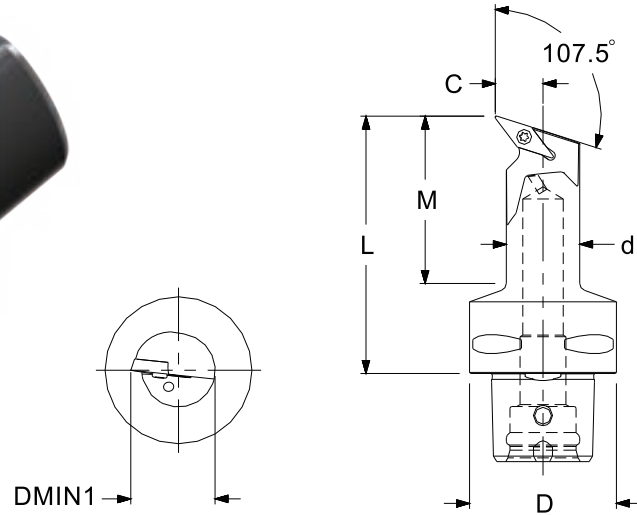

訂貨型號 Order Code	D	d	L	C	M	DMIN1	Kg	刀片型號 Insert Type
C4-SVQBR/L-13070-11HPB1	40	20	70	13	47	25	0.35	VBMT110304
C4-SVQBR/L-18090-16HP	40	25	90	18	68	33	0.35	VBMT160408
C5-SVQBR/L-18090-16HP	50	25	90	18	67	33	0.5	VBMT160408
C6-SVQBR/L-22120-16HP	63	32	120	22	94	40	1.25	VBMT160408

**SVQBR/L-B**

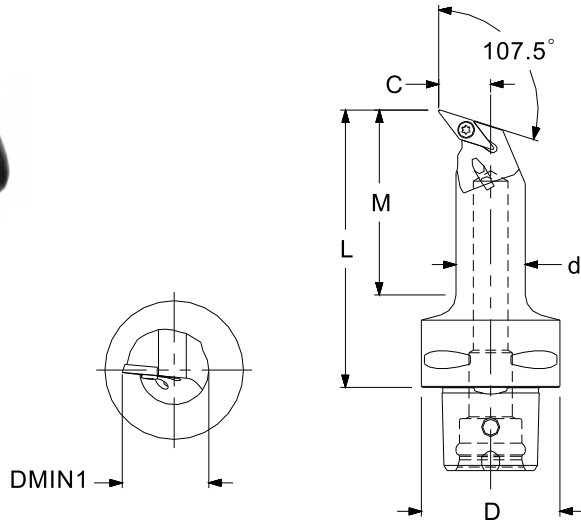

訂貨型號 Order Code	D	d	L	C	M	DMIN1	Kg	刀片型號 Insert Type
C3-SVQBR/L-13070-11-B1	32	16	70	13	53	22	0.3	VBMT110304
C3-SVQBR/L-15080-11-B1	32	20	80	15	63	27	0.3	VBMT110304
C4-SVQBR/L-13070-11-B1	40	20	70	13	47	25	0.5	VBMT110304
C4-SVQBR/L-15080-11-B1	40	20	80	15	57	27	0.5	VBMT110304
C4-SVQBR-13070-11	40	20	70	13	48	25	0.5	VBMT110204
C4-SVQBR-15080-11	40	20	80	15	58	27	0.5	VBMT110204
C5-SVQBR/L-15080-11	50	20	80	15	57	27	0.65	VBMT110204
C5-SVQBR/L-15080-11-B1	50	20	80	15	56	27	0.65	VBMT110304

**SDUCR/L-X**

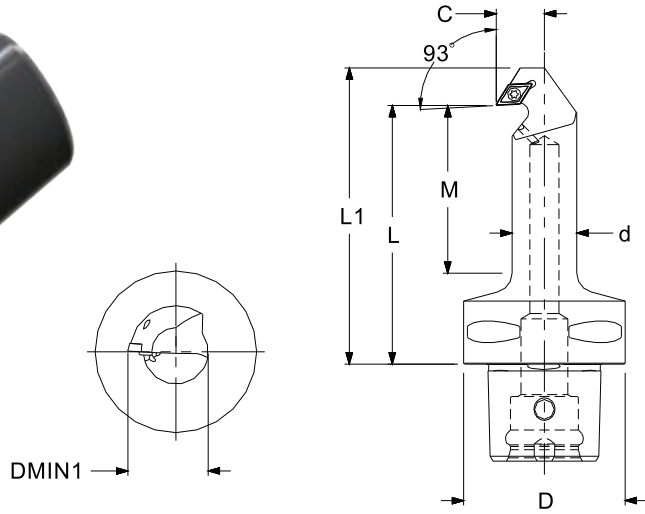

訂貨型號 Order Code	D	d	L	L1	C	M	DMIN1	Kg	刀片型號 Insert Type
C3-SDUCR-15080-07X	32	20	80	91.5	15	63.9	27	0.25	DCMT070204
C4-SDUCR/L-13070-07X	40	16	70	81.5	13	47.3	22	0.35	DCMT070204
C4-SDUCR/L-15080-07X	40	20	80	91.5	15	47.9	27	0.4	DCMT070204
C4-SDUCR/L-18090-07X	40	25	90	101.5	18	68.5	32	0.5	DCMT070204
C5-SDUCR/L-15080-07X	50	20	80	91.5	15	56.5	27	0.6	DCMT070204
C5-SDUCR/L-18090-07X	50	25	90	101.5	18	67.2	32	0.7	DCMT070204

**SNR/L**

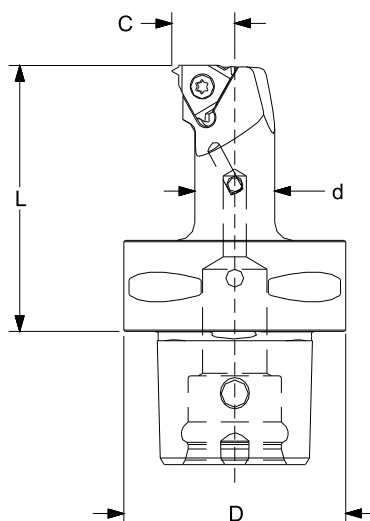

訂貨型號 Order Code	D	d	L	C	Kg	刀片型號 Insert Type
C3-SNR/L-08060-11	32	13	60	8	0.24	11IR ISO(0.35-2.0)
C3-SNR/L-12060-11	32	13	60	12	0.24	11IR ISO(0.35-2.0)
C4-SNR/L-08060-11	40	13	60	8	0.3	11IR ISO(0.35-2.0)
C4-SNR/L-12060-11	40	13	60	12	0.3	11IR ISO(0.35-2.0)
C5-SNR/L-08060-11	50	13	60	8	0.33	11IR ISO(0.35-2.0)
C5-SNR/L-12060-11	50	13	60	12	0.33	11IR ISO(0.35-2.0)
C6-SNR/L-08060-11	63	13	60	8	0.4	11IR ISO(0.35-2.0)
C6-SNR/L-12060-11	63	13	60	12	0.4	11IR ISO(0.35-2.0)
C3-SNR/L-12050-16	32	15	50	12	0.21	16IR ISO
C3-SNR/L-14060-16	32	18	60	14	0.24	16IR ISO
C4-SNR/L-12060-16	40	15	60	12	0.55	16IR ISO
C4-SNR/L-14060-16	40	18	60	14	0.51	16IR ISO
C4-SNR/L-17070-16	40	24	70	17	0.52	16IR ISO
C4-SNR/L-22090-16	40	32	90	22	0.52	16IR ISO
C5-SNR/L-12060-16	50	15	60	12	0.55	16IR ISO
C5-SNR/L-14060-16	50	18	60	14	0.55	16IR ISO
C5-SNR/L-17070-16	50	24	70	17	0.55	16IR ISO
C5-SNR/L-22090-16	50	32	90	22	0.55	16IR ISO
C5-SNR/L-27105-16	50	40	105	27	0.55	16IR ISO
C6-SNR/L-14070-16	63	18	70	14	0.55	16IR ISO
C6-SNR/L-17070-16	63	24	70	17	0.55	16IR ISO
C6-SNR/L-22090-16	63	32	90	22	1.1	16IR ISO
C6-SNR/L-27105-16	63	40	105	27	1.35	16IR ISO

PCLNR/L-HP

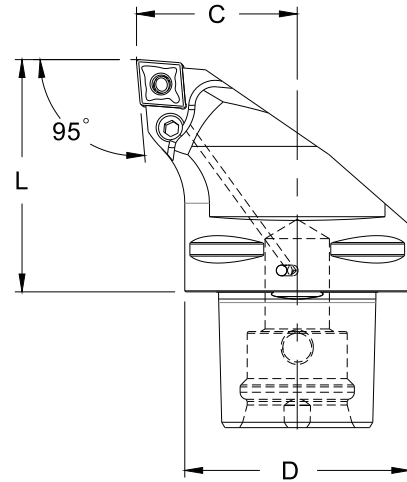
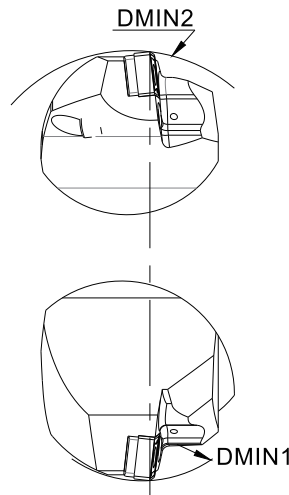

外徑刀具  
Turning Holder

訂貨型號 Order Code	D	L	C	DMIN1	DMIN2	Kg	刀片型號 Insert Type
C4-PCLNR/L-27050-12HP	40	50	27	110	140	0.34	CNMG120408
C5-PCLNR/L-35060-12HP	50	60	35	110	165	0.71	CNMG120408
C6-PCLNR/L-45065-12HP	63	65	45	110	195	1.1	CNMG120408
C5-PCLNR/L-35060-16HP	50	60	35	125	165	0.76	CNMG160612
C6-PCLNR/L-45065-16HP	63	65	45	110	195	1.25	CNMG160612
C6-PCLNR/L-45065-19HP	63	65	45	110	195	1.25	CNMG190612

**DCMNN**

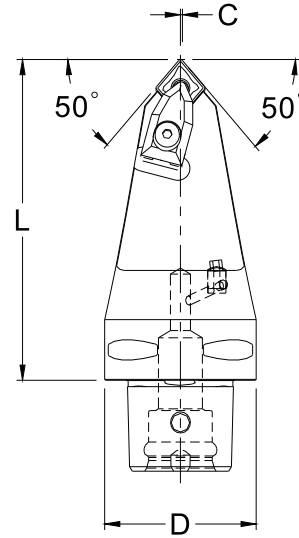

外徑刀具  
Turning Holder

訂貨型號 Order Code	D	L	C	Kg	刀片型號 Insert Type
C5-DCMNN-00105-12	50	105	0	1.09	CNMG120408
C6-DCMNN-00090-12	63	90	0	1.3	CNMG120408
C6-DCMNN-00115-12	63	115	0	1.7	CNMG120408
C6-DCMNN-00090-16	63	90	0	1.3	CNMG160612

DCLNR/L

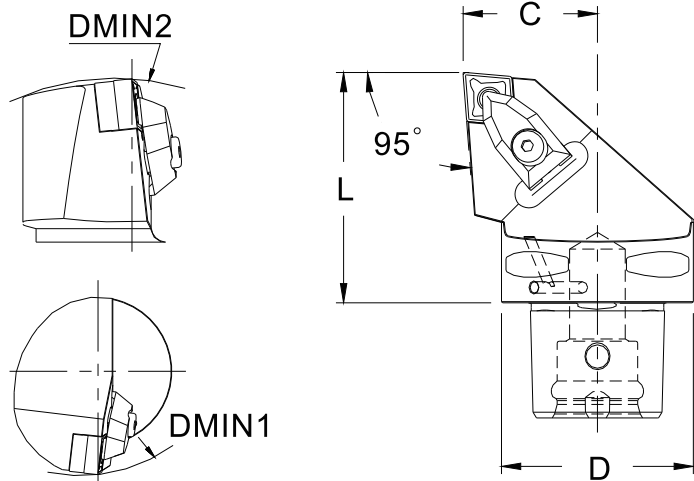

訂貨型號 Order Code	D	L	C	DMIN1	DMIN2	Kg	刀片型號 Insert Type
C4-DCLNR/L-27050-09	40	50	27	60	140	0.33	CNMG090308
C3-DCLNR/L-22045-12	32	45	22	60	121	0.26	CNMG120408
C4-DCLNR/L-27050-12	40	50	27	110	140	0.33	CNMG120408
C5-DCLNR/L-35060-12	50	60	35	110	165	0.87	CNMG120408
C6-DCLNR/L-45065-12	63	65	45	110	190	1.31	CNMG120408
C4-DCLNR/L-27055-16	40	55	27	125	145	0.46	CNMG160612
C5-DCLNR/L-35060-16	50	60	35	125	165	0.71	CNMG160612
C6-DCLNR/L-45065-16	63	65	45	125	190	1.31	CNMG160612
C5-DCLNR/L-35060-19	50	60	35	80	165	0.87	CNMG190612
C6-DCLNR/L-45065-19	63	65	45	81	190	1.31	CNMG190612

**DCRNR/L**

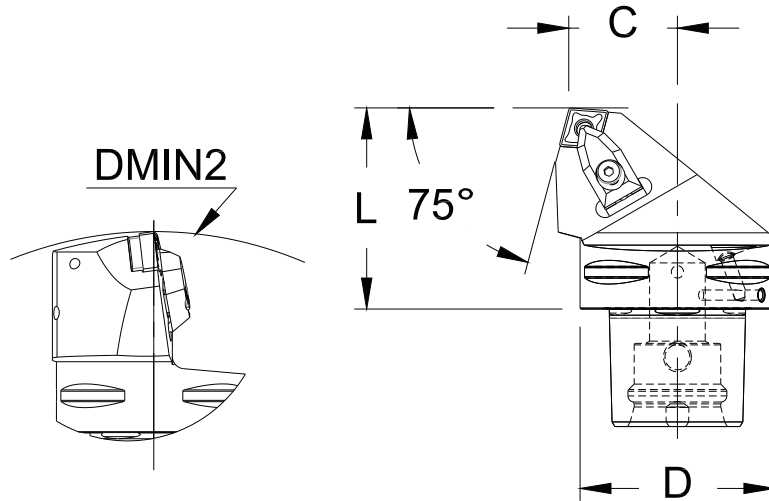

訂貨型號 Order Code	D	L	C	DMIN2	Kg	刀片型號 Insert Type
C4-DCRNR/L-22050-12	40	50	22	10	0.46	CNMG120408
C5-DCRNR/L-27060-12	50	60	27	10	0.87	CNMG120408
C6-DCRNR/L-35065-12	63	65	35	10	1.3	CNMG120408
C5-DCRNR/L-27060-16	50	60	27	10	0.71	CNMG160612
C6-DCRNR/L-35065-16	63	65	35	10	1.3	CNMG160612
C5-DCRNR/L-27060-19	50	60	27	10	0.71	CNMG190612
C6-DCRNR/L-35065-19	63	65	35	10	1.3	CNMG190612



**DCKNR/L**

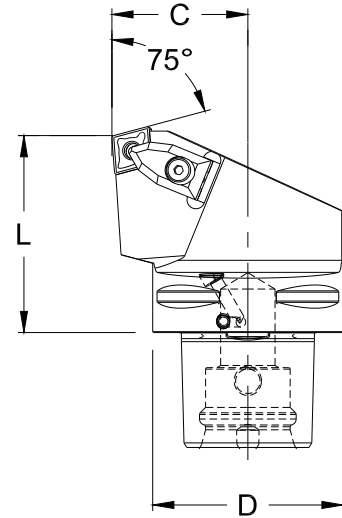
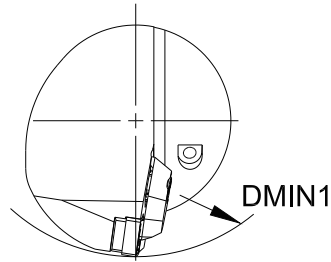

訂貨型號 Order Code	D	L	C	DMIN1	Kg	刀片型號 Insert Type
C4-DCKNR/L-27050-12	40	50	27	110	0.49	CNMG120408
C5-DCKNR/L-35060-12	50	60	35	110	0.85	CNMG120408
C6-DCKNR/L-45065-12	63	65	45	110	1.31	CNMG120408
C5-DCKNR/L-35060-16	50	60	35	125	0.85	CNMG160612
C6-DCKNR/L-45065-16	63	65	45	125	1.31	CNMG160612
C6-DCKNR/L-45065-19	63	65	45	81	1.31	CNMG190612

PCLNR/L

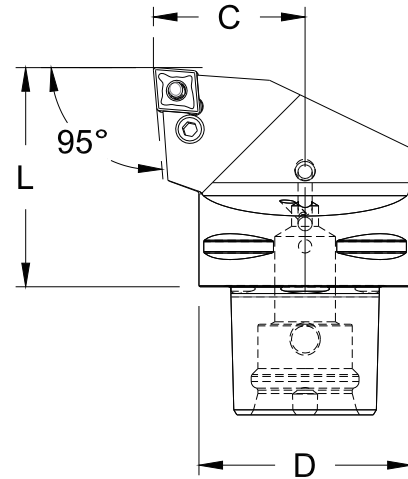
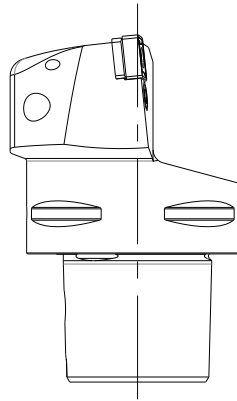

訂貨型號 Order Code	D	L	C	Kg	刀片型號 Insert Type
C3-PCLNR/L-22040-12	32	40	22	0.23	CNMG120408
C4-PCLNR/L-27050-12	40	50	27	0.46	CNMG120408
C5-PCLNR/L-35060-12	50	60	35	0.88	CNMG120408
C6-PCLNR/L-45065-12	63	65	45	1.7	CNMG120408
C4-PCLNR/L-27050-16	40	50	27	0.46	CNMG160612
C5-PCLNR/L-35060-16	50	60	35	0.88	CNMG160612
C6-PCLNR/L-45065-16	63	65	45	1.3	CNMG160612
C5-PCLNR/L-35060-19	50	60	35	0.88	CNMG190612
C6-PCLNR/L-45065-19	63	65	45	1.3	CNMG190612
C5-PCLNR/L-27060-12	50	60	27	0.85	CNMG120408
C6-PCLNR/L-35065-12	63	65	35	1.36	CNMG120408
C5-PCLNR/L-27060-16	50	60	27	0.85	CNMG160612
C6-PCLNR/L-35065-16	63	65	35	1.35	CNMG160612
C5-PCLNR/L-27060-19	50	60	27	0.85	CNMG190612
C6-PCLNR/L-35065-19	63	65	35	1.35	CNMG190612

PDJNR/L-HP

PDMNR/L-HP

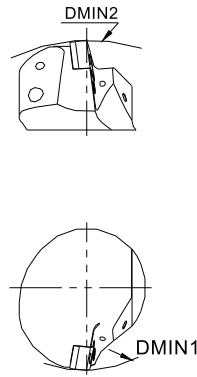

PDJNR/L-HP

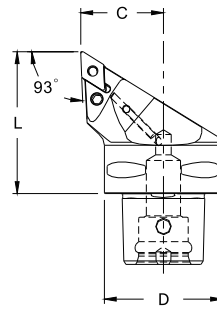

PDMNR/L-HP

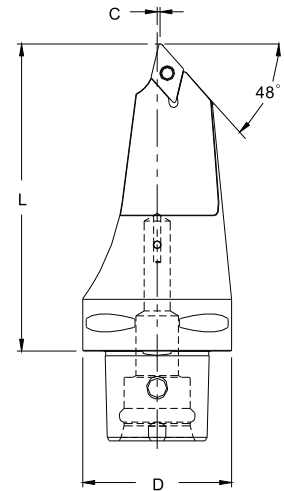

外徑刀具  
Turning Holder

訂貨型號 Order Code	D	L	C	DMIN1	DMIN2	Kg	刀片型號 Insert Type
C4-PDJNR/L-27050-11HP	40	50	27	90	145	0.3	DNMG110408
C5-PDJNR/L-35060-11HP	50	60	35	110	165	0.7	DNMG110408
C4-PDJNR/L-270 55-15HP	40	55	27	65	145	0.4	DNMG150608
C5-PDJNR/L-35060-1504HP	50	60	35	70	165	0.73	DNMG150608
C5-PDJNR/L-35060-15HP	50	60	35	65	165	0.7	DNMG150608
C6-PDJNR/L-45065-1504HP	63	65	45	95	195	1.2	DNMG150608
C6-PDJNR/L-45065-15HP	63	65	45	95	195	1.1	DNMG150608
C6-PDMNR/L-00130-15HP	63	130	0.6	--	--	1.7	DNMG150608

DDMNR/L

DVMNR/L

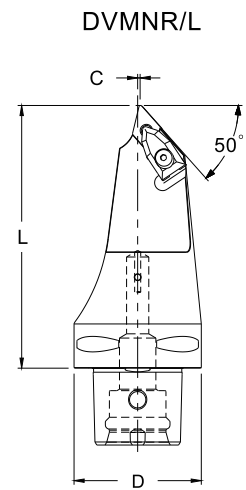
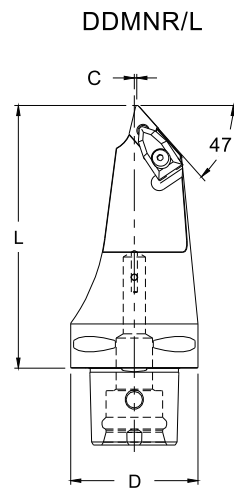

外徑刀具  
Turning Holder

訂貨型號 Order Code	D	L	C	Kg	刀片型號 Insert Type
C5-DDMNL-00115-15	50	115	1	1.08	DNMG150608
C6-DDMNL-00130-15	63	130	1	1.69	DNMG150608
C6-DDMNL-00130-1504	63	130	1	1.69	DNMG150408
C6-DDMNL-33120-15	63	120	33	2.3	DNMG150608
C6-DDMNL-33120-1504	63	120	33	2.3	DNMG150608

DDJNR/L

DDHNR/L

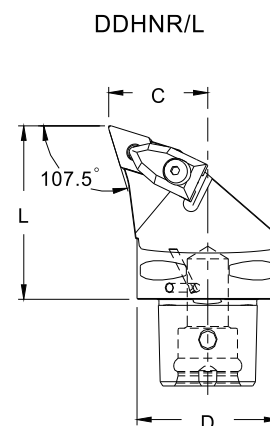
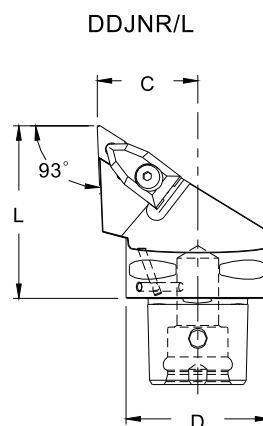
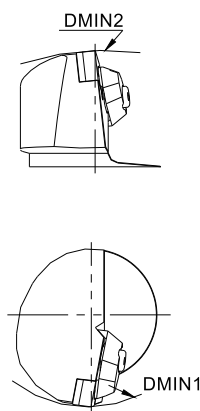

外徑刀具  
Turning Holder

訂貨型號 Order Code	D	L	C	DMIN1	DMIN2	Kg	刀片型號 Insert Type
C3-DDJNR/L-22045-11	32	45	22	60	121	0.22	DNMG110408
C4-DDJNR/L-27050-11	40	50	27	60	140	0.33	DNMG110408
C5-DDJNR/L-35060-11	50	60	35	65	165	0.7	DNMG110408
C6-DDJNR/L-45065-11	63	65	45	110	190	1.1	DNMG110408
C4-DDJNR/L-270 5515	40	55	27	110	145	0.46	DNMG150608
C4-DDJNR/L-27055-1504	40	55	27	110	145	0.46	DNMG150408
C5-DDJNR/L-35060-15	50	60	35	110	165	0.7	DNMG150608
C5-DDJNR/L-35060-1504	50	60	35	110	165	0.7	DNMG150408
C6-DDJNR/L-45065-15	63	65	45	110	190	1.1	DNMG150608
C6-DDJNR/L-45065-1504	63	65	45	110	190	1.1	DNMG150408
C4-DDHNR/L-27055-15	40	55	27	110	145	0.45	DNMG150608
C4-DDHNR/L-27055-1504	40	55	27	110	145	0.45	DNMG150408
C5-DDHNR/L-35060-15	50	60	35	110	165	0.7	DNMG150608
C5-DDHNR/L-35060-1504	50	60	35	110	165	0.7	DNMG150408
C6-DDHNR/L-45065-15	63	65	45	110	190	1.1	DNMG150608
C6-DDHNR/L-45065-1504	63	65	45	110	190	1.1	DNMG150408

DDNNN

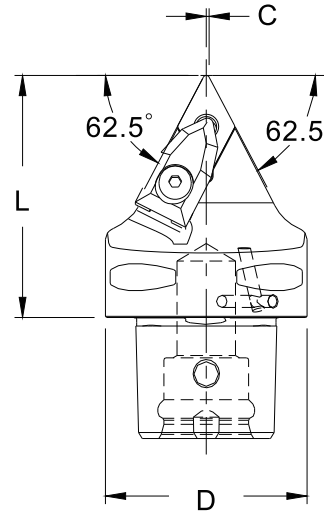

外徑刀具  
Turning Holder

訂貨型號 Order Code	D	L	C	Kg	刀片型號 Insert Type
C4-DDNNN-00050-11	40	50	0.5	0.33	DNMG110408
C5-DDNNN-00060-11	50	60	0.5	0.63	DNMG110408
C4-DDNNN-00055-15	40	55	0.5	0.33	DNMG150608
C4-DDNNN-00055-1504	40	55	0.5	0.33	DNMG150408
C5-DDNNN-00060-15	50	60	0.5	0.55	DNMG150608
C5-DDNNN-00060-1504	50	60	0.5	0.55	DNMG150408
C6-DDNNN-00065-15	63	65	0.5	1.1	DNMG150608
C6-DDNNN-00065-1504	63	65	0.5	1.1	DNMG150408

DDUNR/L

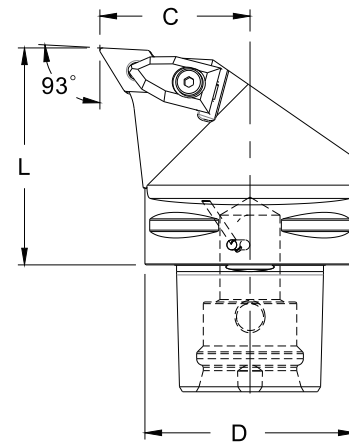
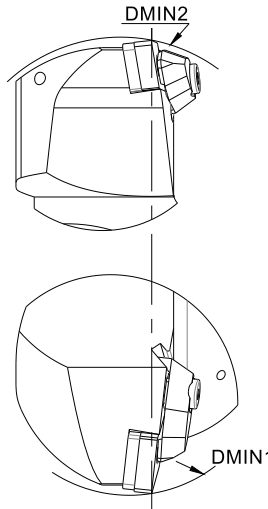

訂貨型號 Order Code	D	L	C	DMIN1	DMIN2	Kg	刀片型號 Insert Type
C4-DDUNR/L-27050-15	40	50	27	110	140	0.45	DNMG150608
C4-DDUNR/L-27050-1504	40	50	27	110	140	0.45	DNMG150408
C5-DDUNR/L-35060-15	50	60	35	110	165	0.7	DNMG150608
C5-DDUNR/L-35060-1504	50	60	35	110	165	0.7	DNMG150408
C6-DDUNR/L-45065-15	63	65	45	110	190	1.3	DNMG150608
C6-DDUNR/L-45065-1504	63	65	45	110	190	1.3	DNMG150408

**PDJNR/L**

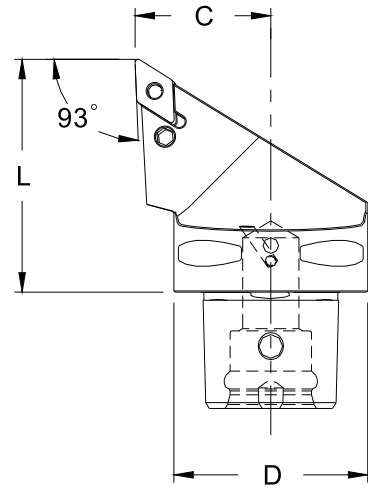
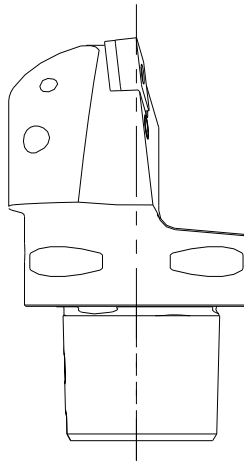

訂貨型號 Order Code	D	L	C	Kg	刀片型號 Insert Type
C3-PDJNR/L-22045-11	32	45	22	0.13	DNMG110408
C4-PDJNR/L-27050-11	40	50	27	0.49	DNMG110408
C5-PDJNR/L-35060-11	50	60	35	0.55	DNMG110408
C6-PDJNR/L-45065-11	63	65	45	1.1	DNMG110408
C4-PDJNR/L-27055-15	40	55	27	0.34	DNMG150608
C5-PDJNR/L-35060-15	50	60	35	0.55	DNMG150608
C6-PDJNR/L-45065-15	63	65	45	1.35	DNMG150608



DRSNR/L

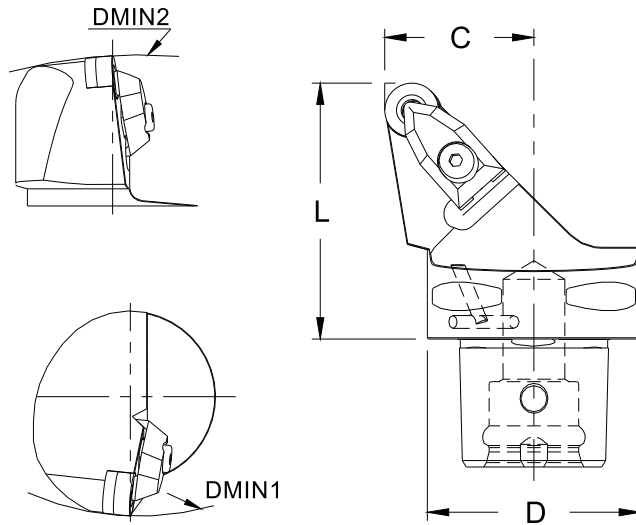

訂貨型號 Order Code	D	L	C	DMIN1	DMIN2	Kg	刀片型號 Insert Type
C4-DRSNR/L-27050-12	40	50	27	110	140	0.33	RNMG120400
C5-DRSNR/L-35060-12	50	60	35	110	165	0.7	RNMG120400
C6-DRSNR/L-45065-12	63	65	45	110	190	1.1	RNMG120400

**PRSCR/L**

**PRDCN**

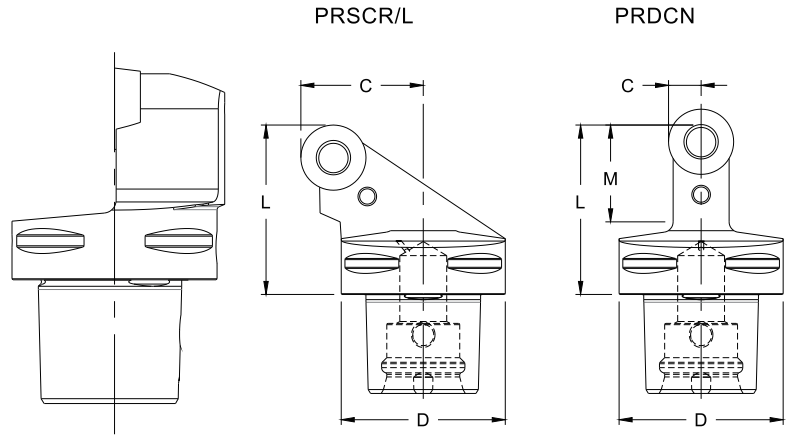

外徑刀具  
Turning Holder

訂貨型號 Order Code	D	L	C	M	Kg	刀片型號 Insert Type
C6-PRSCR/L-45065-25	63	65	45	--	1.3	RCMX250700
C6-PRDCN-00065-25A	63	65	12.5	40	0.9	RCMX250700

PSSNR/L-HP

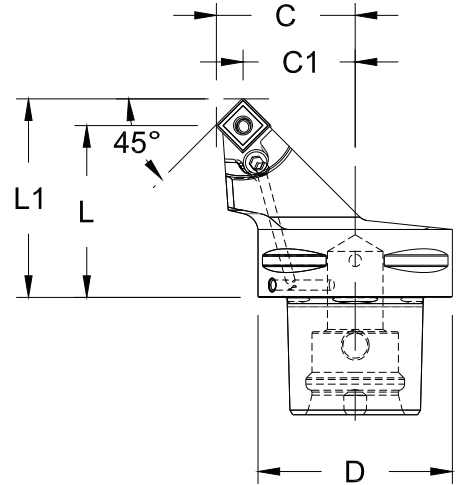
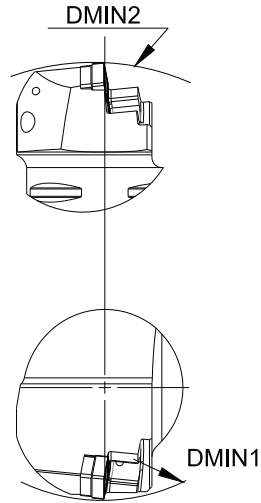

訂貨型號 Order Code	D	L	L1	C	C1	DMIN1	DMIN2	Kg	刀片型號 Insert Type
C4-PSSNR/L-27042-12HP	40	42	50.3	27	18.7	90	145	0.3	SNMG120408
C5-PSSNR/L-35052-12HP	50	52	60.3	35	26.7	110	165	0.7	SNMG120408
C6-PSSNR/L-45056-12HP	63	56	64.3	45	36.7	10	200	1.1	SNMG120408
C5-PSSNR/L-35052-15HP	50	50	60.2	35	24.8	110	165	0.7	SNMG150612
C6-PSSNR/L-45056-15HP	63	54	64.2	45	34.8	110	200	1.1	SNMG150612
C6-PSSNR/L-45056-19HP	63	52	64.5	45	32.5	110	180	1.1	SNMG190612

**DSDNN**

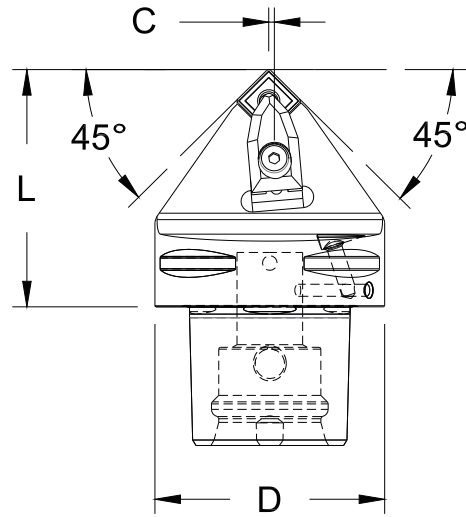

訂貨型號 Order Code	D	L	C	Kg	刀片型號 Insert Type
C3-DSDNN-00048-12	32	48	0.3	0.3	SNMG120408
C4-DSDNN-00050-12	40	50	0.3	0.4	SNMG120408
C5-DSDNN-00060-12	50	60	0.3	0.7	SNMG120408
C6-DSDNN-00065-12	63	65	0.3	1.33	SNMG120408
C5-DSDNN-00060-15	50	60	0.5	0.7	SNMG150608
C6-DSDNN-00065-15	63	65	0.5	1.1	SNMG150608
C5-DSDNN-00065-19	50	65	0.5	0.7	SNMG190612
C6-DSDNN-00070-19	63	70	0.5	1.1	SNMG190612

DSRNR/L

DSKNR/L

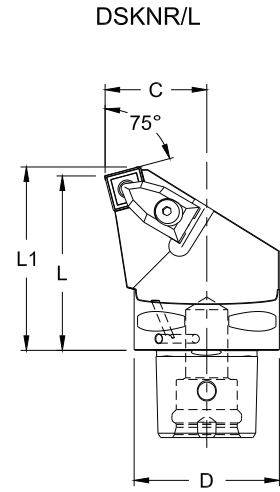
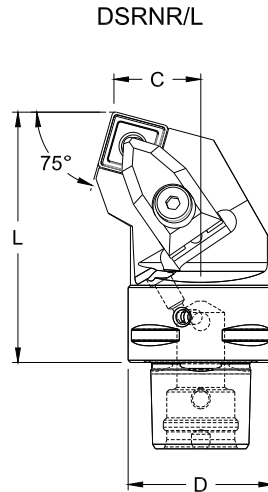
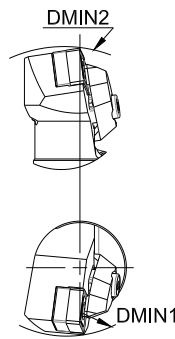

訂貨型號 Order Code	D	L	C	DMIN1	DMIN2	Kg	刀片型號 Insert Type
C3-DSRNR-19048-12	32	48	19	--	124	0.22	SNMG120408
C4-DSRNR/L-22050-12	40	50	20	--	140	0.42	SNMG120408
C5-DSRNR/L-27060-12	50	60	27	--	165	0.87	SNMG120408
C6-DSRNR/L-35065-12	63	65	35	--	190	1.33	SNMG120408
C5-DSRNR/L-27060-15	50	60	27	--	165	0.71	SNMG150612
C6-DSRNR/L-35065-15	63	65	35	--	190	1.33	SNMG150612
C5-DSRNR/L-27060-19	50	60	27	--	165	0.71	SNMG190612
C6-DSRNR/L-35065-19	63	65	35	--	190	1.33	SNMG190612
C3-DSKNR-22040-12	32	40	22	60	--	0.24	SNMG120408
C4-DSKNR/L-27050-12	40	50	27	110	--	0.46	SNMG120408
C5-DSKNR/L-35060-12	50	60	35	110	--	0.85	SNMG120408
C6-DSKNR/L-45065-12	63	65	45	110	--	1.32	SNMG120408
C5-DSKNR/L-35060-15	50	60	35	125	--	0.85	SNMG150612
C6-DSKNR/L-45065-15	63	65	45	125	--	1.32	SNMG150612
C5-DSKNR/L-35060-19	50	60	35	125	--	0.72	SNMG190612
C6-DSKNR/L-45065-19	63	65	45	125	--	1.32	SNMG190612

DSSNR/L

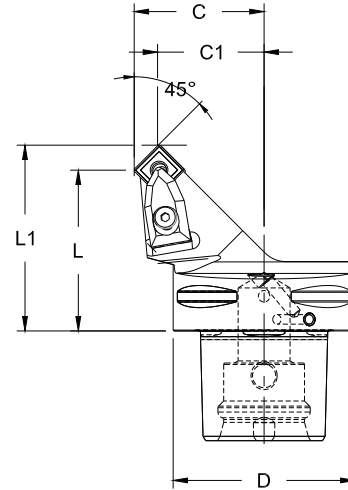
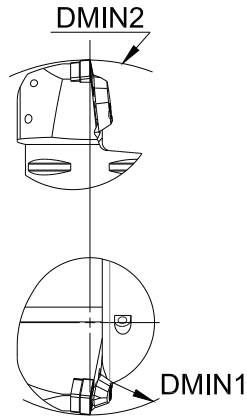

訂貨型號 Order Code	D	L	L1	C	C1	DMIN1	DMIN2	Kg	刀片型號 Insert Type
C3-DSSNR-22040-12	32	40	48.3	22	13.7	60	124	0.25	SNMG120408
C4-DSSNR/L-27042-12	40	42	50.3	27	18.7	110	140	0.33	SNMG120408
C5-DSSNR/L-35052-12	50	52	60.3	35	26.7	110	165	0.66	SNMG120408
C6-DSSNR/L-45056-12	63	56	64.3	45	36.7	110	190	1.09	SNMG120408
C4-DSSNR/L-27045-15	40	45	55.2	27	16.8	125	145	0.26	SNMG150612
C5-DSSNR/L-35050-15	50	50	60.2	35	24.8	125	165	0.7	SNMG150612
C6-DSSNR/L-45054-15	63	54	64.2	45	34.8	125	190	1.09	SNMG150612
C5-DSSNR/L-35048-19	50	48	60.5	35	22.5	125	165	0.71	SNMG190612
C6-DSSNR/L-45052-19	63	52	64.5	45	32.5	125	190	1.09	SNMG190612

**PSKNR/L**

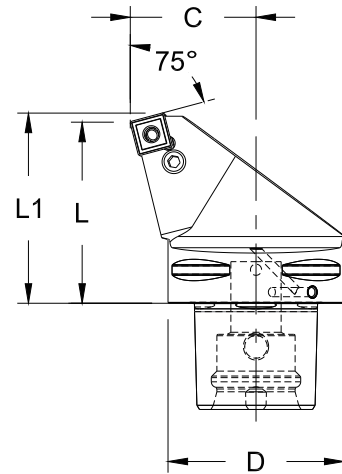
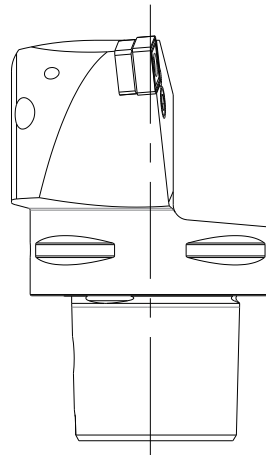

外徑刀具  
Turning Holder

訂貨型號 Order Code	D	L	C	L1	Kg	刀片型號 Insert Type
C4-PSKNR/L-27050-12	40	50	27	53.1	0.51	SNMG120408
C5-PSKNR/L-35060-12	50	60	35	63.1	0.86	SNMG120408
C6-PSKNR/L-45065-12	63	65	45	68.1	1.7	SNMG120408
C4-PSKNR/L-27050-15	40	50	27	54.8	0.33	SNMG150612
C5-PSKNR/L-35060-15	50	60	35	63.8	0.86	SNMG150612
C6-PSKNR/L-45065-15	63	65	45	68.8	1.7	SNMG150612
C5-PSKNR/L-35060-19	50	60	35	64.6	0.86	SNMG190612
C6-PSKNR/L-45065-19	63	65	45	69.6	1.34	SNMG190612

**PSRNR/L**

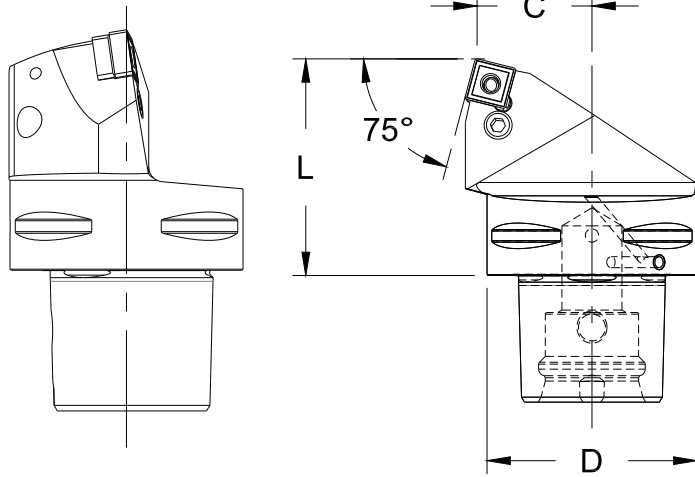

訂貨型號 Order Code	D	L	C	Kg	刀片型號 Insert Type
C4-PSRNR/L-22050-12	40	50	22	0.45	SNMG120408
C5-PSRNR/L-27060-12	50	60	27	0.87	SNMG120408
C6-PSRNR/L-35065-12	63	65	35	1.34	SNMG120408
C4-PSRNR/L-22050-15	40	50	22	0.42	SNMG150612
C5-PSRNR/L-27060-15	50	60	27	0.86	SNMG150612
C6-PSRNR/L-35065-15	63	65	35	1.34	SNMG150612
C5-PSRNR/L-27060-19	50	60	27	0.86	SNMG190612
C6-PSRNR/L-35065-19	63	65	35	1.34	SNMG190612



**PSSNR/L**

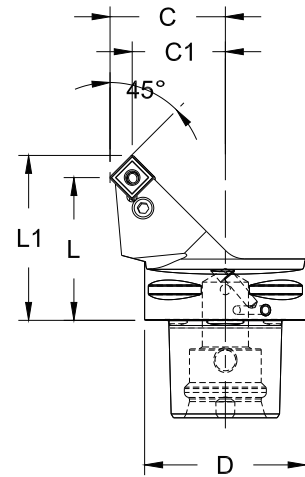
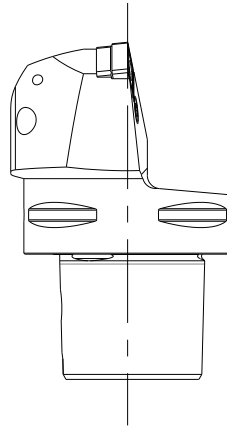

外徑刀具  
Turning Holder

訂貨型號 Order Code	D	L	L1	C	C1	Kg	刀片型號 Insert Type
C3-PSSNR-22032-12	32	32	40.3	22	13.7	0.21	SNMG120408
C4-PSSNR/L-27042-12	40	42	50.3	27	18.7	0.33	SNMG120408
C5-PSSNR/L-35052-12	50	52	60.3	35	26.7	0.7	SNMG120408
C6-PSSNR/L-45056-12	63	56	64.3	45	36.7	1.1	SNMG120408
C4-PSSNR/L-27040-15	40	40	50.2	27	16.8	0.33	SNMG150612
C5-PSSNR/L-35050-15	50	50	60.2	35	24.8	0.55	SNMG150612
C6-PSSNR/L-45054-15	63	54	64.2	45	34.8	1.1	SNMG150612
C5-PSSNR/L-35048-19	50	48	60.5	35	22.5	0.55	SNMG190612
C6-PSSNR/L-45052-19	63	52	64.5	45	32.5	1.1	SNMG190612

**PSDNN**

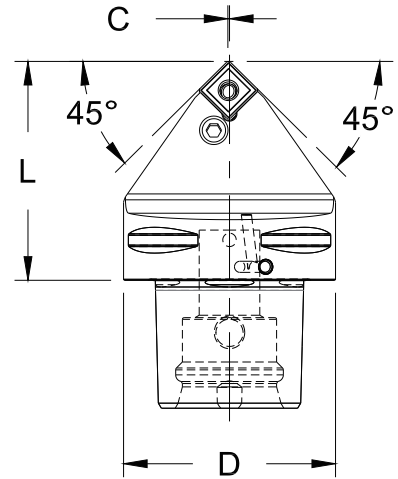
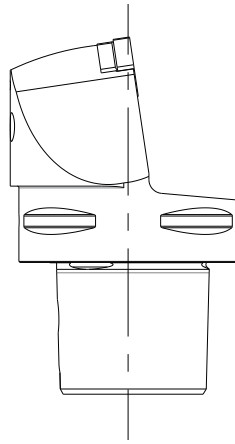

訂貨型號 Order Code	D	L	C	Kg	刀片型號 Insert Type
C4-PSDNN-00050-12	40	50	0.3	0.33	SNMG120408
C5-PSDNN-00060-12	50	60	0.3	0.71	SNMG120408
C6-PSDNN-00065-12	63	65	0.3	1.35	SNMG120408
C4-PSDNN-00050-15	40	50	0.5	0.33	SNMG150612
C5-PSDNN-00060-15	50	60	0.5	0.71	SNMG150612
C6-PSDNN-00065-15	63	65	0.5	1.1	SNMG150612
C5-PSDNN-00060-19	50	60	0.5	0.71	SNMG190612
C6-PSDNN-00065-19	63	65	0.5	1.1	SNMG190612
C6-PSDNN-00065-25	63	65	1	1.1	SNMG250724

DTGNR/L

DTJNR/L

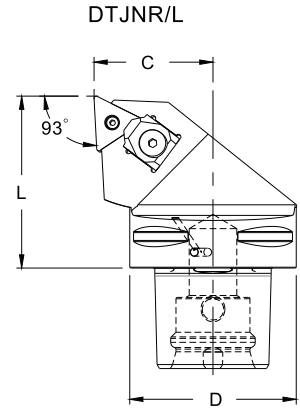
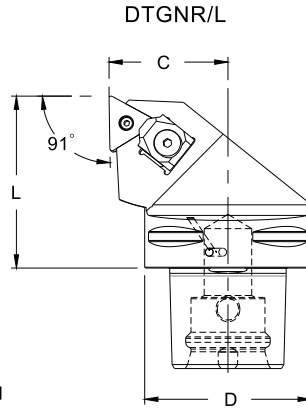
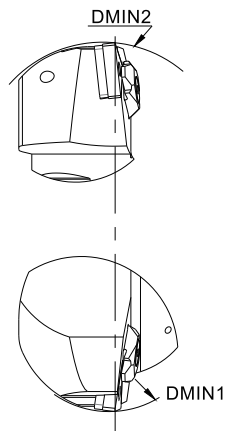

外徑刀具  
Turning Holder

訂貨型號 Order Code	D	L	C	DMIN1	DMIN2	Kg	刀片型號 Insert Type
C4-DTGNR/L-27050-16	40	50	27	110	140	0.55	TNMG160408
C5-DTGNL-35060-16	50	60	35	110	165	0.7	TNMG160408
C6-DTGNR/L-45065-16	63	65	45	110	190	1.3	TNMG160408
C4-DTGNR/L-27050-22	40	50	27	110	140	0.47	TNMG220408
C5-DTGNL-35060-22	50	60	35	110	165	0.84	TNMG220408
C6-DTGNR/L-45065-22	63	65	45	110	190	1.3	TNMG220408
C3-DTJNR/L-22040-16	32	40	22	60	116	0.22	TNMG160408
C4-DTJNR/L-27050-16	40	50	27	110	140	0.55	TNMG160408
C5-DTJNR/L-35060-16	50	60	35	110	165	0.7	TNMG160408
C6-DTJNR/L-45065-16	63	65	45	110	190	1.31	TNMG160408
C4-DTJNR/L-27050-22	40	50	27	110	140	0.55	TNMG220408
C5-DTJNR/L-35060-22	50	60	35	110	165	0.84	TNMG220408
C6-DTJNR/L-45065-22	63	65	45	110	190	1.31	TNMG220408
C6-DTJNR/L-45065-27	63	65	45	110	190	1.31	TNMG270612

DTTNR/L

DTFNR/L

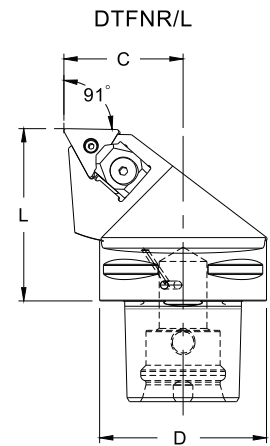
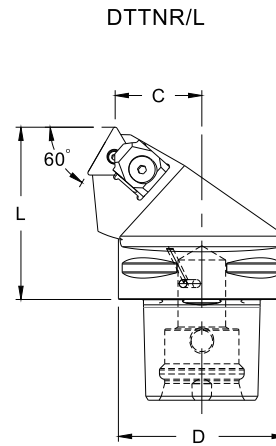
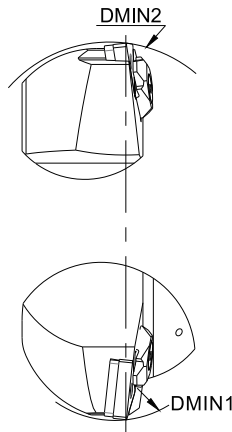

訂貨型號 Order Code	D	L	C	DMIN1	DMIN2	Kg	刀片型號 Insert Type
C4-DTTNR/L-22050-16	40	50	22	--	140	0.34	TNMG160408
C5-DTTNL-27060-16	50	60	27	--	165	0.7	TNMG160408
C5-DTTNR/L-27060-22	50	60	27	--	165	0.7	TNMG220408
C6-DTTNR/L-35065-22	63	65	35	--	190	1.1	TNMG220408
C3-DTFNL-22040-16	32	40	22	60	116	0.22	TNMG160408
C4-DTFNR/L-27050-16	40	50	27	110	140	0.42	TNMG160408
C5-DTFNR/L-35060-16	50	60	35	110	165	0.7	TNMG160408
C6-DTFNR/L-45065-16	63	65	45	110	190	1.3	TNMG160408
C4-DTFNR/L-27050-22	40	50	27	110	140	0.55	TNMG220408
C5-DTFNR/L-35060-22	50	60	35	110	165	0.84	TNMG220408
C6-DTFNR/L-45065-22	63	65	45	110	190	1.3	TNMG220408

MTJNR/L

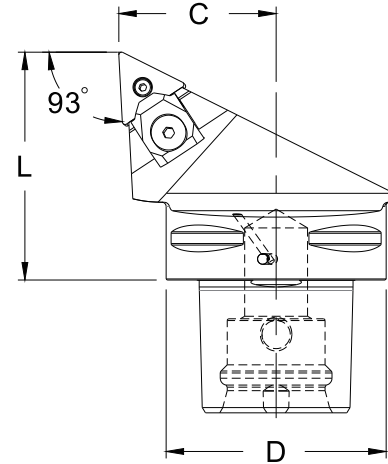
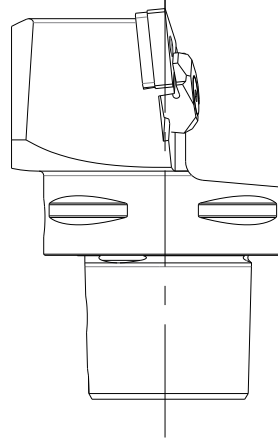

訂貨型號 Order Code	D	L	C	Kg	刀片型號 Insert Type
C3-MTJNR/L-22040-16	32	40	22	0.22	TNMG160408
C4-MTJNR/L-27050-16	40	50	27	0.42	TNMG160408
C5-MTJNR/L-35060-16	50	60	35	0.85	TNMG160408
C4-MTJNR/L-27050-22	40	50	27	0.42	TNMG220408
C5-MTJNR/L-35060-22	50	60	35	0.89	TNMG220408
C6-MTJNR/L-45065-22	63	65	45	1.3	TNMG220408
C6-MTJNR/L-45065-27	63	65	45	1.3	TNMG270612

**DVJNR/L**

**DVVNN**

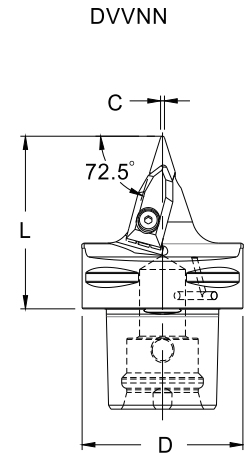
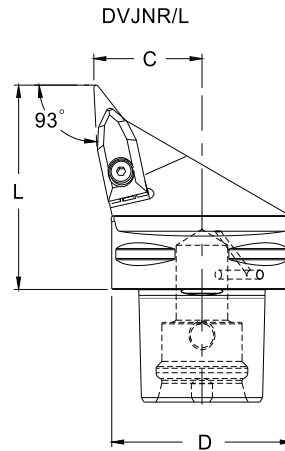
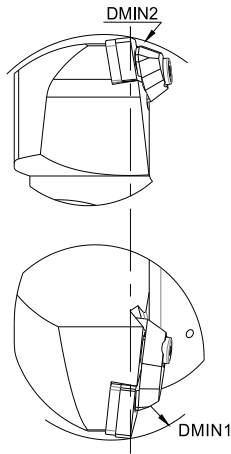

訂貨型號 Order Code	D	L	C	DMIN1	DMIN2	Kg	刀片型號 Insert Type
C4-DVJNR/L-27062-16	40	62	27	60	152	0.5	VNMG160408
C5-DVJNR/L-35065-16	50	65	35	65	170	0.7	VNMG160408
C6-DVJNR/L-45065-16	63	65	45	81	190	1.3	VNMG160408
C4-DVVNN-00062-16	40	62	0.6	--	152	0.34	VNMG160408
C5-DVVNN-00065-16	50	65	0.6	--	170	0.46	VNMG160408
C6-DVVNN-00065-16	63	65	0.6	--	190	0.9	VNMG160408

MVJNR/L

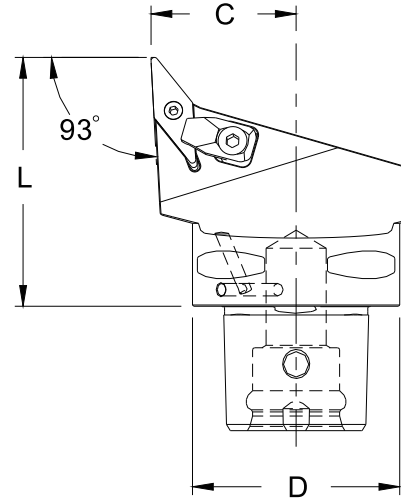
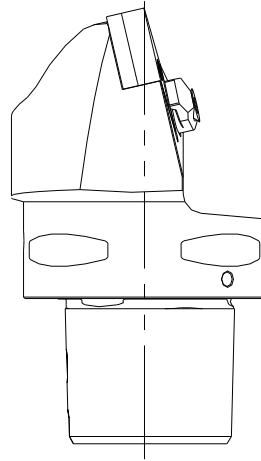

訂貨型號 Order Code	D	L	C	Kg	刀片型號 Insert Type
C3-MVJNR/L-22045-16	32	45	22	0.22	VNMG160408
C4-MVJNR/L-27050-16	40	50	27	0.66	VNMG160408
C5-MVJNR/L-35060-16	50	60	35	0.85	VNMG160408

DWLNR/L

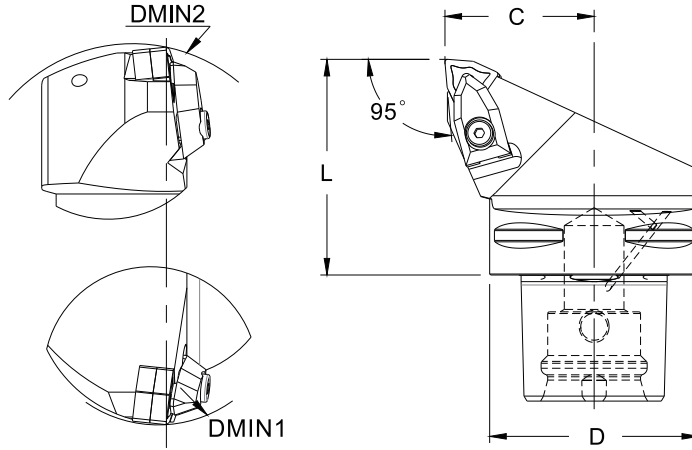

外徑刀具  
Turning Holder

訂貨型號 Order Code	D	L	C	DMIN1	DMIN2	Kg	刀片型號 Insert Type
C3-DWLNR/L-22040-06	32	40	22	60	116	0.21	WNMG060408
C4-DWLNR/L-27050-06	40	50	27	60	140	0.42	WNMG060408
C5-DWLNR/L-35060-06	50	60	35	65	165	0.7	WNMG060408
C6-DWLNR/L-45065-06	63	65	45	81	190	1.3	WNMG060408
C4-DWLNR/L-27050-08	40	50	27	110	140	0.42	WNMG080408
C5-DWLNR/L-35060-08	50	60	35	110	165	0.7	WNMG080408
C6-DWLNR/L-45065-08	63	65	45	110	190	1.3	WNMG080408



MWLNR/L

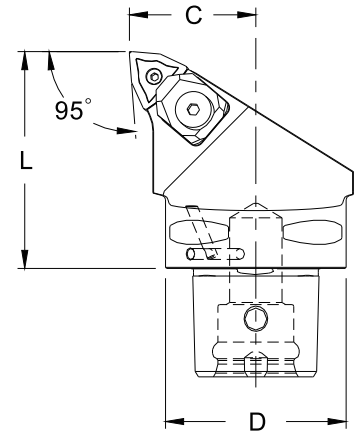
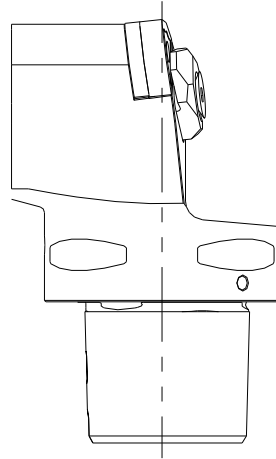

訂貨型號 Order Code	D	L	C	Kg	刀片型號 Insert Type
C3-MWLNR/L-22040-06	32	40	22	0.22	WNMG060408
C4-MWLNR/L-27050-06	40	50	27	0.42	WNMG060408
C4-MWLNR/L-27050-08	40	50	27	0.31	WNMG080408
C5-MWLNR/L-35060-08	50	60	35	0.85	WNMG080408

SCLCR/L-HPA

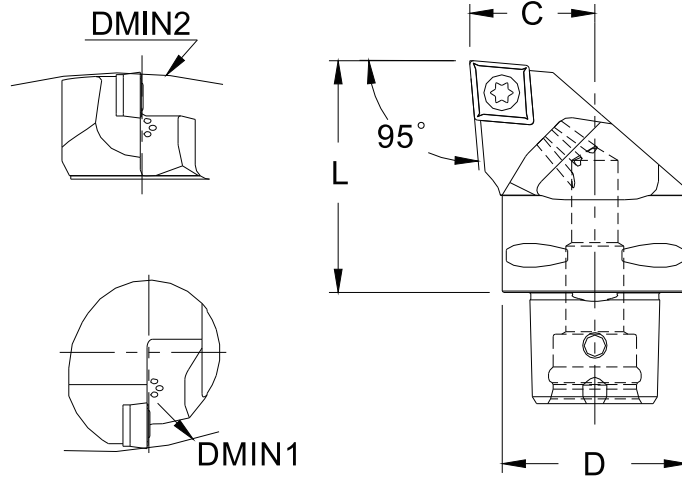

訂貨型號 Order Code	D	L	C	DMIN1	DMIN2	Kg	刀片型號 Insert Type
C3-SCLCR/L-22040-09HPA	32	40	22	130	116	0.19	CCMT09T308
C4-SCLCR/L-27050-09HPA	40	50	27	130	140	0.38	CCMT09T308
C4-SCLCR/L-27050-12HPA	40	50	27	130	140	0.38	CCMT120408
C6-SCLCR/L-45065-12HPA	63	65	45	125	190	1.21	CCMT120408

SCLCR/L

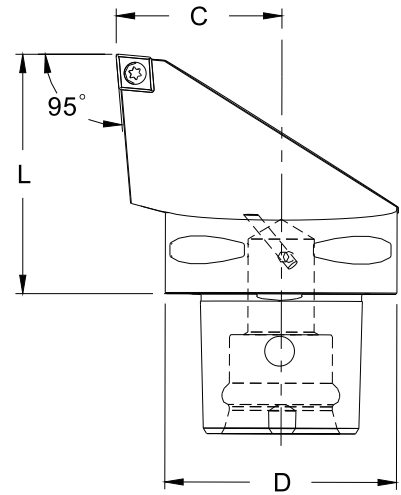
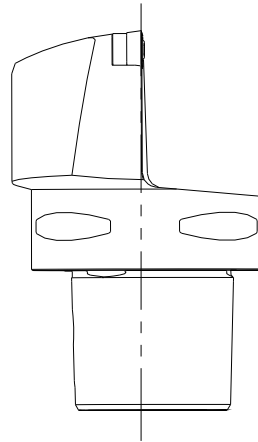

外徑刀具  
Turning Holder

訂貨型號 Order Code	D	L	C	Kg	刀片型號 Insert Type
C3-SCLCR/L-22040-09	32	40	22	0.13	CCMT09T308
C4-SCLCR/L-27050-09	40	50	27	0.34	CCMT09T308
C5-SCLCR/L-35060-09	50	60	35	0.64	CCMT09T308
C6-SCLCR/L-45065-09	63	65	45	1.1	CCMT09T308
C3-SCLCR/L-22040-12	32	40	22	0.13	CCMT120408
C4-SCLCR/L-27050-12	40	50	27	0.34	CCMT120408
C5-SCLCR/L-35060-12	50	60	35	0.64	CCMT120408
C6-SCLCR/L-45065-12	63	65	45	1.1	CCMT120408

**SCMCN**

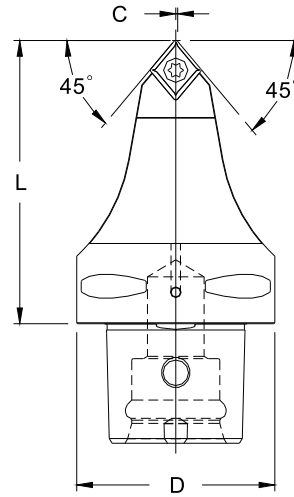

外徑刀具  
Turning Holder

訂貨型號 Order Code	D	L	C	Kg	刀片型號 Insert Type
C6-SCMCN-00090-12	63	90	0	1.3	CCMT120408

SDJCR/L-HPA

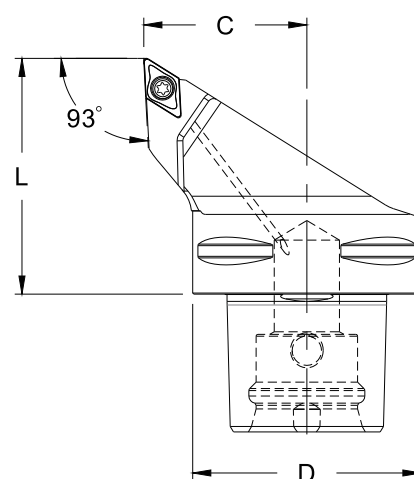
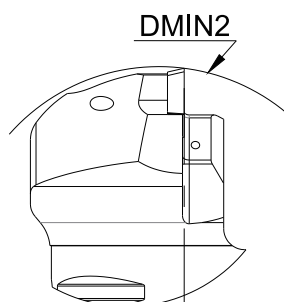

訂貨型號 Order Code	D	L	C	DMIN2	Kg	刀片型號 Insert Type
C3-SDJCR/L-22040-11HPA	32	40	22	116	0.19	DCMT11T308
C4-SDJCR/L-27050-11HPA	40	50	27	140	0.38	DCMT11T308
C5-SDJCR/L-35060-11HPA	50	60	35	165	0.7	DCMT11T308
C6-SDJCR/L-45065-11HPA	63	65	45	190	1.21	DCMT11T308

SDNCN

SDJCR/L

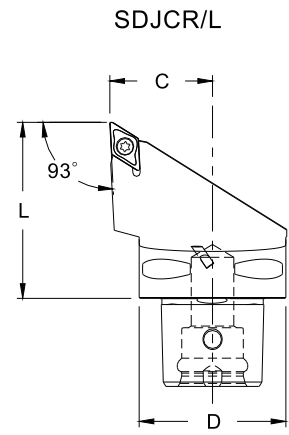
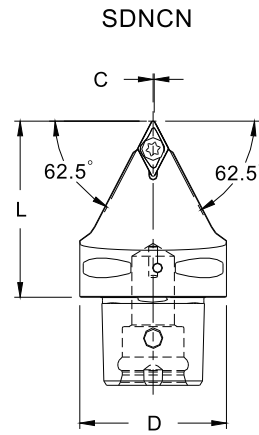
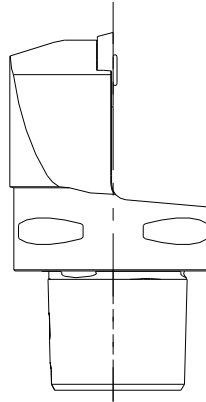

訂貨型號 Order Code	D	L	C	Kg	刀片型號 Insert Type
C3-SDNCN-00040-11	32	40	0.5	0.13	DCMT11T308
C4-SDNCN-00050-11	40	50	0.5	0.45	DCMT11T308
C5-SDNCN-00060-11	50	60	0.5	0.58	DCMT11T308
C3-SDJCR-22040-07	32	40	22	0.13	DCMT070204
C4-SDJCR-27050-07	40	50	27	0.34	DCMT070204
C3-SDJCR/L-22040-11	32	40	22	0.13	DCMT11T308
C4-SDJCR/L-27050-11	40	50	27	0.34	DCMT11T308
C5-SDJCR/L-35060-11	50	60	35	0.62	DCMT11T308
C6-SDJCR/L-45065-11	63	65	45	1.1	DCMT11T308

SRSCR/L-HP

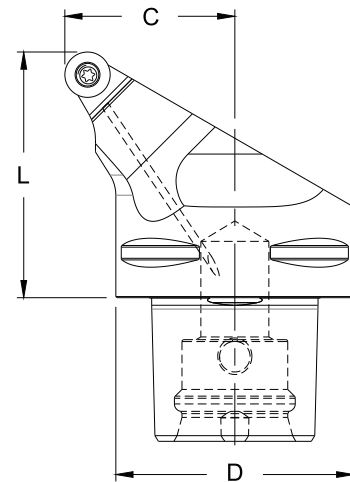
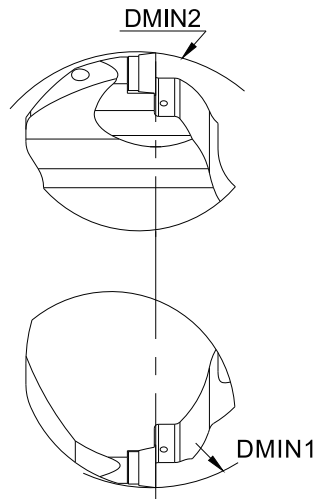

訂貨型號 Order Code	D	L	C	DMIN1	DMIN2	Kg	刀片型號 Insert Type
C5-SRSCR/L-35060-10HP	50	60	35	130	270	0.7	RCMT10T3M0
C6-SRSCR/L-45065-10HP	63	65	45	140	300	1.21	RCMT10T3M0
C5-SRSCR/L-35060-12HP	50	60	35	130	270	0.7	RCMT1204M0
C6-SRSCR/L-45065-12HP	63	65	45	120	195	1.1	RCMT1204M0

SRDCN-HPA

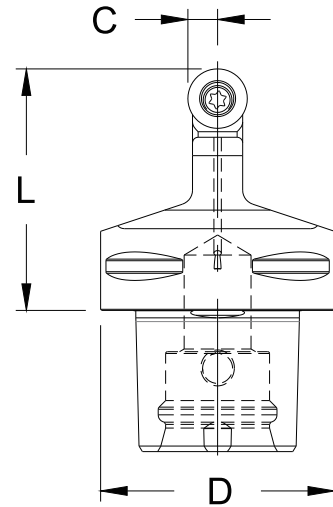
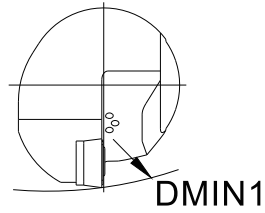

訂貨型號 Order Code	D	L	C	DMIN1	Kg	刀片型號 Insert Type
C5-SRDCN-00060-10AHPA	50	60	5	80	0.7	RCMT10T3M0
C4-SRDCN-00050-12AHPA	40	50	6	80	0.38	RCMT1204M0
C5-SRDCN-00060-12AHPA	50	60	6	80	0.7	RCMT1204M0
C6-SRDCN-00065-12AHPA	63	65	6	80	1.21	RCMT1204M0
C6-SRDCN-00065-16AHPA	63	65	8	80	1.21	RCMT1606M0



SRSCR/L-HPA

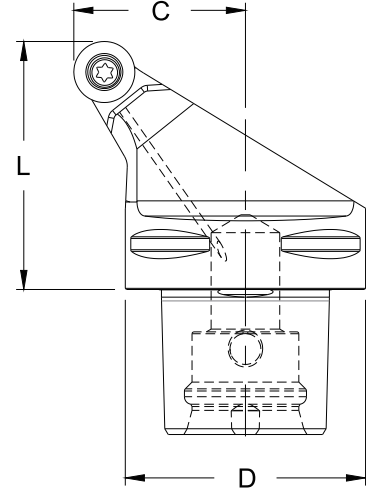
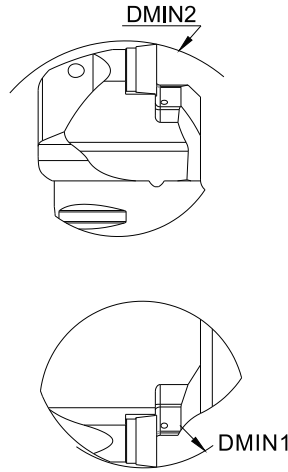

訂貨型號 Order Code	D	L	C	DMIN1	DMIN2	Kg	刀片型號 Insert Type
C5-SRSCR/L-35060-12HPA	50	60	35	150	165	0.7	RCMT1204M0
C6-SRSCR/L-45065-12HPA	63	65	45	150	190	1.21	RCMT1204M0
C5-SRSCR/L-35060-16HPA	50	60	35	175	165	0.7	RCMT1606M0
C6-SRSCR/L-45065-16HPA	63	65	45	175	190	1.21	RCMT1606M0

**SRDCN**

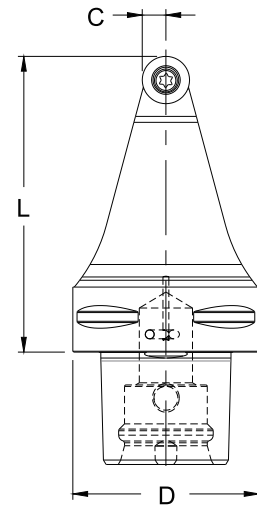
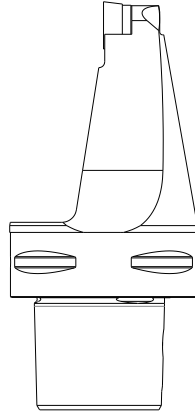

訂貨型號 Order Code	D	L	C	Kg	刀片型號 Insert Type
C6-SRDCN-00100-10	63	100	5	1.35	RCMT10T3M0
C6-SRDCN-00100-16	63	100	8	1.35	RCMT1606M0

SRDCN-A

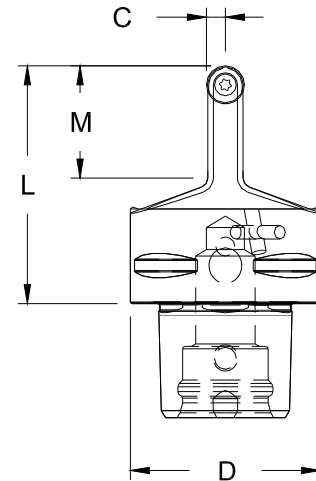
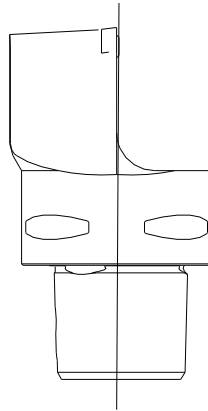

外徑刀具  
Turning Holder

訂貨型號 Order Code	D	L	C	M	Kg	刀片型號 Insert Type
C4-SRDCN-00050-06A	40	50	3	12	0.34	RCMT0602M0
C5-SRDCN-00060-06A	50	60	3	12	0.7	RCMT0602M0
C4-SRDCN-00050-08A	40	50	4	16	0.28	RCMT0803M0
C5-SRDCN-00060-08A	50	60	4	16	0.68	RCMT0803M0
C4-SRDCN-00050-10A	40	50	5	25	0.33	RCMT10T3M0
C5-SRDCN-00060-10A	50	60	5	25	0.61	RCMT10T3M0
C6-SRDCN-00065-10A	63	65	5	25	1.1	RCMT10T3M0
C4-SRDCN-00050-12A	40	50	6	28	0.33	RCMT1204M0
C5-SRDCN-00060-12A	50	60	6	28	0.62	RCMT1204M0
C6-SRDCN-00065-12A	63	65	6	28	1.1	RCMT1204M0
C5-SRDCN-00060-16A	50	60	8	35	0.58	RCMT1606M0
C6-SRDCN-00065-16A	63	65	8	35	0.9	RCMT1606M0
C5-SRDCN-00060-20A	50	60	10	35	0.62	RCMT2006M0
C6-SRDCN-00065-20A	63	65	10	40	0.9	RCMT2006M0

SRSCR/L

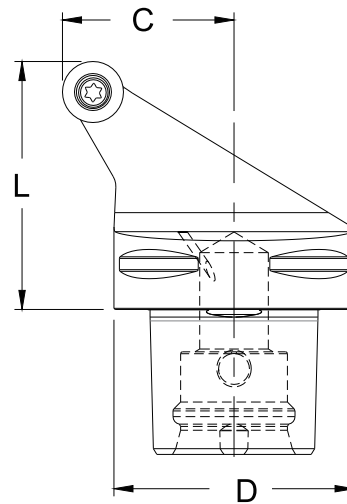

訂貨型號 Order Code	D	L	C	Kg	刀片型號 Insert Type
C4-SRSCR-27050-06	40	50	27	0.33	RCMT0602M0
C5-SRSCR/L-35060-06	50	60	35	0.7	RCMT0602M0
C4-SRSCR/L-27050-08	40	50	27	0.33	RCMT0803M0
C5-SRSCR/L-35060-08	50	60	35	0.7	RCMT0803M0
C3-SRSCR-22040-10	32	40	22	0.22	RCMT10T3M0
C4-SRSCR/L-27050-10	40	50	27	0.33	RCMT10T3M0
C5-SRSCR/L-35060-10	50	60	35	0.7	RCMT10T3M0
C6-SRSCR/L-45065-10	63	65	45	1.1	RCMT10T3M0
C4-SRSCR/L-27050-12	40	50	27	0.4	RCMT1204M0
C5-SRSCR/L-35060-12	50	60	35	0.7	RCMT1204M0
C6-SRSCR/L-45065-12	63	65	45	1.1	RCMT1204M0
C5-SRSCR/L-35060-16	50	60	35	0.7	RCMT1606M0
C6-SRSCR/L-45065-16	63	65	45	1.1	RCMT1606M0
C5-SRSCR/L-35060-20	50	60	35	0.86	RCMT2006M0
C6-SRSCR/L-45065-20	63	65	45	1.35	RCMT2006M0

STJCR/L

STGCR/L

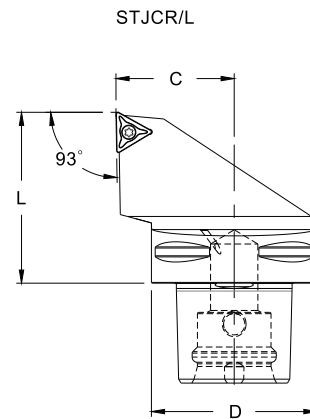
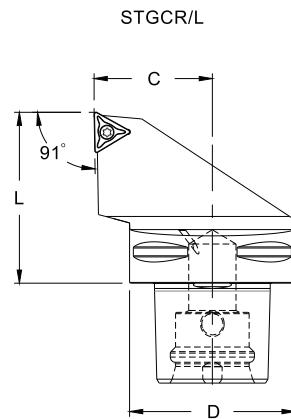
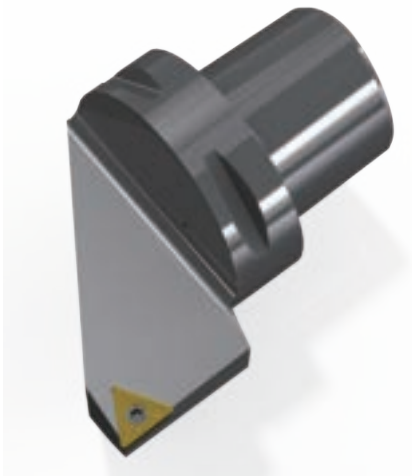

訂貨型號 Order Code	D	L	C	Kg	刀片型號 Insert Type
C4-STJCR-27050-11-B1	40	50	27	0.34	TCMT110304
C4-STGCR-27050-16	40	50	27	0.34	TCMT16T308
C4-STJCR-27050-16	40	50	27	0.34	TCMT16T308
C5-STGCR/L-35060-16	50	60	35	0.64	TCMT16T308
C5-STJCR-35060-16	50	60	35	0.64	TCMT16T308
C6-STGCR/L-45065-16	63	65	45	1.1	TCMT16T308

SVJBR/L-HP

SVUBR/L-HP

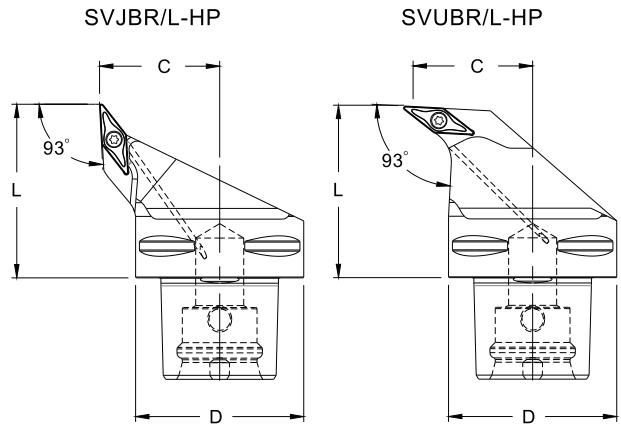
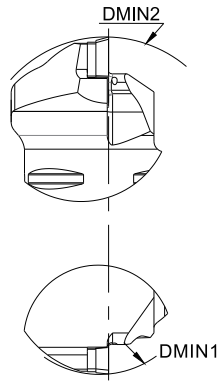

訂貨型號 Order Code	D	L	C	DMIN1	DMIN2	Kg	刀片型號 Insert Type
C4-SVJBR/L-27050-16HP	40	50	27	--	140	0.3	VBMT160408
C5-SVJBR/L-35060-16HP	50	60	35	--	200	0.7	VBMT160408
C6-SVJBR/L-45065-16HP	63	65	45	--	200	1.3	VBMT160408
C6-SVUBR/L-45065-16HP	63	65	45	85	--	1.3	VBMT160408

SVHBR/L-HPA

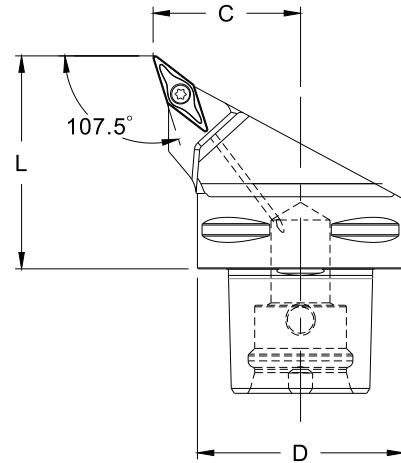
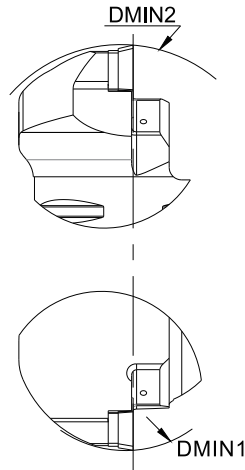

訂貨型號 Order Code	D	L	C	DMIN2	Kg	刀片型號 Insert Type
C4-SVHBR/L-27050-16HPA	40	50	27	140	0.38	VBMT160408
C5-SVHBR/L-35060-16HPA	50	60	35	165	0.7	VBMT160408
C6-SVHBR/L-45065-16HPA	63	65	45	190	1.21	VBMT160408

SVJBR/L-HPAB

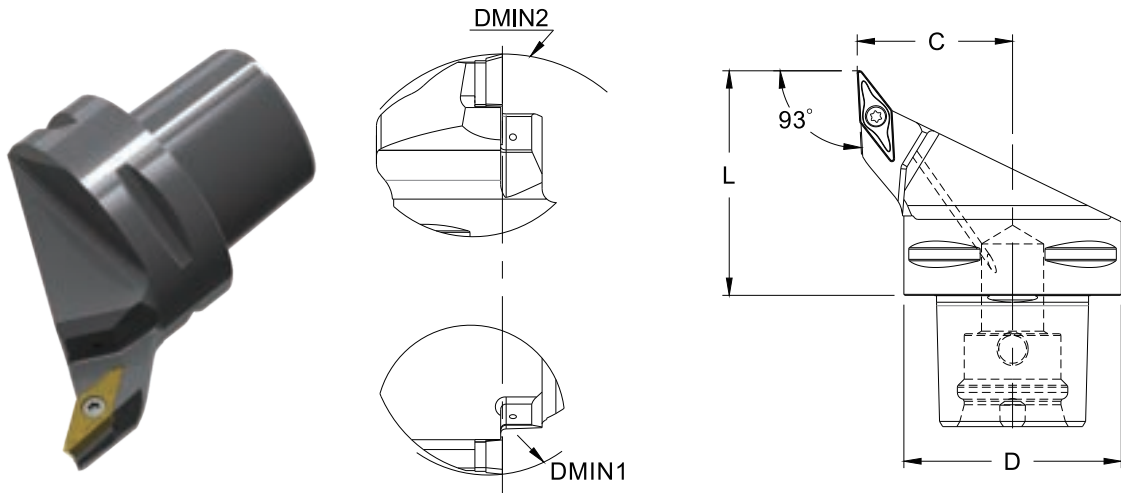

外徑刀具  
Turning Holder

訂貨型號 Order Code	D	L	C	DMIN2	Kg	刀片型號 Insert Type
C3-SVJBR/L-22040-11HPAB1	32	40	22	116	0.19	VBMT110304
C4-SVJBR/L-27050-11HPAB1	40	50	27	140	0.38	VBMT110304
C4-SVJBR/L-27050-16HPA	40	50	27	140	0.38	VBMT160408
C5-SVJBR/L-35060-16HPA	50	60	35	165	0.7	VBMT160408
C6-SVJBR/L-45065-16HPA	63	65	45	190	1.21	VBMT160408



SVHBR/L

SVJBR/L

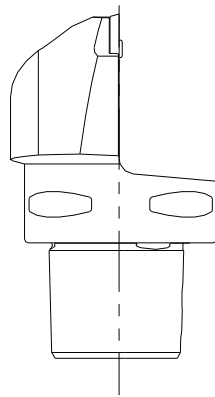

SVHBR/L

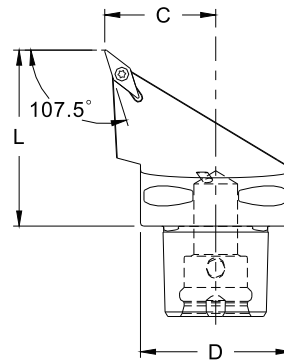

SVJBR/L

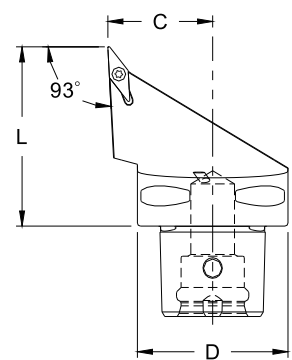

外徑刀具  
Turning Holder

訂貨型號 Order Code	D	L	C	Kg	刀片型號 Insert Type
C3-SVHBR/L-22040-11	32	40	22	0.13	VBMT110204
C3-SVHBR/L-22040-11-B1	32	40	22	0.13	VBMT110304
C4-SVHBR/L-27050-11	40	50	27	0.49	VBMT110204
C4-SVHBR/L-27050-11-B1	40	50	27	0.45	VBMT110304
C5-SVHBR/L-35060-11	50	60	35	0.71	VBMT110204
C4-SVHBR/L-27050-16	40	50	27	0.45	VBMT160408
C5-SVHBR/L-35060-16	50	60	35	0.58	VBMT160408
C6-SVHBR/L-45065-16	63	65	45	0.9	VBMT160408
C3-SVJBR/L-22040-11	32	40	22	0.13	VBMT110204
C3-SVJBR/L-22040-11-B1	32	40	22	0.13	VBMT110304
C4-SVJBR/L-27050-11	40	50	27	0.48	VBMT110204
C4-SVJBR/L-27050-11-B1	40	50	27	0.45	VBMT110304
C5-SVJBR/L-35060-11	50	60	35	0.71	VBMT110204
C4-SVJBR/L-27050-16	40	50	27	0.3	VBMT160408
C5-SVJBR/L-35060-16	50	60	35	0.58	VBMT160408
C6-SVJBR/L-45065-16	63	65	45	0.89	VBMT160408

SVVBN

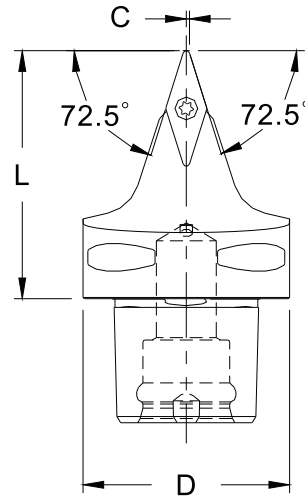

外徑刀具  
Turning Holder

訂貨型號 Order Code	D	L	C	Kg	刀片型號 Insert Type
C3-SVVBN-00040-11	32	40	0.3	0.13	VBMT110204
C3-SVVBN-00040-11-B1	32	40	0.3	0.13	VBMT110304
C4-SVVBN-00050-11	40	50	0.3	0.28	VBMT110204
C4-SVVBN-00050-11-B1	40	50	0.3	0.28	VBMT110304
C4-SVVBN-00050-16	40	50	0.6	0.28	VBMT160408
C5-SVVBN-00060-16	50	60	0.6	0.52	VBMT160408
C6-SVVBN-00065-16	63	65	0.6	0.89	VBMT160408

SVMBL

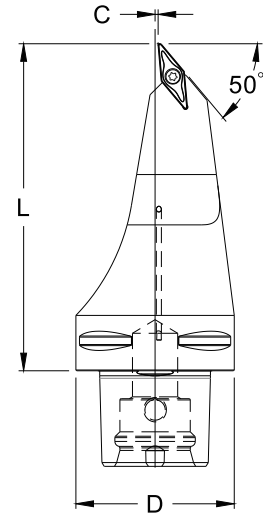
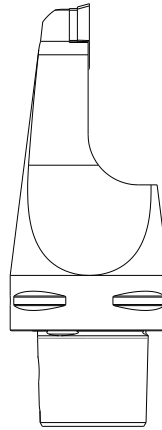

訂貨型號 Order Code	D	L	C	Kg	刀片型號 Insert Type
C5-SVMBL-00115-16	50	115	1.2	0.87	VBMT160408
C6-SVMBL-00130-16	63	130	1.2	1.69	VBMT160408
C6-SVMBL-33120-16	63	120	33	1.69	VBMT160408

SVSBR/L-HPA

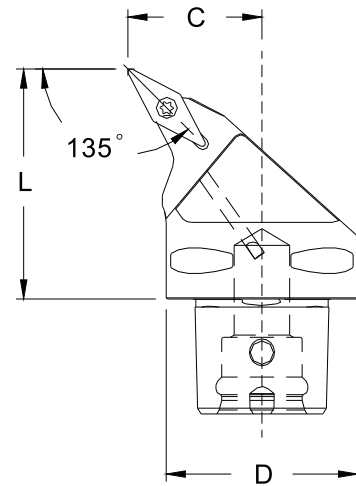
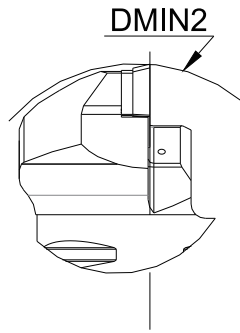

外徑刀具  
Turning Holder

訂貨型號 Order Code	D	L	C	DMIN2	Kg	刀片型號 Insert Type
C4-SVSBR/L-27050-16HPA	40	50	27	140	0.38	VBMT160408
C5-SVSBR/L-35060-16HPA	50	60	35	165	0.7	VBMT160408
C6-SVSBR/L-45065-16HPA	63	65	45	190	1.21	VBMT160408

R/LFA-E

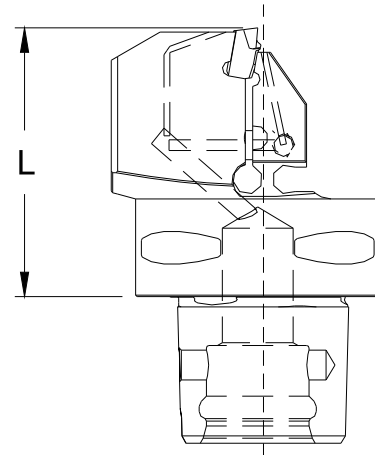
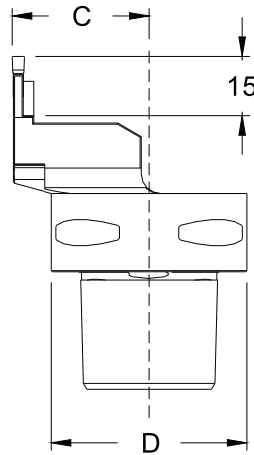

訂貨型號 Order Code	D	L	C	Kg	刀片型號 Insert Type
C3-R/LFA203015-22050E	32	50	22	0.3	A2030N00CM02
C3-R/LFA205015-22050E	32	50	22	0.3	A2050N00CM03
C4-R/LFA203015-27055E	40	55	27	0.4	A2030N00CM02
C4-R/LFA205015-27055E	40	55	27	0.4	A2050N00CM03
C5-R/LFA203015-35055E	50	55	35	0.6	A2030N00CM02
C5-R/LFA205015-35055E	50	55	35	0.6	A2050N00CM03
C6-R/LFA203015-45065E	63	65	45	1.2	A2030N00CM02
C6-R/LFA205015-45065E	63	65	45	1.2	A2050N00CM03

**SER/L**

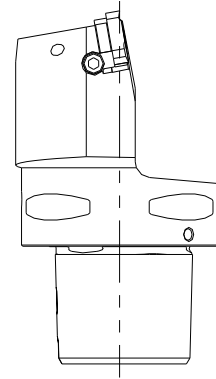
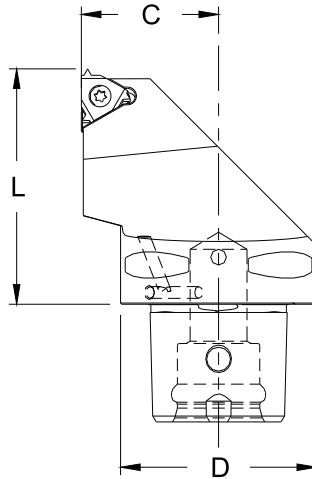

訂貨型號 Order Code	D	L	C	Kg	刀片型號 Insert Type
C3-SER/L-22040-16	32	40	22	0.3	16ER ISO
C4-SER/L-27050-16	40	50	27	0.5	16ER ISO
C5-SER/L-35060-16	50	60	35	0.5	16ER ISO
C6-SER/L-45065-16	63	65	45	0.5	16ER ISO

TR/LE-BMT

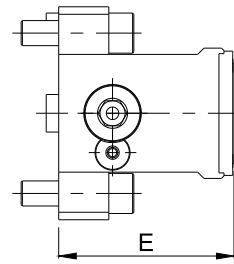
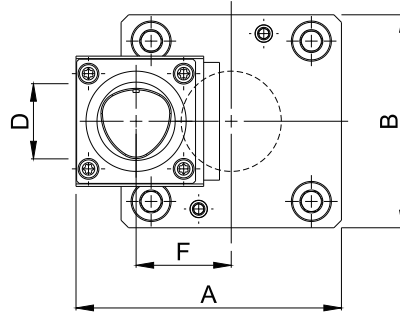
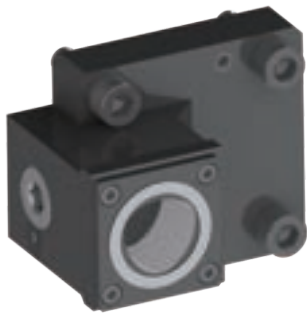

訂貨型號 Order Code	D	E	F	A	B	CP Bar/PSL	Nm	Kg
C4-TR/LE-BMT55-70	40	70	38	106	85	80	50	2.2
C4-TR/LE-BMT65-60	40	60	71	142	96	80	50	3.7
C5-TR/LE-BMT65-50	50	50	88	175	96	80	70	5.7

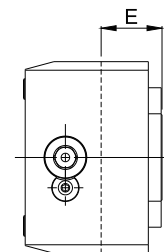
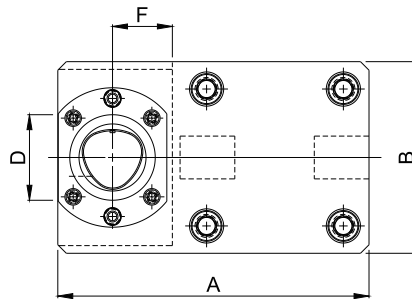

訂貨型號 Order Code	D	E	F	A	B	CP Bar/PSL	Nm	Kg
C5-TR/LE-BMT75-40	50	40	35	182	112	80	70	7
C6-TR/LE-BMT85-35	63	35	43	225	124	80	90	11.7

■ R:右手型 Right-hand type   
 ■ L:左手型 Left-hand type

TR/LI-BMT

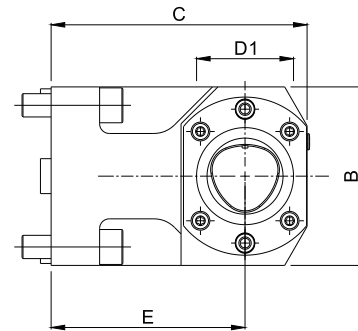
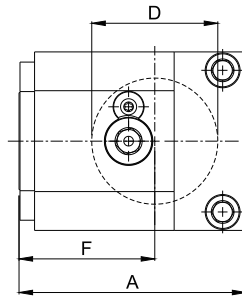

訂貨型號 Order Code	D	C	E	F	A	B	CP Bar/PSL	Nm	Kg
C4-TR/LI-BMT55-70	40	94	70	76	120	85	80	50	4.6
C4-TR/LI-BMT65-100	40	124	100	70	117	92	80	50	6.5
C5-TR/LI-BMT65-100	50	132	100	70	117	92	80	70	6.5

- R:右手型      ■ L:左手型
- Right-hand type      Left-hand type



TR/LI-BMT-S

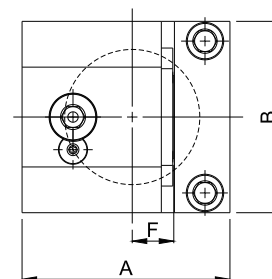
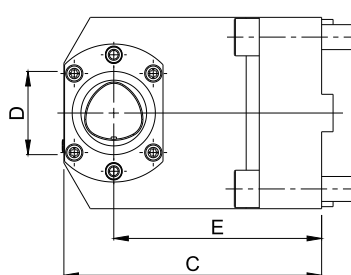

訂貨型號 Order Code	D	C	E	F	A	B	CP Bar/PSL	Nm	Kg
C4-TR/LI-BMT65-100-S	40	124	100	20	98	92	80	50	6.1

- R:右手型      ■ L:左手型
- Right-hand type      Left-hand type

TR/LE-BMT-DT

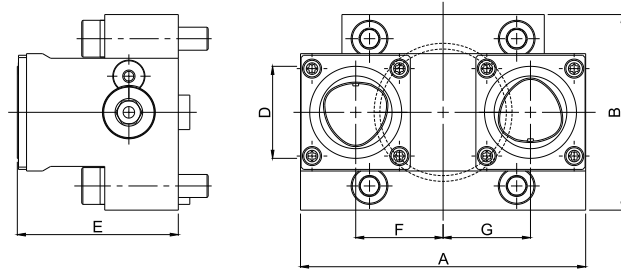

訂貨型號 Order Code	D	E	F	G	A	B	CP Bar/PSL	Nm	Kg
C4-TR/LE-BMT65-50-50-DT	40	80	50	50	148	96	80	50	7.6

- R:右手型      ● L:左手型
- Right-hand type      Left-hand type

TR/LE-BMT-TT

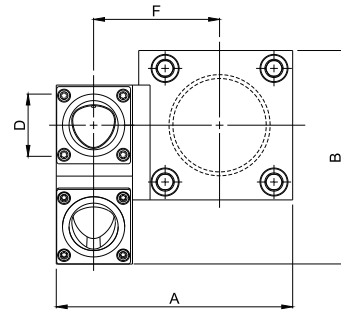
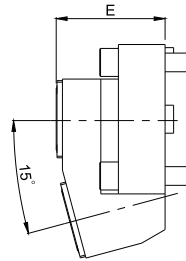

訂貨型號 Order Code	D	E	F	A	B	CP Bar/PSL	Nm	Kg
C4-TR/LE-BMT65-81-TT	40	70	81	152	137	80	50	4.7

- R:右手型      ■ L:左手型
- Right-hand type      Left-hand type

TR/LE-BMT-YT

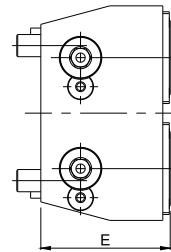
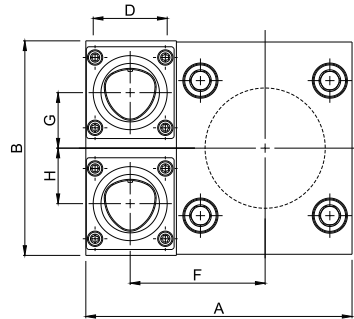

訂貨型號 Order Code	D	E	F	G	H	A	B	CP Bar/PSL	Nm	Kg
C4-TR/LE-BMT65-73-30-YT	40	70	73	30	30	144	116	80	50	5.2

- R:右手型      ● L:左手型
- Right-hand type      Left-hand type

DA-BMT

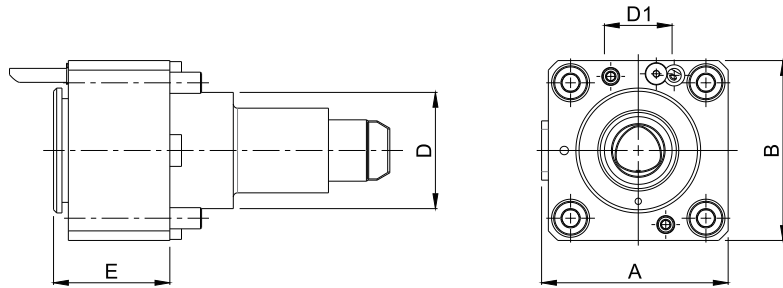

訂貨型號 Order Code	D	D1	E	F	A	B	Max R.P.M	CP Bar/PSL	Nm	Kg
C3-DA-BMT55-55-E	55	32	55	0	85	85	6000	80	25	3.2
C3-DA-BMT55-55-I	55	32	55	0	85	85	6000	80	25	3.2
C4-DA-BMT65-54-E	65	40	54	0	96	96	6000	80	40	4.2
C4-DA-BMT65-54-I	65	40	54	0	96	96	6000	80	40	4.3
C5-DA-BMT75-68-E	75	50	68	0	112	112	4000	80	60	6.8
C5-DA-BMT75-68-I	75	50	68	0	112	112	4000	80	60	7.2
C6-DA-BMT85-85-E	85	63	85	0	125	125	3000	80	75	11.3
C6-DA-BMT85-85-I	85	63	85	0	125	125	3000	80	75	11.6

■ E: 外部出水    ■ I: 内部出水  
 External coolant    Internal coolant

DF-BMT

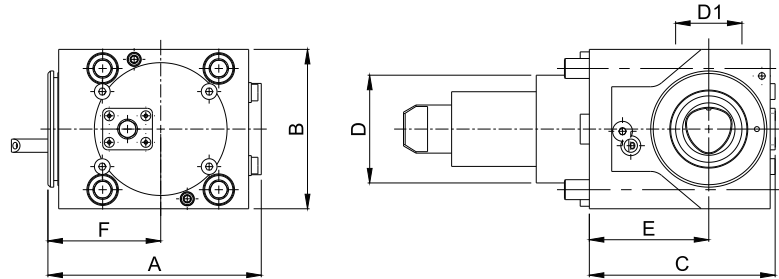

訂貨型號 Order Code	D	D1	C	E	F	A	B	Max R.P.M	CP Bar/PSL	Nm	Kg
C3-DF-BMT55-70-E	55	32	104	70	67	121	85	6000	80	25	7
C3-DF-BMT55-70-I	55	32	104	70	67	126	85	6000	80	25	7.1
C4-DF-BMT65-100-E	65	40	140	100	68	130	96	6000	80	40	10
C4-DF-BMT65-100-I	65	40	140	100	68	134	96	6000	80	40	10.2
C5-DF-BMT75-60-E	75	50	106	60	83	150	112	4000	80	60	12.9
C5-DF-BMT75-60-I	75	50	106	60	83	156	112	4000	80	60	13.5
C6-DF-BMT85-85-E	85	63	141	85	104	184	125	3000	80	75	22.4
C6-DF-BMT85-85-I	85	63	141	85	104	190	125	3000	80	75	23

● E:外部出水 External coolant  
● I:內部出水 Internal coolant

TR/LE-MZ

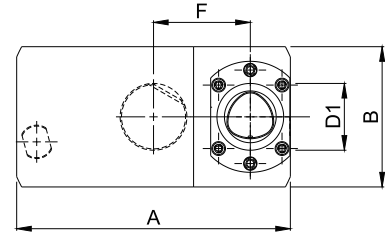
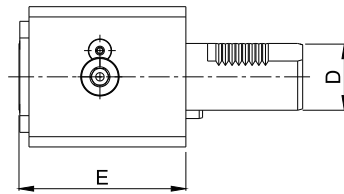

訂貨型號 Order Code	D	D1	E	F	A	B	CP Bar/PSL	Nm	Kg
C4-TR/LE-MZ40V-100	40	40	100	58	164	84	80	50	6.2
C4-TR/LE-MZ40X-100	40	40	100	63	132	84	80	50	5.3
C6-TR/LE-MZ50V-105	50	63	105	42	169	106	80	90	10.2

- R:右手型      ■ L:左手型  
 Right-hand type      Left-hand type

TR/LI-MZ

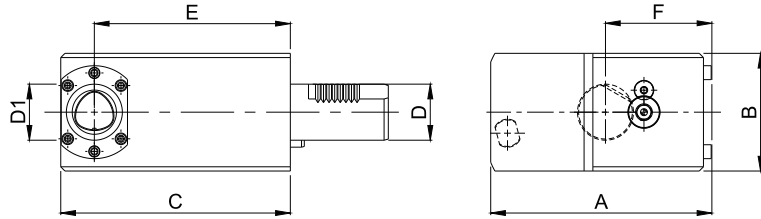

訂貨型號 Order Code	D	D1	C	E	F	A	B	CP Bar/PSL	Nm	Kg
C4-TR/LI-MZ40V-140	40	40	164	140	76	158	84	80	50	10.1
C4-TR/LI-MZ40X-150	40	40	174	150	10	142	84	80	50	9.5
C6-TR/LI-MZ50V-170	50	63	212	170	70	155	106	80	90	17.9

- R:右手型  
Right-hand type
 
■ L:左手型  
Left-hand type



TR/LE-MZ-DT

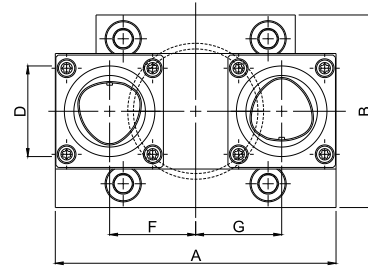
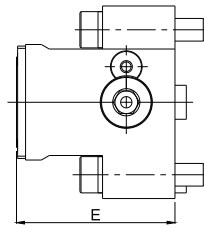

訂貨型號 Order Code	D	E	F	G	A	B	CP Bar/PSL	Nm	Kg
C5-TR/LE-MZ68A-50-60-DT	40	90	50	60	174	84	80	70	10

- R:右手型      ■ L:左手型
- Right-hand type      Left-hand type

TR/LI-MZ-DT

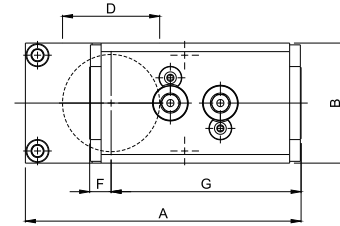
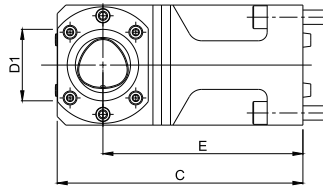

訂貨型號 Order Code	D	D1	C	E	F	G	A	B	CP Bar/PSL	Nm	Kg
C5-TR/LI-MZ68A-15-133-DT	68	50	172	140	15	133	193	84	80	70	9.8

- R:右手型      ■ L:左手型  
 Right-hand type      Left-hand type

DA-MZ

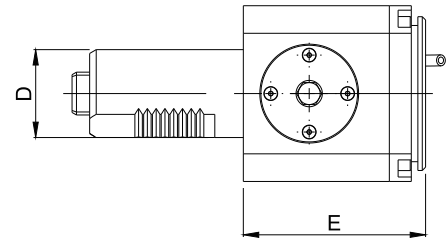
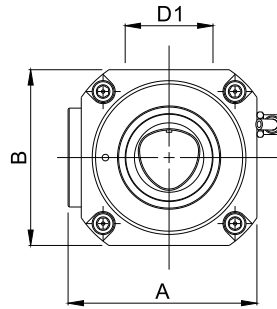

訂貨型號 Order Code	D	D1	E	F	A	B	Max R.P.M	CP Bar/PSL	Nm	Kg
C4-DA-MZ40V-83-E	40	40	83	0	86	80	6000	80	40	3.8
C4-DA-MZ40V-83-I	40	40	83	0	86	80	6000	80	40	3.8
C4-DA-MZ40X-83-E	40	40	83	0	80	80	6000	80	40	3.7
C4-DA-MZ40X-83-I	40	40	83	0	80	80	6000	80	40	3.7

■ E:外部出水 External coolant  
■ I:內部出水 Internal coolant

DF-MZ

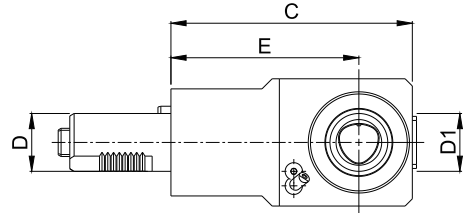
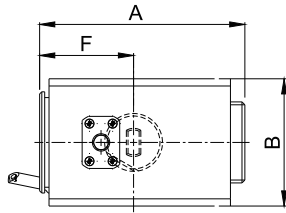

訂貨型號 Order Code	D	D1	C	E	F	A	B	Max R.P.M	CP Bar/PSL	Nm	Kg
C4-DF-MZ40V-130-E	40	40	169	130	62	142	88	6000	80	40	9.9
C4-DF-MZ40V-130-I	40	40	169	130	62	142	88	6000	80	40	10.1
C5-DF-MZ50V-160-E	50	50	209	160	86	165	104	4000	80	60	16.5
C5-DF-MZ50V-160-I	50	50	209	160	86	170	104	4000	80	60	17.1

■ E: 外部出水    ■ I: 內部出水  
 External coolant    Internal coolant

TR/LE-MS

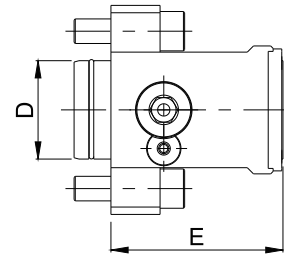
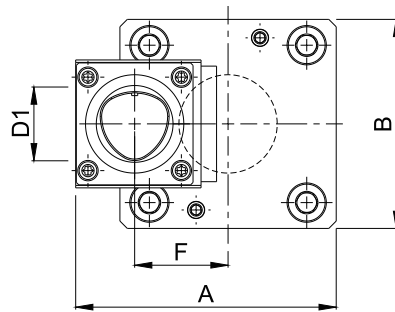
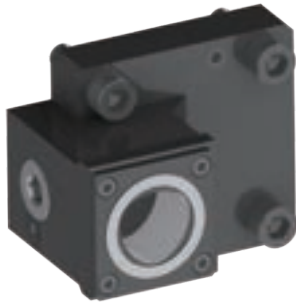

訂貨型號 Order Code	D	D1	E	F	A	B	CP Bar/PSL	Nm	Kg
C4-TR/LE-MS40A-75	40	40	75	43	117	77	80	50	3
C4-TR/LE-MS60A-80	60	40	80	41	130	108	80	50	6.2
C5-TR/LE-MS60A-95	60	50	95	33	130	108	80	70	6.6

- R:右手型  
Right-hand type
 
■ L:左手型  
Left-hand type

TR/LI-MS

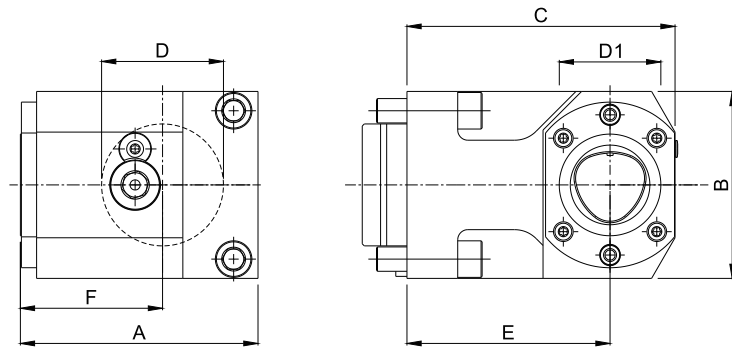

訂貨型號 Order Code	D	D1	C	E	F	A	B	CP Bar/PSL	Nm	Kg
C4-TR/LI-MS40A-100	40	40	124	100	32	100	77	80	50	5.8
C4-TR/LI-MS60A-90	60	40	114	90	65	130	108	80	50	7.8
C5-TR/LI-MS60A-90	60	50	122	90	65	130	108	80	70	8.8
C6-TR/LI-MS60A-110	60	63	152	110	37	130	130	80	90	12.3

■ R:右手型      ■ L:左手型  
 Right-hand type      Left-hand type

TR/LE-MS-DT

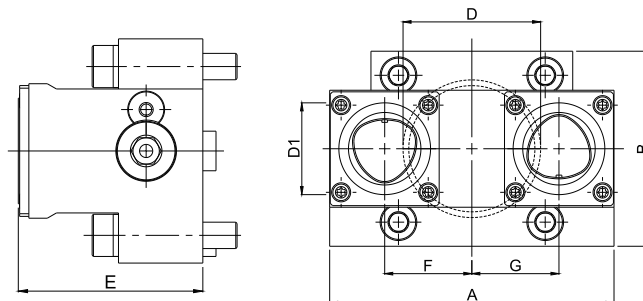

訂貨型號 Order Code	D	D1	E	F	G	A	B	CP Bar/PSL	Nm	Kg
C4-TR/LE-MS40A-43-43-DT	40	40	75	43	43	134	77	80	50	4.3
C4-TR/LE-MS60A-45-70-DT	60	40	80	45	70	134	108	80	50	7.7
C4-TR/LE-MS60A-37-62-DT	60	50	95	37	62	163	108	80	70	8.5

■ R:右手型      ■ L:左手型  
 Right-hand type      Left-hand type

TR/LE-MS-YT

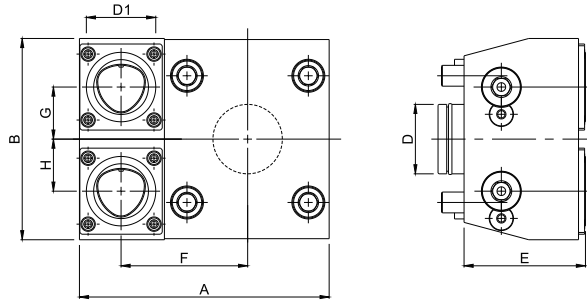

訂貨型號 Order Code	D	D1	E	F	G	H	A	B	CP Bar/PSL	Nm	Kg
C4-TR/LE-MS40A-70-25-YT	40	40	72	70	25	25	144	101	80	50	4.8
C4-TR/LE-MS60A-82-29-YT	60	40	80	82	29	29	171	108	80	50	7.4

- R:右手型 Right-hand type
- L:左手型 Left-hand type



DA-MS

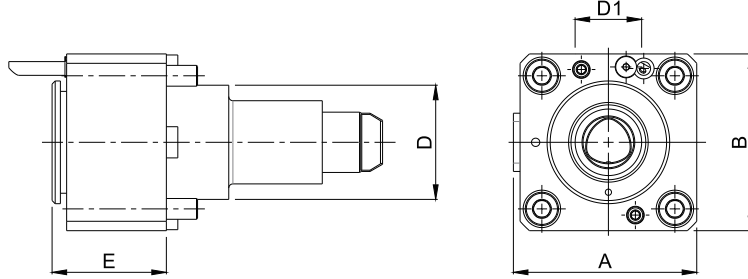

訂貨型號 Order Code	D	D1	E	F	A	B	Max R.P.M	CP Bar/PSL	Nm	Kg
C3-DA-MS40A-64-I	40	32	64	0	96	80	6000	80	25	3.5
C4-DA-MS40A-58-E	40	40	58	0	96	86	6000	80	40	3
C4-DA-MS60A-65-E	60	40	65	0	130	108	6000	80	40	6.5
C4-DA-MS60A-92-I	60	40	92	0	130	108	6000	80	40	9.2
C5-DA-MS60A-69-E	60	50	69	0	130	108	6000	80	60	6.5

■ E:外部出水    ■ I:内部出水  
 External coolant    Internal coolant

DF-MS

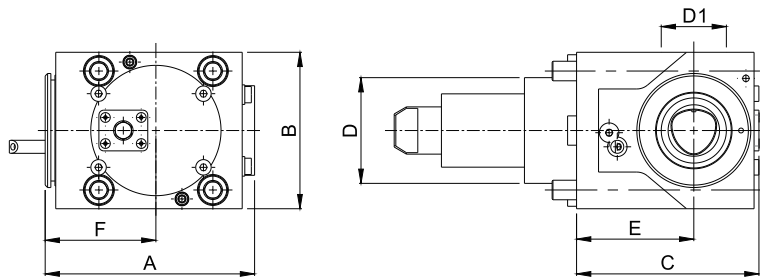

訂貨型號 Order Code	D	D1	C	E	F	A	B	Max R.P.M	CP Bar/PSL	Nm	Kg
C4-DF-MS40A-85-E	40	40	125	85	65	130	80	6000	80	40	6.5
C4-DF-MS40A-85-I	40	40	125	85	65	134	80	6000	80	40	6.7
C4-DF-MS60A-90-E	60	40	136	90	60	130	108	6000	80	40	13
C4-DF-MS60A-90-I	60	40	136	90	60	133	108	6000	80	40	12
C5-DF-MS60A-90-E	60	50	136	90	60	130	108	6000	80	60	12
C5-DF-MS60A-90-I	60	50	136	90	60	133	108	6000	80	60	12

■ E:外部出水    ■ I:内部出水  
 External coolant    Internal coolant

**TR/LI-NA**

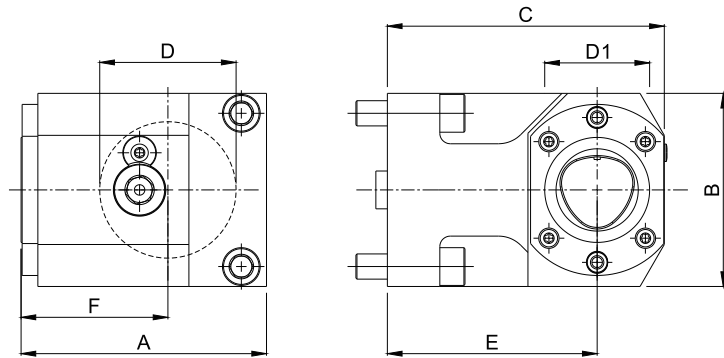

訂貨型號 Order Code	D	C	E	F	A	B	CP Bar/PSL	Nm	Kg
C4-TR/LI-55NA-75	40	99	75	25	96	84	80	50	4.5
C4-TR/LI-65NA-90	40	114	90	10	98	94	80	50	6

- R:右手型      ● L:左手型
- Right-hand type      Left-hand type

VDI刀座  
Tool Holder

TR/LI-NA-S

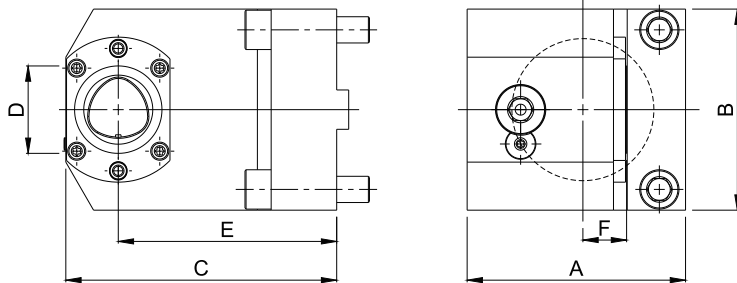
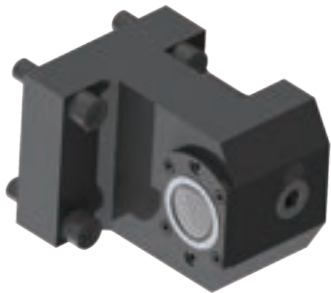

訂貨型號 Order Code	D	C	E	F	A	B	CP Bar/PSL	Nm	Kg
C4-TR/LI-65NA-90-S	40	114	90	45	116	94	80	50	3.9

- R:右手型      ■ L:左手型
- Right-hand type      Left-hand type

**TR/LE-NA-DT**

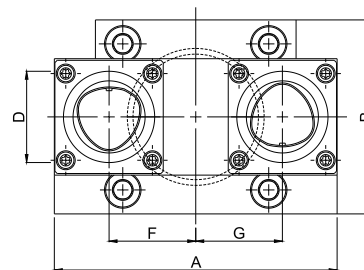
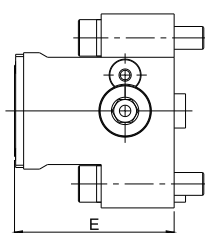

訂貨型號 Order Code	D	E	F	G	A	B	CP Bar/PSL	Nm	Kg
C4-TR/LE-55NA-25-105-DT	40	50	25	105	178	84	80	50	5.2
C4-TR/LE-65NA-25-125-DT	40	50	25	125	198	96	80	50	7.7

- R:右手型      ● L:左手型
- Right-hand type      Left-hand type

DA-NA

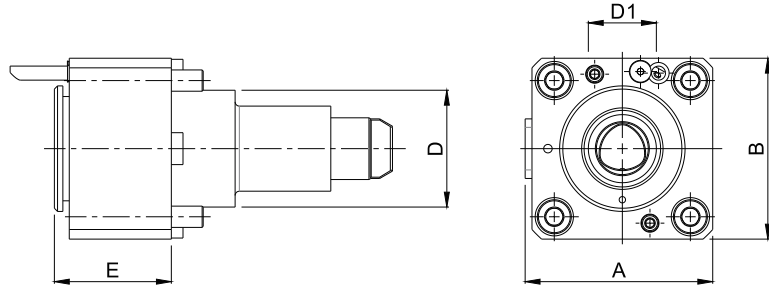

訂貨型號 Order Code	D	D1	E	F	A	B	Max R.P.M	CP Bar/PSL	Nm	Kg
C3-DA-55NA-55-E	55	32	55	0	79	84	6000	80	25	3
C3-DA-55NA-55-I	55	32	55	0	79	84	6000	80	25	3.2
C4-DA-65NA-53-E	65	40	53	0	100	96	6000	80	40	4.6
C4-DA-65NA-53-I	65	40	53	0	100	96	6000	80	40	4.7

■ E:外部出水 External coolant  
■ I:内部出水 Internal coolant

DF-NA

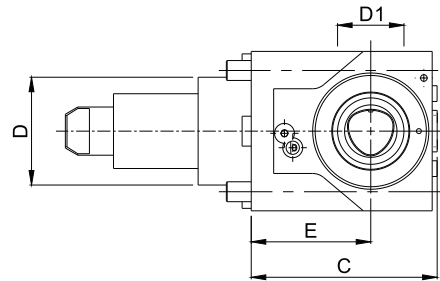
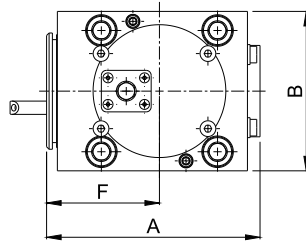

訂貨型號 Order Code	D	D1	C	E	F	A	B	Max R.P.M	CP Bar/PSL	Nm	Kg
C3-DF-55NA-65-E	55	32	100	65	50	99	84	6000	80	25	4.6
C3-DF-55NA-65-I	55	32	100	65	50	104	84	6000	80	25	4.8
C4-DF-65NA-65-E	65	40	105	65	68	130	96	6000	80	40	7.3
C4-DF-65NA-65-I	65	40	105	65	68	134	96	6000	80	40	7.5

■ E:外部出水    ■ I:內部出水  
 External coolant    Internal coolant

TR/LI-OK

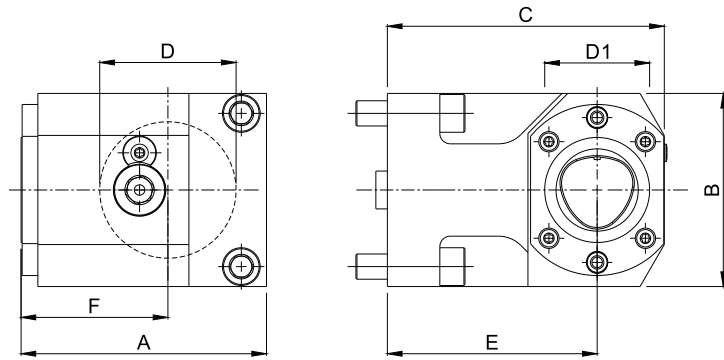

訂貨型號 Order Code	D	C	E	F	A	B	CP Bar/PSL	Nm	Kg
C4-TR/LI-OK60A-90	40	114	90	17	117	95	80	50	5.8

- R:右手型      ● L:左手型
- Right-hand type      Left-hand type



TR/LI-OK-S

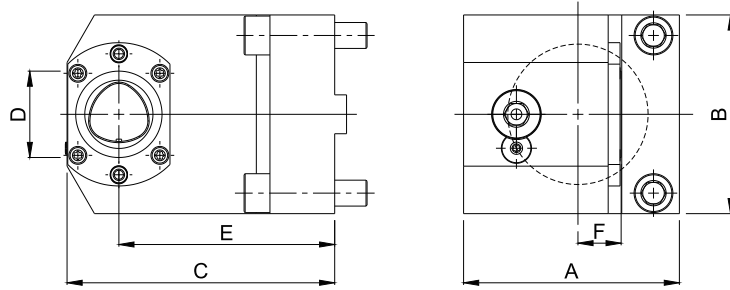

訂貨型號 Order Code	D	C	E	F	A	B	CP Bar/PSL	Nm	Kg
C4-TR/LI-OK60A-90-S	40	114	90	60	110	95	80	50	5.2

- R:右手型      ■ L:左手型
- Right-hand type      Left-hand type

VDI刀座  
Tool Holder

TR/LE-OK-DT

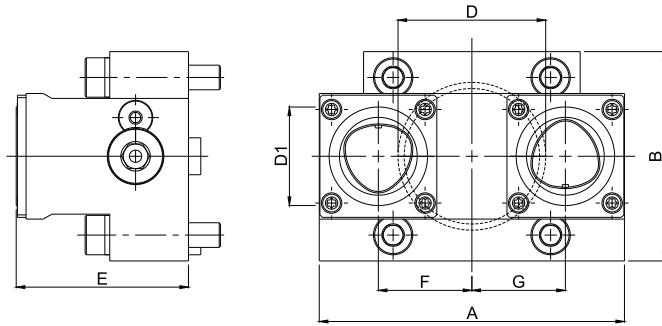

訂貨型號 Order Code	D	D1	E	F	G	A	B	CP Bar/PSL	Nm	Kg
C4-TR/LE-OK55A-67-67-DT	55	40	50	67	67	182	86	80	50	5.9

■ R:右手型      ■ L:左手型  
 Right-hand type      Left-hand type

TR/LE-OK-YT

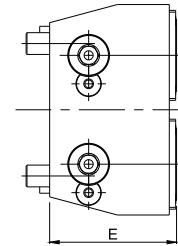
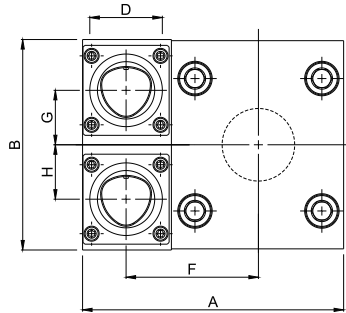

訂貨型號 Order Code	D	E	F	G	H	A	B	CP Bar/PSL	Nm	Kg
C4-TR/LE-OK60A-25-26-YT	40	65	25	26	26	149	103	80	50	4.8
C5-TR/LE-OK60B-28-32-YT	50	73	28	32	32	170	128	80	70	6.9

- R:右手型      ■ L:左手型
- Right-hand type      Left-hand type

VDI刀座  
Tool Holder

TR/LI-OK-DT

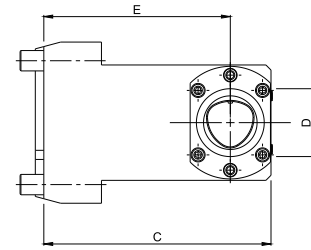
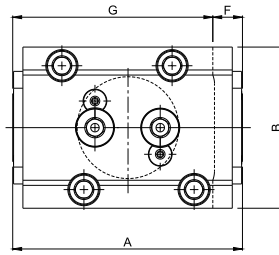

訂貨型號 Order Code	D	C	E	F	G	A	B	CP Bar/PSL	Nm	Kg
C4-TR/LI-OK60C-110-DT	40	134	110	17	118	135	95	80	50	9

- R:右手型 Right-hand type   
 ■ L:左手型 Left-hand type

DA-OK

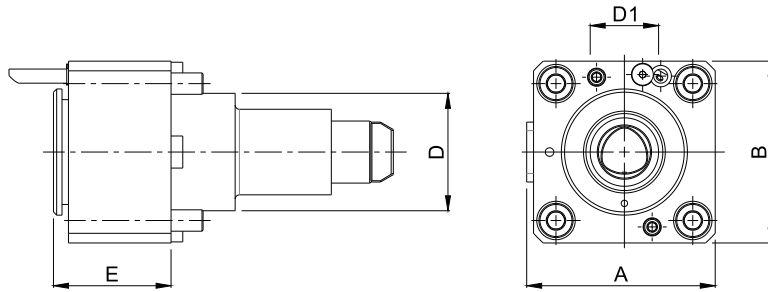

訂貨型號 Order Code	D	D1	E	F	A	B	Max R.P.M	CP Bar/PSL	Nm	Kg
C4-DA-OK60A-54-E	60	40	54	0	120	97	6000	80	40	4.6
C4-DA-OK60A-60-I	60	40	60	0	120	97	6000	80	40	4.9

- E: 外部出水  
External coolant
 ■ I: 内部出水  
Internal coolant

DF-OK

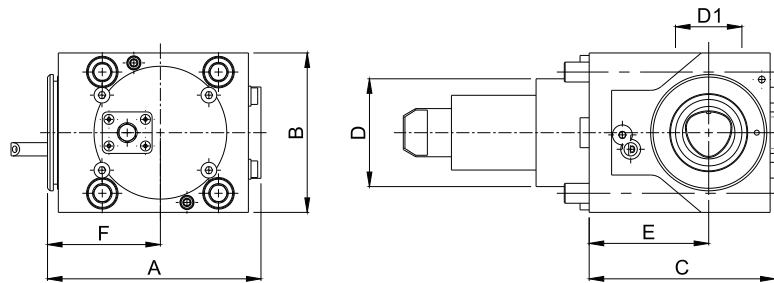

訂貨型號 Order Code	D	D1	C	E	F	A	B	Max R.P.M	CP Bar/PSL	Nm	Kg
C4-DF-OK60A-70-E	60	40	111	70	85	143	98	6000	80	40	9.3
C4-DF-OK60A-70-I	60	40	111	70	85	143	98	6000	80	40	9.4

■ E:外部出水 External coolant  
■ I:内部出水 Internal coolant

**R/LE-69880**

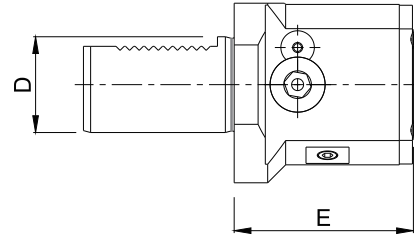
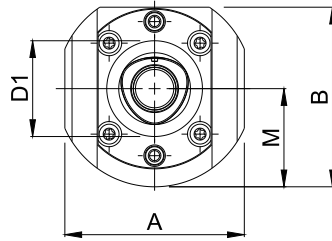

訂貨型號 Order Code	D	D1	E	M	A	B	CP Bar/PSL	Nm	Kg
C3-R/LE30-00060	30	32	60	34	50	61	80	35	1
C4-R/LE40-00075	40	40	75	41	75	75	80	50	2.2
C5-R/LE40-00085	40	50	85	41	75	82	80	70	3.2
C4-R/LE50-00065	50	40	65	49	70	83	80	50	2.2
C5-R/LE50-00085	50	50	85	49	83	90	80	70	3.2
C5-R/LE60-00075	60	50	75	58	80	100	80	70	5.7
C6-R/LE60-00095	60	63	95	58	84	111	80	90	6.1

- R:右手型      ■ L:左手型
- Right-hand type      Left-hand type

**R/LBC-69880**

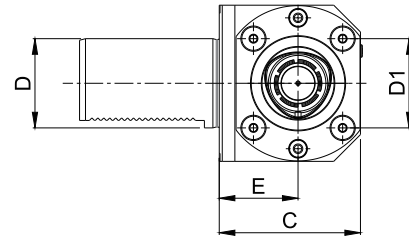
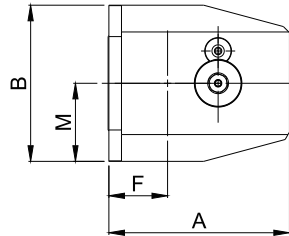

訂貨型號 Order Code	D	D1	C	E	F	M	A	B	CP Bar/PSL	Nm	Kg
C3-R/LBC30-41020	30	32	60	41	20	30	74	57	80	35	2.1
C3-R/LBC30-41030	30	32	60	41	30	30	74	57	80	35	2.2
C4-R/LBC40-51030	40	40	75	51	30	38	86	75	80	50	3.2
C4-R/LBC40-51040	40	40	75	51	40	38	86	75	80	50	3.2
C5-R/LBC40-53030	40	50	85	53	30	41	99	82	80	70	5.7
C5-R/LBC40-53040	40	50	85	53	40	41	99	82	80	70	5.7
C5-R/LBC50-53030	50	50	85	53	30	43	99	86	80	70	5.7
C5-R/LBC50-53040	50	50	85	53	40	43	99	86	80	70	5.7
C5-R/LBC60-43040	60	50	75	43	40	53	99	94	80	70	5.7
C6-R/LBC60-53040	60	63	95	53	40	53	122	105	80	90	6

■ R:右手型      ■ L:左手型  
 Right-hand type      Left-hand type