

















Material related application chart / 材料应用表

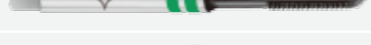
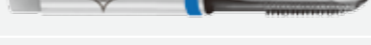













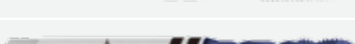

No. G 序号	Material group	材料类别	M&T-JIS M	MF&T-JIS MF
G01	Structural steels <1000 N / mm ²	结构钢<1000N/mm ²	○	○
G02	Structural steels >900 N / mm ²	结构钢>900N/mm ²	○	○
G03	Case hardening steels <1000 N / mm ²	表面硬化钢<1000N/mm ²	○	○
G04	Case hardening steels >900 N / mm ²	表面硬化钢>900N/mm ²	○	○
G05	Heat treatable steels <1000 N / mm ²	热处理钢<1000N/mm ²	○	○
G06	Heat treatable steels >900 N / mm ²	热处理钢>900N/mm ²	○	○
G07	Nitriding steels	氮化钢	○	○
G08	Carbon tool steels	碳素工具钢	○	○
G09	Heat resisting steels	耐热钢	○	○
G10	Cr stainless steels, sulphured	Cr不锈钢	○	○
G11	Cr stainless steels, ferritic and martensitic	Cr不锈钢、铁素体不锈钢、马氏体不锈钢	○	○
G12	Cr-Ni stainless steels, austenitic	Cr-Ni不锈钢、奥氏体不锈钢	○	○
G13	Free-cutting steels	易切削钢	○	○
G14	Cast steels <1000 N / mm ²	铸钢<1000N/mm ²	○	○
G15	Cast steels >900 N / mm ²	铸钢>900N/mm ²	○	○
G16	Malleable cast iron	可锻铸铁	○	○
G17	Nodular graphite cast iron	结节性石墨铸铁(球墨铸铁)	○	○
G18	Lamellar graphite cast iron (grey cast iron)	片状石墨铸铁(灰铸铁)	○	○
G19	Vermicular graphite cast iron	蠕墨铸铁	○	○
G20	Copper	铜	○	○
G21	Hard brass (Ms 58, short chipping)	硬黄铜(Ms58,短切屑)	○	○
G22	Soft brass (MS 63, long chipping)	软黄铜(Ms63,长切屑)	○	○
G23	Red brass	红铜	○	○
G24	Phosphor bronze	磷青铜	○	○
G25	Wrought alloy of aluminium	锻造铝合金	○	○
G26	Aluminium cast alloy Si 0.5 %-5 %	铸造铝合金(Si 0.5% ~ 5%)	○	○
G27	Aluminium cast alloy Si 5 %-10 %	铸造铝合金(Si 5% ~ 10%)	○	○
G28	Aluminium cast alloy Si >10 %	铸造铝合金(Si>10%)	○	○
G29	Wrought alloy of magnesium	锻造镁合金	○	○
G30	Cast alloy of magnesium	铸造镁合金	○	○
G31	Alloy of nickel	镍合金	○	○
G32	Titanium and alloy of titanium	钛、钛合金	○	○
G33	Ferro-TiC	Ferro-TiC钢结硬质合金	○	○
G34	Thermoplastic compounds / synthetics	热塑性复合材料 / 合成纤维	○	○
G35	High strength structural steels fine grained	高强度细晶粒结构钢	○	○

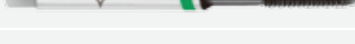
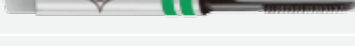
Table of contents / 目录

钻头	钻头	钻头	钻头	M DIN 371/376	Page 页码
●	●				105/4 M1
		●	●		131/3 M1
●	●				105/4 DUO M2
		●	●		131/3 DUO M2
●	●				105/4 M3
		●	●		131/3 M3
●	●				105/4 DUO M4
		●	●		131/3 DUO M4
●	●	●	●		105/3 M5
●	●	●	●		105/3 DUO M6
●	●				105/4 M7
		●	●		131/3 M7
●	●				105/4 DUO M8
		●	●		131/3 DUO M8
●	●				105/4 M9
		●	●		131/3 M9
●	●				105/4 DUO M10
		●	●		131/3 DUO M10

T-JIS M

Page
页码

•	•			105/4	M11
		•		131/3	M11
•	•			105/4 DUO	M12
		•		131/3 DUO	M12
•	•			105/4	M13
		•		131/3	M13
•	•			105/4 DUO	M14
		•		131/3 DUO	M14
•	•	•		105/3	M15
•	•	•		105/3 DUO	M16
•	•			105/4	M17
		•		131/3	M17
•	•			105/4 DUO	M18
		•		131/3 DUO	M18
•	•			105/4	M19
		•		131/3	M19
•	•			105/4 DUO	M20
		•		131/3 DUO	M20

DIN MF 371/374

Page
页码

•	•			105/4	MF1
		•		131/3	MF1
•	•			105/4	MF2
		•		131/3	MF2
•	•	•		105/3	MF3
•	•			105/4	MF4
		•		131/3	MF4
•	•			105/4	MF5
		•		131/3	MF5

T-JIS MF

•	•			105/4	MF6
		•		131/3	MF6
•	•			105/4	MF7
		•		131/3	MF7
•	•			105/4	MF8
		•		131/3	MF8
•	•	•		105/3	MF9
•	•			105/4	MF10
		•		131/3	MF10

M DIN 371/376

HSSE

HSSE-PM DUO

ISO 2 (6H)

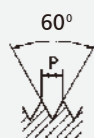
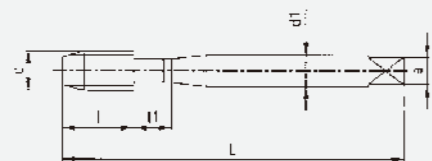

• For stock /有库存

Norm /标准

Class of tolerance /公差



L	105/4		131/3		DIN 371		DIN 376		d	P	Art.	Art.	Art.	Art.
	l	l1	l	l1	d1	a	d1	a						
45	8		8		2,8	2,1			M 2	0,4	1,6	C822462 ○		C878484 ○
50	9		9		2,8	2,1			M 2,5	0,45	2,05	C822497 ○		C878506 ○
56	11	7	6	11	3,5	2,7	2,2	1,8	M 3	0,5	2,5	C822519 ●	C861077 ○	C878514 ●
63	13	8	7,5	13	4,5	3,4	2,8	2,1	M 4	0,7	3,3	C822535 ●	C861093 ○	C878530 ●
70	16	9	9	16	6	4,9	3,5	2,7	M 5	0,8	4,2	C822543 ●	C861107 ○	C878549 ●
80	19	11	11	18	6	4,9	4,5	3,4	M 6	1	5	C822551 ●	C861115 ○	C878557 ●
90	22	13	13	21	8	6,2	6	4,9	M 8	1,25	6,8	C822578 ●	C861123 ○	C878565 ●
100	24	15	16	22	10	8	7	5,5	M 10	1,5	8,5	C822586 ●	C861131 ○	C878573 ●
110	29		18				9	7	M 12	1,75	10,2		C822594 ●	C878581 ●
110	30		20				11	9	M 14	2	12		C822608 ○	C878603 ○
110	32		20				12	9	M 16	2	14		C822616 ○	C878611 ○
125	34		22				14	11	M 18	2,5	15,5		C822624 ○	C878638 ○
140	34		25				16	12	M 20	2,5	17,5		C822632 ○	C878646 ○

● 标准库存品 ● Standard stock item

○ 非标准库存品, 直径 < 12mm, 最小起订量是200支; 直径 ≥ 12mm, 最小起订量是100支

○ Non-standard stock item, Diameter < 12 mm minimum order quantity is 200 pcs ; Diameter ≥ 12 minimum order quantity is 100 pcs

**105/4 YELLOW RING
131/3 YELLOW RING**

G20 Copper, G21 hard brass (Ms 58, short chipping), G22 soft brass (Ms 63, long chipping), G23 red brass, G24 phosphor bronze, G25 wrought alloy of aluminium, G29 wrought alloy of magnesium, G34 thermoplastic compounds/synthetics

**105/4 YELLOW RING
131/3 YELLOW RING**

G20 铜, G21 硬黄铜 (Ms 58, 短切削), G22 软黄铜 (Ms 63, 长切削), G23 红铜, G24 磷青铜, G25 锻造铝合金, G29 锻造镁合金, G34 热塑性复合材料/合成纤维

M DIN 371/376

HSSE

HSSE-PM DUO

ISO 2 (6H)

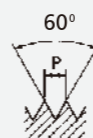
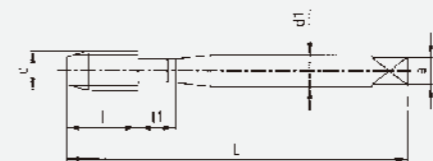

• For stock /有库存

Norm /标准

Class of tolerance /公差



L	105/4		131/3		DIN 371		DIN 376		d	P	Art.	Art.	Art.	Art.
	l	l1	l	l1	d1	a	d1	a						
56	11	7	6	11	3,5	2,7	2,2	1,8	M 3	0,5	2,5	C843403 ●		C843422 ●
63	13	8	7,5	13	4,5	3,4	2,8	2,1	M 4	0,7	3,3	C843404 ●		C843423 ●
70	16	9	9	16	6	4,9	3,5	2,7	M 5	0,8	4,2	C843405 ●		C843424 ●
80	19	11	11	18	6	4,9	4,5	3,4	M 6	1	5	C843406 ●		C843425 ●
90	22	13	13	21	8	6,2	6	4,9	M 8	1,25	6,8	C843407 ●		C843426 ●
100	24	15	16	22	10	8	7	5,5	M 10	1,5	8,5	C843408 ●		C843428 ●
110	29		18				9	7	M 12	1,75	10,2		C843409 ●	C843429 ●
110	30		20				11	9	M 14	2	12		C843410 ○	C843430 ○
110	32		20				12	9	M 16	2	14		C843411 ○	C843431 ○
125	34		22				14	11	M 18	2,5	15,5		C843412 ○	C843432 ○
140	34		25				16	12	M 20	2,5	17,5		C843413 ○	C843433 ○

● 标准库存品 ● Standard stock item

○ 非标准库存品, 直径 < 12mm, 最小起订量是200支; 直径 ≥ 12mm, 最小起订量是100支

○ Non-standard stock item, Diameter < 12 mm minimum order quantity is 200 pcs ; Diameter ≥ 12 minimum order quantity is 100 pcs

**105/4 DUO YELLOW RING
131/3 DUO YELLOW RING**

G20 Copper, G21 hard brass (Ms 58, short chipping), G22 soft brass (Ms 63, long chipping), G23 red brass, G24 phosphor bronze, G25 wrought alloy of aluminium, G29 wrought alloy of magnesium, G34 thermoplastic compounds/synthetics

**105/4 YELLOW RING DUO
131/3 YELLOW RING DUO**

G20 铜, G21 硬黄铜 (Ms 58, 短切削), G22 软黄铜 (Ms 63, 长切削), G23 红铜, G24 磷青铜, G25 锻造铝合金, G29 锻造镁合金, G34 热塑性复合材料/合成纤维

M DIN 371/376

HSSE

HSSE-PM DUO

ISO 2 (6H)

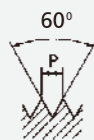
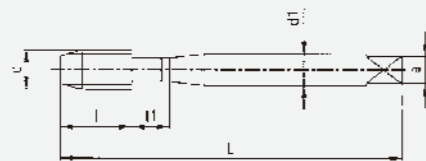

• For stock /有库存

Norm /标准	DIN 371	DIN 376	DIN 371	DIN 376
Class of tolerance /公差	ISO 2 (6H)	ISO 2 (6H)	ISO 2 (6H)	ISO 2 (6H)
	B/4	B/4	C/2,5	C/2,5-3

L	105		131/3		DIN 371		DIN 376		d	P	Art.	Art.	Art.	Art.
	l	l ₁	l	l ₁	d ₁	a	d ₁	a						
45	8		8		2,8	2,1			M 2	0,4	1,6	C852000 ○		C873040 ○
50	9		9		2,8	2,1			M 2,5	0,45	2,05	C852035 ○		C871560 ○
56	11	7	6	11	3,5	2,7	2,2	1,8	M 3	0,5	2,5	C856707 ●	C852051 ○	C844245 ●
63	13	8	7,5	13	4,5	3,4	2,8	2,1	M 4	0,7	3,3	C837176 ●	C852078 ○	C845500 ● C812299 ○
70	16	9	9	16	6	4,9	3,5	2,7	M 5	0,8	4,2	C837184 ●	C852086 ○	C845659 ● C871609 ○
80	19	11	11	18	6	4,9	4,5	3,4	M 6	1	5	C837192 ●	C852094 ○	C851829 ● C871617 ○
90	22	13	13	21	8	6,2	6	4,9	M 8	1,25	6,8	C837206 ●	C852108 ○	C865285 ● C871625 ○
100	24	15	16	22	10	8	7	5,5	M 10	1,5	8,5	C837214 ●	C852116 ○	C865293 ● C871633 ○
110	29		18				9	7	M 12	1,75	10,2		C837222 ●	C857150 ●
110	30		20				11	9	M 14	2	12		C837230 ○	C857177 ○
110	32		20				12	9	M 16	2	14		C837249 ○	C857193 ○
125	34		22				14	11	M 18	2,5	15,5		C852124 ○	C857274 ○
140	34		25				16	12	M 20	2,5	17,5		C852132 ○	C857304 ○

● 标准库存品 ● Standard stock item
 ○ 非标准库存品,直径 < 12mm, 最小起订量是200支; 直径 ≥ 12mm, 最小起订量是100支
 ○ Non-standard stock item, Diameter < 12 mm minimum order quantity is 200 pcs ; Diameter ≥ 12 minimum order quantity is 100 pcs

105/4,131/3 BLACK RING

G01 structural steels < 1000 N/mm², G03 case hardening steels < 1000 N/mm², G08 carbon tool steels, G10 Cr stainless, sulphured, G13 free-cutting steels, G14 cast steels < 1000 N/mm²

105/4,131/3 BLACK RING

G01 结构钢 < 1000 N/mm², G03 表面硬化钢 < 1000 N/mm², G08 碳素工具钢, G10 Cr 不锈钢, G13 易切钢, G14 铸钢 < 1000 N/mm²

105/4 DUO 105/4 DUO 131/3 DUO 131/3 DUO



DIN 371	DIN 376	DIN 371	DIN 376
ISO 2 (6H)	ISO 2 (6H)	ISO 2 (6H)	ISO 2 (6H)
B/4	B/4	C/2,5	C/2,5

Art.	Art.	Art.	Art.
C843217 ●		C843239 ●	
C843218 ●		C843240 ●	
C843219 ●		C843241 ●	
C843220 ●		C843242 ●	
C843221 ●		C843243 ●	
C843231 ●		C843244 ●	
	C843232 ●		C843245 ●
	C843233 ○		C843246 ○
	C843234 ○		C843247 ○

● 标准库存品 ● Standard stock item
 ○ 非标准库存品,直径 < 12mm, 最小起订量是200支; 直径 ≥ 12mm, 最小起订量是100支
 ○ Non-standard stock item, Diameter < 12 mm minimum order quantity is 200 pcs ; Diameter ≥ 12 minimum order quantity is 100 pcs

105/4,131/3 DUO BLACK RING

G01 structural steels < 1000 N/mm², G03 case hardening steels < 1000 N/mm², G08 carbon tool steels, G10 Cr stainless, sulphured, G13 free-cutting steels, G14 cast steels < 1000 N/mm²

105/4,131/3 DUO BLACK RING

G01 结构钢 < 1000 N/mm², G03 表面硬化钢 < 1000 N/mm², G08 碳素工具钢, G10 Cr 不锈钢, G13 易切钢, G14 铸钢 < 1000 N/mm²

M DIN 371/376

HSSE

HSSE-PM DUO

ISO 2 (6H)

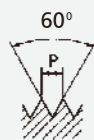
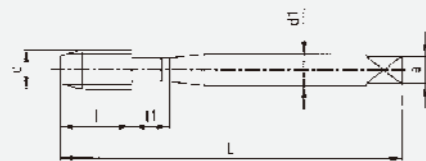

• For stock /有库存

Norm /标准
Class of tolerance /公差



L	105/3		DIN 371		DIN 376		d	P	Art.	Art.	
	l	l ₁	d ₁	a	d ₁	a					
45	8		2,8	2,1			M 2	0,4	1,6	C871374 ○	
50	9		2,8	2,1			M 2,5	0,45	2,05	C871382 ○	
56	11	7	3,5	2,7			M 3	0,5	2,5	C837257 ●	
63	13	8	4,5	3,4			M 4	0,7	3,3	C837273 ●	
70	16	9	6	4,9			M 5	0,8	4,2	C837281 ●	
80	19	11	6	4,9			M 6	1	5	C856715 ●	
90	22	13	8	6,2	6	4,9	M 8	1,25	6,8	C837303 ●	C871412 ○
100	24	15	10	8	7	5,5	M 10	1,5	8,5	C837311 ●	C874985 ○
110	29				9	7	M 12	1,75	10,2		C856723 ●
110	32				12	9	M 16	2	14		C852159 ○
140	34				16	12	M 20	2,5	17,5		C852175 ○

● 标准库存品 ● Standard stock item
○ 非标准库存品, 直径 < 12mm, 最小起订量是200支; 直径 ≥ 12mm, 最小起订量是100支
○ Non-standard stock item, Diameter < 12 mm minimum order quantity is 200 pcs ; Diameter ≥ 12 minimum order quantity is 100 pcs

105/3 GREEN RING

G16 malleable cast iron, G17 nodular graphite cast iron, G18 lamellar graphite cast iron (grey cast iron), G19 vermicular graphite cast iron, G26 aluminium cast alloy Si 0.5% – 5%, G27 aluminium cast alloy Si 5% – 10%, G28 aluminium cast alloy Si > 10%, G30 cast alloy of magnesium, G33 ferro-Tic

105/3 GREEN RING

G16 可锻铸铁, G17 结节性石墨铸铁 (球磨铸铁), G18 片状石墨铸铁 (灰铸铁), G19 蠕墨铸铁, G26 铸造铝合金 Si 0.5% – 5%, G27 铸造铝合金 Si 5% – 10%, G28 铸造铝合金 Si > 10%, G30 铸造镁合金, G33 ferro-Tic钢结硬质合金

M DIN 371/376

HSSE

HSSE-PM DUO

ISO 2 (6H)

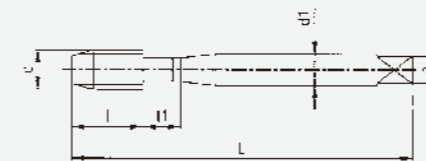

• For stock /有库存

Norm /标准
Class of tolerance /公差



L	105/3		DIN 371		DIN 376		d	P	Art.	Art.	
	l	l ₁	d ₁	a	d ₁	a					
56	11	7	3,5	2,7			M 3	0,5	2,5	C843446 ●	
63	13	8	4,5	3,4			M 4	0,7	3,3	C843447 ●	
70	16	9	6	4,9			M 5	0,8	4,2	C843448 ●	
80	19	11	6	4,9			M 6	1	5	C843449 ●	
90	22	13	8	6,2	6	4,9	M 8	1,25	6,8	C843452 ●	
100	24	15	10	8	7	5,5	M 10	1,5	8,5	C843453 ●	
110	29				9	7	M 12	1,75	10,2		C843454 ●
110	32				12	9	M 16	2	14		C843456 ○
140	34				16	12	M 20	2,5	17,5		C843458 ○

● 标准库存品 ● Standard stock item
○ 非标准库存品, 直径 < 12mm, 最小起订量是200支; 直径 ≥ 12mm, 最小起订量是100支
○ Non-standard stock item, Diameter < 12 mm minimum order quantity is 200 pcs ; Diameter ≥ 12 minimum order quantity is 100 pcs

105/3 DUO GREEN RING

G16 malleable cast iron, G17 nodular graphite cast iron, G18 lamellar graphite cast iron (grey cast iron), G19 vermicular graphite cast iron, G26 aluminium cast alloy Si 0.5% – 5%, G27 aluminium cast alloy Si 5% – 10%, G28 aluminium cast alloy Si > 10%, G30 cast alloy of magnesium, G33 ferro-Tic

105/3 DUO GREEN RING

G16 可锻铸铁, G17 结节性石墨铸铁 (球磨铸铁), G18 片状石墨铸铁 (灰铸铁), G19 蠕墨铸铁, G26 铸造铝合金 Si 0.5% – 5%, G27 铸造铝合金 Si 5% – 10%, G28 铸造铝合金 Si > 10%, G30 铸造镁合金, G33 ferro-Tic钢结硬质合金



DIN 371/376

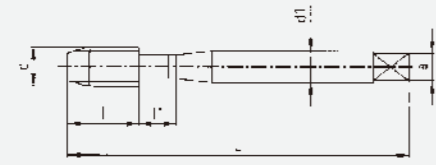

DUO

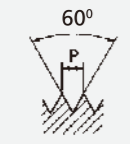
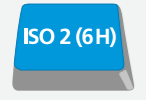

• For stock /有库存

Norm /标准	DIN 371	DIN 376	DIN 371	DIN 376
Class of tolerance /公差	ISO 2 (6H)	ISO 2 (6H)	ISO 2 (6H)	ISO 2 (6H)
	B/4	B/4	C/2,5	C/2,5



L	105/4		131/3		d1	a	d	p	Art.	Art.	Art.	Art.		
	l	l1	l	l1										
45	8		8		2,8	2,1	M 2	0,4	1,6	C893564	○	C825690	○	
50	9		9		2,8	2,1	M 2,5	0,45	2,05	C893556	○	C825828	○	
56	11	7	6	11	3,5	2,7	M 3	0,5	2,5	C893572	●	C825925	●	
63	13	8	7,5	13	4,5	3,4	M 4	0,7	3,3	C893580	●	C826034	●	
70	16	9	9	16	6	4,9	M 5	0,8	4,2	C893599	●	C826085	●	
80	19	11	11	18	6	4,9	M 6	1	5	C893602	●	C826123	●	
90	22	13	13	21	8	6,2	M 8	1,25	6,8	C893610	●	C826212	●	
100	24	15	16	22	10	8	M 10	1,5	8,5	C893629	●	C826247	●	
110	29		18		9	7	M 12	1,75	10,2		C893637	●	C826298	●
110	30		20		11	9	M 14	2	12		C893645	○	C854852	○
110	32		20		12	9	M 16	2	14		C893653	○	C854860	○
125	34		22		14	11	M 18	2,5	15,5		C893661	○	C854879	○
140	34		25		16	12	M 20	2,5	17,5		C893688	○	C854887	○

● 标准库存品 ● Standard stock item
 ○ 非标准库存品, 直径 < 12mm, 最小起订量是200支; 直径 ≥ 12mm, 最小起订量是100支
 ○ Non-standard stock item, Diameter < 12 mm minimum order quantity is 200 pcs ; Diameter ≥ 12 minimum order quantity is 100 pcs

105/4,131/3 BLUE RING

G07 nitriding steels, G09 heat resisting steels, G11 Cr stainless steels, ferritic and martensitic, G12 Cr-Ni stainless steels, austenitic, G31 alloy of nickel, G32 titanium and alloy of titanium

105/4,131/3 BLUE RING

G07 氮化钢, G09 耐热钢, G11 Cr 不锈钢, 铁素体不锈钢和奥氏体不锈钢, G12 Cr-Ni 不锈钢, 奥氏体不锈钢, G31 镍合金, G32 钛和钛合金

105/4
DUO



DIN 371
ISO 2 (6H)
B/4

Art.

- C843285 ●
- C843286 ●
- C843287 ●
- C843289 ●
- C843290 ●
- C843291 ●

105/4
DUO



DIN 376
ISO 2 (6H)
B/4

Art.

- C843292 ●
- C843293 ○
- C843294 ○
- C843295 ○
- C843296 ○

131/3
DUO



DIN 371
ISO 2 (6H)
C/2,5

Art.

- C843299 ●
- C843300 ●
- C843301 ●
- C843302 ●
- C843304 ●
- C843305 ●

131/3
DUO



DIN 376
ISO 2 (6H)
C/2,5

Art.

- C843306 ●
- C843307 ○
- C843308 ○
- C843309 ○
- C843310 ○

● 标准库存品 ● Standard stock item
 ○ 非标准库存品, 直径 < 12mm, 最小起订量是200支; 直径 ≥ 12mm, 最小起订量是100支
 ○ Non-standard stock item, Diameter < 12 mm minimum order quantity is 200 pcs ; Diameter ≥ 12 minimum order quantity is 100 pcs

105/4, 131/3 DUO BLUE RING

G07 nitriding steels, G09 heat resisting steels, G11 Cr stainless steels, ferritic and martensitic, G12 Cr-Ni stainless steels, austenitic, G31 alloy of nickel, G32 titanium and alloy of titanium

105/4, 131/3 DUO BLUE RING

G07 氮化钢, G09 耐热钢, G11 Cr 不锈钢, 铁素体不锈钢和奥氏体不锈钢, G12 Cr-Ni 不锈钢, 奥氏体不锈钢, G31 镍合金, G32 钛和钛合金

M DIN 371/376

- HSSE
- HSSE-PM DUO
- ISO 2 (6H)

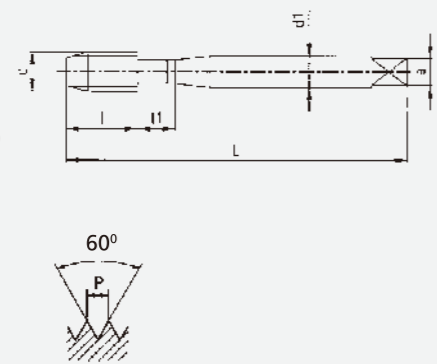

• For stock /有库存

Norm /标准	DIN 371	DIN 376	DIN 371	DIN 376
Class of tolerance /公差	ISO 2 (6H)	ISO 2 (6H)	ISO 2 (6H)	ISO 2 (6H)
	B/4	B/4	C/2,5	C/2,5

L	105/4		131/3		d1	a	d	P	Image	Art.		Art.	
	l	l1	l	l1						Art.	Art.	Art.	Art.
45	8		8		2,8	2,1	M 2	0,4	1,6	C875000 ○		C876007 ○	
50	9		9		2,8	2,1	M 2,5	0,45	2,05	C875027 ○		C876023 ○	
56	11	7	6	11	3,5	2,7	M 3	0,5	2,5	C875035 ●		C876031 ●	
63	13	8	7,5	13	4,5	3,4	M 4	0,7	3,3	C875043 ●		C876058 ●	
70	16	9	9	16	6	4,9	M 5	0,8	4,2	C875051 ●		C876066 ●	
80	19	11	11	18	6	4,9	M 6	1	5	C875078 ●		C876074 ●	
90	22	13	13	21	8	6,2	M 8	1,25	6,8	C875086 ●		C876082 ●	
100	24	15	16	22	10	8	M 10	1,5	8,5	C875094 ●		C876090 ●	
110	29		18		9	7	M 12	1,75	10,2		C875108 ●		C76104 ●
110	30		20		11	9	M 14	2	12		C875116 ○		C76112 ○
110	32		20		12	9	M 16	2	14		C875124 ○		C76120 ○
125	34		22		14	11	M 18	2,5	15,5		C875132 ○		C76139 ○
140	34		25		16	12	M 20	2,5	17,5		C875140 ○		C76147 ○

● 标准库存品 ● Standard stock item
 ○ 非标准库存品, 直径 < 12mm, 最小起订量是200支; 直径 ≥ 12mm, 最小起订量是100支
 ○ Non-standard stock item, Diameter < 12 mm minimum order quantity is 200 pcs ; Diameter ≥ 12 minimum order quantity is 100 pcs

105/4 RED RING
131/3 RED RING
 G02 structural steels >900N/mm², G04 case hardening steels >900N/mm², G05 heat treatable steels <1000N/mm², G06 heat treatable steels >900N/mm², G15 cast steels >900N/mm², G35 High strength structural steels fine grained

105/4 RED RING
131/3 RED RING
 G02 结构钢 >900N/mm², G04 表面硬化钢 >900N/mm², G05 热处理钢 <1000N/mm², G06 热处理钢 >900N/mm², G15 铸钢 >900N/mm², G35 高强度细晶粒结构钢

105/4 DUO 105/4 DUO 131/3 DUO 131/3 DUO



DIN 371	DIN 376	DIN 371	DIN 376
ISO 2 (6H)	ISO 2 (6H)	ISO 2 (6H)	ISO 2 (6H)
B/4	B/4	C/2,5	C/2,5

Art.		Art.		Art.		Art.	
C843314 ●				C843327 ●			
C843315 ●				C843328 ●			
C843316 ●				C843329 ●			
C843317 ●				C843330 ●			
C843318 ●				C843331 ●			
C843319 ●				C843332 ●			
	C843320 ●					C843333 ●	
	C843321 ○					C843334 ○	
	C843322 ○					C843335 ○	
	C843323 ○					C843336 ○	
	C843324 ○					C843337 ○	

● 标准库存品 ● Standard stock item
 ○ 非标准库存品, 直径 < 12mm, 最小起订量是200支; 直径 ≥ 12mm, 最小起订量是100支
 ○ Non-standard stock item, Diameter < 12 mm minimum order quantity is 200 pcs ; Diameter ≥ 12 minimum order quantity is 100 pcs

105/4 DUO RED RING
131/3 DUO RED RING
 G02 structural steels >900N/mm², G04 case hardening steels >900N/mm², G05 heat treatable steels <1000N/mm², G06 heat treatable steels >900N/mm², G15 cast steels >900N/mm², G35 High strength structural steels fine grained

105/4 DUO RED RING
131/3 DUO RED RING
 G02 结构钢 >900N/mm², G04 表面硬化钢 >900N/mm², G05 热处理钢 <1000N/mm², G06 热处理钢 >900N/mm², G15 铸钢 >900N/mm², G35 高强度细晶粒结构钢

M

HSSE

HSSE-PM DUO

ISO 2 (6H)

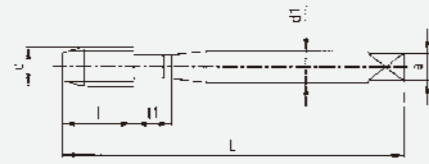

• For stock /有库存

Norm /标准



L	105/4		131/3		d ₁	a	d	P		Art.	Art.	Art.	Art.
	l	l ₁	l	l ₁									
46	11	7	6	11	4	3.2	M 3 0,5	2,5	J822519 ●			J878514 ●	
52	13	8	7.5	13	5	4	M 4 0,7	3,3	J822535 ●			J878530 ●	
60	16	9	9	16	5.5	4.5	M 5 0,8	4,2	J822543 ●			J878549 ●	
62	19	11	11	18	6	4.5	M 6 1	5	J822551 ●			J878557 ●	
70	22	13	13	21	6.2	5	M 8 1,25	6,8		J861123 ●			J878453 ●
75	24	15	16	22	7	5.5	M 10 1,5	8,5		J861131 ●			J878454 ●
82	29		18		8.5	6.5	M 12 1,75	10,2		J822594 ●			J878581 ●
88	30		20		10.5	8	M 14 2	12		J822608 ○			J878603 ○
95	32		20		12.5	10	M 16 2	14		J822616 ○			J878611 ○

● 标准库存品 ● Standard stock item

○ 非标准库存品, 直径 < 12mm, 最小起订量是200支; 直径 ≥ 12mm, 最小起订量是100支

○ Non-standard stock item, Diameter < 12 mm minimum order quantity is 200 pcs ; Diameter ≥ 12 minimum order quantity is 100 pcs

**105/4 YELLOW RING
131/3 YELLOW RING**

G20 Copper, G21 hard brass (Ms 58, short chipping), G22 soft brass (Ms 63, long chipping), G23 red brass, G24 phosphor bronze, G25 wrought alloy of aluminium, G29 wrought alloy of magnesium, G34 thermoplastic compounds/synthetics

**105/4 YELLOW RING
131/3 YELLOW RING**

G20 铜, G21 硬黄铜 (Ms 58, 短切屑), G22 软黄铜 (Ms 63, 长切屑), G23 红铜, G24 磷青铜, G25 锻造铝合金, G29 锻造镁合金, G34 热塑性复合材料/合成纤维

M

HSSE

HSSE-PM DUO

ISO 2 (6H)

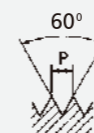
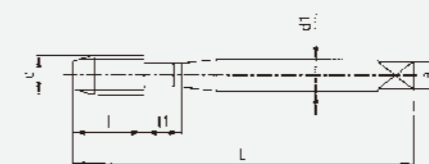

• For stock /有库存

Norm /标准



L	105/4		131/3		d ₁	a	d	P		Art.	Art.	Art.	Art.
	l	l ₁	l	l ₁									
46	11	7	6	11	4	3.2	M 3 0,5	2,5	J843403 ●			J843422 ●	
52	13	8	7.5	13	5	4	M 4 0,7	3,3	J843404 ●			J843423 ●	
60	16	9	9	16	5.5	4.5	M 5 0,8	4,2	J843405 ●			J843424 ●	
62	19	11	11	18	6	4.5	M 6 1	5	J843406 ●			J843425 ●	
70	22	13	13	21	6.2	5	M 8 1,25	6,8			J143414 ●		J143434 ●
75	24	15	16	22	7	5.5	M 10 1,5	8,5			J143415 ●		J143435 ●
82	29		18		8.5	6.5	M 12 1,75	10,2		J843409 ●			J843429 ●
88	30		20		10.5	8	M 14 2	12		J843410 ○			J843430 ○
95	32		20		12.5	10	M 16 2	14		J843411 ○			J843431 ○

● 标准库存品 ● Standard stock item

○ 非标准库存品, 直径 < 12mm, 最小起订量是200支; 直径 ≥ 12mm, 最小起订量是100支

○ Non-standard stock item, Diameter < 12 mm minimum order quantity is 200 pcs ; Diameter ≥ 12 minimum order quantity is 100 pcs

**105/4 DUO YELLOW RING
131/3 DUO YELLOW RING**

G20 Copper, G21 hard brass (Ms 58, short chipping), G22 soft brass (Ms 63, long chipping), G23 red brass, G24 phosphor bronze, G25 wrought alloy of aluminium, G29 wrought alloy of magnesium, G34 thermoplastic compounds/synthetics

**105/4 YELLOW RING DUO
131/3 YELLOW RING DUO**

G20 铜, G21 硬黄铜 (Ms 58, 短切屑), G22 软黄铜 (Ms 63, 长切屑), G23 红铜, G24 磷青铜, G25 锻造铝合金, G29 锻造镁合金, G34 热塑性复合材料/合成纤维

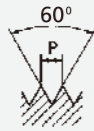
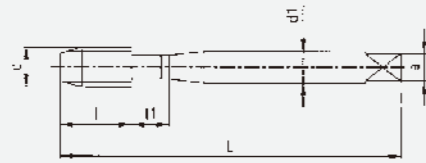
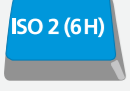

• For stock /有库存

Norm /标准

Norm /标准	105/4	105/4	131/3	131/3
	T-JIS	T-JIS	T-JIS	T-JIS
	ISO 2 (6H)	ISO 2 (6H)	ISO 2 (6H)	ISO 2 (6H)
	B/4	B/4	C/2,5	C/2,5

L	105/4		131/3		d ₁	a	d	P		Art.	Art.	Art.	Art.
	l	l ₁	l	l ₁									
	11	7	6	11	4	3.2	M 3 0,5	2,5	J856707 ●			J844245 ●	
52	13	8	7.5	13	5	4	M 4 0,7	3,3	J837176 ●			J845500 ●	
60	16	9	9	16	5.5	4.5	M 5 0,8	4,2	J837184 ●			J845659 ●	
62	19	11	11	18	6	4.5	M 6 1	5	J837192 ●			J851829 ●	
70	22	13	13	21	6.2	5	M 8 1,25	6,8		J852108 ●			J871625 ●
75	24	15	16	22	7	5.5	M 10 1,5	8,5		J852116 ●			J871633 ●
82	29		18		8.5	6.5	M 12 1,75	10,2		J837222 ●			J857150 ●
88	30		20		10.5	8	M 14 2	12		J837230 ○			J857177 ○
95	32		20		12.5	10	M 16 2			J837249 ○			J857193 ○

●标准库存品 ●Standard stock item

○非标准库存品,直径 < 12mm, 最小起订量是200支; 直径 ≥ 12mm, 最小起订量是100支

○Non-standard stock item, Diameter < 12 mm minimum order quantity is 200 pcs ; Diameter ≥ 12 minimum order quantity is 100 pcs

105/4,131/3 BLACK RING

G01 structural steels < 1000 N/mm², G03 case hardening steels < 1000 N/mm², G08 carbon tool steels, G10 Cr stainless, sulphured, G13 free-cutting steels, G14 cast steels < 1000 N/mm²

105/4,131/3 BLACK RING

G01 结构钢 < 1000 N/mm², G03 表面硬化钢 < 1000 N/mm², G08 碳素工具钢, G10 Cr 不锈钢, G13 易切钢, G14 铸钢 < 1000 N/mm²

105/4
DUO



T-JIS

ISO 2 (6H)

B/4

Art.

J843217 ●

J843218 ●

J843219 ●

J843220 ●

105/4
DUO



T-JIS

ISO 2 (6H)

B/4

Art.

J143229 ●

J143230 ●

J843232 ●

J843233 ○

J843234 ○

131/3
DUO



T-JIS

ISO 2 (6H)

C/2,5

Art.

J843239 ●

J843240 ●

J843241 ●

J843242 ●

131/3
DUO



T-JIS

ISO 2 (6H)

C/2,5

Art.

J143237 ●

J143238 ●

J843245 ●

J843246 ○

J843247 ○

●标准库存品 ●Standard stock item

○非标准库存品,直径 < 12mm, 最小起订量是200支; 直径 ≥ 12mm, 最小起订量是100支

○Non-standard stock item, Diameter < 12 mm minimum order quantity is 200 pcs ; Diameter ≥ 12 minimum order quantity is 100 pcs

105/4,131/3 DUO BLACK RING

G01 structural steels < 1000 N/mm², G03 case hardening steels < 1000 N/mm², G08 carbon tool steels, G10 Cr stainless, sulphured, G13 free-cutting steels, G14 cast steels < 1000 N/mm²

105/4,131/3 DUO BLACK RING

G01 结构钢 < 1000 N/mm², G03 表面硬化钢 < 1000 N/mm², G08 碳素工具钢, G10 Cr 不锈钢, G13 易切钢, G14 铸钢 < 1000 N/mm²

M

HSSE

HSSE-PM DUO

ISO 2 (6H)

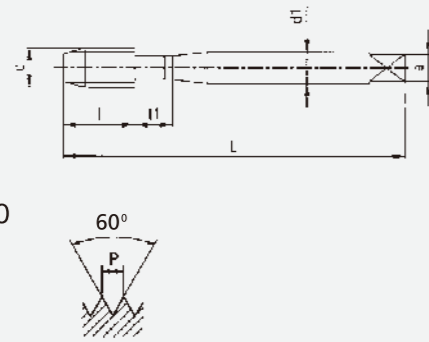

105/3



T-JIS

ISO 2 (6H)

C/2,5

105/3



T-JIS

ISO 2 (6H)

C/2,5

• For stock /有库存

Norm /标准



L	105/3							Art.	Art.
	l	l ₁	d ₁	a	d	P			
46	11	7	4	3.2	M 3 0,5	2,5	J837257 •		
52	13	8	5	4	M 4 0,7	3,3	J837273 •		
60	16	9	5.5	4.5	M 5 0,8	4,2	J837281 •		
62	19	11	6	4.5	M 6 1	5	J856715 •		
70	22	13	6.2	5	M 8 1,25	6,8		J871412 •	
75	24	15	7	5.5	M 10 1,5	8,5		J874985 •	
82	29		8.5	6.5	M 12 1,75	10,2		J856723 •	
95	30		12.5	10	M 16 2	12		J852140 ○	

● 标准库存品 ● Standard stock item

○ 非标准库存品, 直径 < 12mm, 最小起订量是200支; 直径 ≥ 12mm, 最小起订量是100支

○ Non-standard stock item, Diameter < 12 mm minimum order quantity is 200 pcs ; Diameter ≥ 12 minimum order quantity is 100 pcs

105/3 GREEN RING

G16 malleable cast iron, G17 nodular graphite cast iron, G18 lamellar graphite cast iron (grey cast iron), G19 vermicular graphite cast iron, G26 aluminium cast alloy Si 0.5% - 5%, G27 aluminium cast alloy Si 5% - 10%, G28 aluminium cast alloy Si > 10%, G30 cast alloy of magnesium, G33 ferro-TiC

105/3 GREEN RING

G16 可锻铸铁, G17 结节性石墨铸铁 (球磨铸铁), G18 片状石墨铸铁 (灰铸铁), G19 蠕墨铸铁, G26 铸造铝合金 Si 0.5% - 5%, G27 铸造铝合金 Si 5% - 10%, G28 铸造铝合金 Si > 10%, G30 铸造镁合金, G33 铁-TiC钢结硬质合金

M

HSSE

HSSE-PM DUO

ISO 2 (6H)

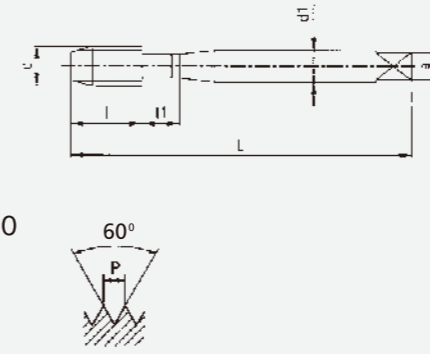

105/3



T-JIS

ISO 2 (6H)

C/2,5

105/3



T-JIS

ISO 2 (6H)

C/2,5

• For stock /有库存

Norm /标准



L	105/3							Art.	Art.
	l	l ₁	d ₁	a	d	P			
46	11	7	4	3.2	M 3 0,5	2,5	J843446 •		
52	13	8	5	4	M 4 0,7	3,3	J843447 •		
60	16	9	5.5	4.5	M 5 0,8	4,2	J843448 •		
62	19	11	6	4.5	M 6 1	5	J843449 •		
70	22	13	6.2	5	M 8 1,25	6,8		J143450 •	
75	24	15	7	5.5	M 10 1,5	8,5		J143451 •	
82	29		8.5	6.5	M 12 1,75	10,2		J843454 •	
95	30		12.5	10	M 16 2	12		J843456 ○	

● 标准库存品 ● Standard stock item

○ 非标准库存品, 直径 < 12mm, 最小起订量是200支; 直径 ≥ 12mm, 最小起订量是100支

○ Non-standard stock item, Diameter < 12 mm minimum order quantity is 200 pcs ; Diameter ≥ 12 minimum order quantity is 100 pcs

105/3 DUO GREEN RING

G16 malleable cast iron, G17 nodular graphite cast iron, G18 lamellar graphite cast iron (grey cast iron), G19 vermicular graphite cast iron, G26 aluminium cast alloy Si 0.5% - 5%, G27 aluminium cast alloy Si 5% - 10%, G28 aluminium cast alloy Si > 10%, G30 cast alloy of magnesium, G33 ferro-TiC

105/3 DUO GREEN RING

G16 可锻铸铁, G17 结节性石墨铸铁 (球磨铸铁), G18 片状石墨铸铁 (灰铸铁), G19 蠕墨铸铁, G26 铸造铝合金 Si 0.5% - 5%, G27 铸造铝合金 Si 5% - 10%, G28 铸造铝合金 Si > 10%, G30 铸造镁合金, G33 铁-TiC钢结硬质合金

<p>• For stock /有库存</p>																																																																																																																																																										
<p>Norm /标准</p>																																																																																																																																																										
<table border="1"> <thead> <tr> <th rowspan="2">L</th> <th colspan="2">105/4</th> <th colspan="2">131/3</th> <th rowspan="2">d₁</th> <th rowspan="2">a</th> <th rowspan="2">d</th> <th rowspan="2">p</th> <th rowspan="2"></th> <th rowspan="2">Art.</th> <th rowspan="2">Art.</th> <th rowspan="2">Art.</th> <th rowspan="2">Art.</th> </tr> <tr> <th>l</th> <th>l₁</th> <th>l</th> <th>l₁</th> </tr> </thead> <tbody> <tr> <td>46</td> <td>11</td> <td>7</td> <td>6</td> <td>11</td> <td>4</td> <td>3,2</td> <td>M 3</td> <td>0,5</td> <td>2,5</td> <td>J893572 ●</td> <td></td> <td>J825925 ●</td> <td></td> </tr> <tr> <td>52</td> <td>13</td> <td>8</td> <td>7.5</td> <td>13</td> <td>5</td> <td>4</td> <td>M 4</td> <td>0,7</td> <td>3,3</td> <td>J893580 ●</td> <td></td> <td>J826034 ●</td> <td></td> </tr> <tr> <td>60</td> <td>16</td> <td>9</td> <td>9</td> <td>16</td> <td>5,5</td> <td>4,5</td> <td>M 5</td> <td>0,8</td> <td>4,2</td> <td>J893599 ●</td> <td></td> <td>J826085 ●</td> <td></td> </tr> <tr> <td>62</td> <td>19</td> <td>11</td> <td>11</td> <td>18</td> <td>6</td> <td>4,5</td> <td>M 6</td> <td>1</td> <td>5</td> <td>J893602 ●</td> <td></td> <td>J826123 ●</td> <td></td> </tr> <tr> <td>70</td> <td>22</td> <td>13</td> <td>13</td> <td>21</td> <td>6,2</td> <td>5</td> <td>M 8</td> <td>1,25</td> <td>6,8</td> <td></td> <td>J193631 ●</td> <td></td> <td>J126291 ●</td> </tr> <tr> <td>75</td> <td>24</td> <td>15</td> <td>16</td> <td>22</td> <td>7</td> <td>5,5</td> <td>M 10</td> <td>1,5</td> <td>8,5</td> <td></td> <td>J193632 ●</td> <td></td> <td>J126292 ●</td> </tr> <tr> <td>82</td> <td>29</td> <td></td> <td>18</td> <td></td> <td>8,5</td> <td>6,5</td> <td>M 12</td> <td>1,75</td> <td>10,2</td> <td></td> <td>J893637 ●</td> <td></td> <td>J826298 ●</td> </tr> <tr> <td>88</td> <td>30</td> <td></td> <td>20</td> <td></td> <td>10,5</td> <td>8</td> <td>M 14</td> <td>2</td> <td>12</td> <td></td> <td>J893645 ○</td> <td></td> <td>J854852 ○</td> </tr> <tr> <td>95</td> <td>32</td> <td></td> <td>20</td> <td></td> <td>12,5</td> <td>10</td> <td>M 16</td> <td>2</td> <td>14</td> <td></td> <td>J893653 ○</td> <td></td> <td>J854860 ○</td> </tr> </tbody> </table>											L	105/4		131/3		d ₁	a	d	p		Art.	Art.	Art.	Art.	l	l ₁	l	l ₁	46	11	7	6	11	4	3,2	M 3	0,5	2,5	J893572 ●		J825925 ●		52	13	8	7.5	13	5	4	M 4	0,7	3,3	J893580 ●		J826034 ●		60	16	9	9	16	5,5	4,5	M 5	0,8	4,2	J893599 ●		J826085 ●		62	19	11	11	18	6	4,5	M 6	1	5	J893602 ●		J826123 ●		70	22	13	13	21	6,2	5	M 8	1,25	6,8		J193631 ●		J126291 ●	75	24	15	16	22	7	5,5	M 10	1,5	8,5		J193632 ●		J126292 ●	82	29		18		8,5	6,5	M 12	1,75	10,2		J893637 ●		J826298 ●	88	30		20		10,5	8	M 14	2	12		J893645 ○		J854852 ○	95	32		20		12,5	10	M 16	2	14		J893653 ○		J854860 ○
L	105/4		131/3		d ₁	a	d	p		Art.		Art.	Art.	Art.																																																																																																																																												
	l	l ₁	l	l ₁																																																																																																																																																						
46	11	7	6	11	4	3,2	M 3	0,5	2,5	J893572 ●		J825925 ●																																																																																																																																														
52	13	8	7.5	13	5	4	M 4	0,7	3,3	J893580 ●		J826034 ●																																																																																																																																														
60	16	9	9	16	5,5	4,5	M 5	0,8	4,2	J893599 ●		J826085 ●																																																																																																																																														
62	19	11	11	18	6	4,5	M 6	1	5	J893602 ●		J826123 ●																																																																																																																																														
70	22	13	13	21	6,2	5	M 8	1,25	6,8		J193631 ●		J126291 ●																																																																																																																																													
75	24	15	16	22	7	5,5	M 10	1,5	8,5		J193632 ●		J126292 ●																																																																																																																																													
82	29		18		8,5	6,5	M 12	1,75	10,2		J893637 ●		J826298 ●																																																																																																																																													
88	30		20		10,5	8	M 14	2	12		J893645 ○		J854852 ○																																																																																																																																													
95	32		20		12,5	10	M 16	2	14		J893653 ○		J854860 ○																																																																																																																																													

● 标准库存品 ● Standard stock item
 ○ 非标准库存品,直径 < 12mm, 最小起订量是200支; 直径 ≥ 12mm, 最小起订量是100支
 ○ Non-standard stock item, Diameter < 12 mm minimum order quantity is 200 pcs ; Diameter ≥ 12 minimum order quantity is 100 pcs

105/4,131/3 BLUE RING

G07 nitriding steels,G09 heat resisting steels,G11 Cr stainless steels,ferritic and martensitic,G12 Cr-Ni stainless steels,austenitic, G31 alloy of nickel,G32 titanium and alloy of titanium

105/4,131/3 BLUE RING

G07 氮化钢,G09 耐热钢,G11 Cr 不锈钢,铁素体不锈钢和马氏体不锈钢,G12 Cr-Ni 不锈钢,奥氏体不锈钢, G31 镍合金, G32 钛和钛合金

<p>• 标准库存品 ● Standard stock item</p>																																																																																																																																																			
<p>Norm /标准</p>																																																																																																																																																			
<table border="1"> <thead> <tr> <th rowspan="2">L</th> <th colspan="2">105/4 DUO</th> <th colspan="2">131/3 DUO</th> <th rowspan="2">d₁</th> <th rowspan="2">a</th> <th rowspan="2">d</th> <th rowspan="2">p</th> <th rowspan="2"></th> <th rowspan="2">Art.</th> <th rowspan="2">Art.</th> <th rowspan="2">Art.</th> <th rowspan="2">Art.</th> </tr> <tr> <th>l</th> <th>l₁</th> <th>l</th> <th>l₁</th> </tr> </thead> <tbody> <tr> <td>46</td> <td>11</td> <td>7</td> <td>6</td> <td>11</td> <td>4</td> <td>3,2</td> <td>M 3</td> <td>0,5</td> <td>2,5</td> <td>J843285 ●</td> <td></td> <td>J843299 ●</td> <td></td> </tr> <tr> <td>52</td> <td>13</td> <td>8</td> <td>7.5</td> <td>13</td> <td>5</td> <td>4</td> <td>M 4</td> <td>0,7</td> <td>3,3</td> <td>J843286 ●</td> <td></td> <td>J843300 ●</td> <td></td> </tr> <tr> <td>60</td> <td>16</td> <td>9</td> <td>9</td> <td>16</td> <td>5,5</td> <td>4,5</td> <td>M 5</td> <td>0,8</td> <td>4,2</td> <td>J843287 ●</td> <td></td> <td>J843301 ●</td> <td></td> </tr> <tr> <td>62</td> <td>19</td> <td>11</td> <td>11</td> <td>18</td> <td>6</td> <td>4,5</td> <td>M 6</td> <td>1</td> <td>5</td> <td>J843289 ●</td> <td></td> <td>J843302 ●</td> <td></td> </tr> <tr> <td>70</td> <td>22</td> <td>13</td> <td>13</td> <td>21</td> <td>6,2</td> <td>5</td> <td>M 8</td> <td>1,25</td> <td>6,8</td> <td></td> <td>J143281 ●</td> <td></td> <td>J143297 ●</td> </tr> <tr> <td>75</td> <td>24</td> <td>15</td> <td>16</td> <td>22</td> <td>7</td> <td>5,5</td> <td>M 10</td> <td>1,5</td> <td>8,5</td> <td></td> <td>J143282 ●</td> <td></td> <td>J143298 ●</td> </tr> <tr> <td>82</td> <td>29</td> <td></td> <td>18</td> <td></td> <td>8,5</td> <td>6,5</td> <td>M 12</td> <td>1,75</td> <td>10,2</td> <td></td> <td>J843292 ●</td> <td></td> <td>J843306 ●</td> </tr> <tr> <td>88</td> <td>30</td> <td></td> <td>20</td> <td></td> <td>10,5</td> <td>8</td> <td>M 14</td> <td>2</td> <td>12</td> <td></td> <td>J843293 ○</td> <td></td> <td>J843307 ○</td> </tr> <tr> <td>95</td> <td>32</td> <td></td> <td>20</td> <td></td> <td>12,5</td> <td>10</td> <td>M 16</td> <td>2</td> <td>14</td> <td></td> <td>J843294 ○</td> <td></td> <td>J843308 ○</td> </tr> </tbody> </table>				L	105/4 DUO		131/3 DUO		d ₁	a	d	p		Art.	Art.	Art.	Art.	l	l ₁	l	l ₁	46	11	7	6	11	4	3,2	M 3	0,5	2,5	J843285 ●		J843299 ●		52	13	8	7.5	13	5	4	M 4	0,7	3,3	J843286 ●		J843300 ●		60	16	9	9	16	5,5	4,5	M 5	0,8	4,2	J843287 ●		J843301 ●		62	19	11	11	18	6	4,5	M 6	1	5	J843289 ●		J843302 ●		70	22	13	13	21	6,2	5	M 8	1,25	6,8		J143281 ●		J143297 ●	75	24	15	16	22	7	5,5	M 10	1,5	8,5		J143282 ●		J143298 ●	82	29		18		8,5	6,5	M 12	1,75	10,2		J843292 ●		J843306 ●	88	30		20		10,5	8	M 14	2	12		J843293 ○		J843307 ○	95	32		20		12,5	10	M 16	2	14		J843294 ○		J843308 ○
L	105/4 DUO		131/3 DUO		d ₁	a	d	p											Art.	Art.	Art.	Art.																																																																																																																													
	l	l ₁	l	l ₁																																																																																																																																															
46	11	7	6	11	4	3,2	M 3	0,5	2,5	J843285 ●		J843299 ●																																																																																																																																							
52	13	8	7.5	13	5	4	M 4	0,7	3,3	J843286 ●		J843300 ●																																																																																																																																							
60	16	9	9	16	5,5	4,5	M 5	0,8	4,2	J843287 ●		J843301 ●																																																																																																																																							
62	19	11	11	18	6	4,5	M 6	1	5	J843289 ●		J843302 ●																																																																																																																																							
70	22	13	13	21	6,2	5	M 8	1,25	6,8		J143281 ●		J143297 ●																																																																																																																																						
75	24	15	16	22	7	5,5	M 10	1,5	8,5		J143282 ●		J143298 ●																																																																																																																																						
82	29		18		8,5	6,5	M 12	1,75	10,2		J843292 ●		J843306 ●																																																																																																																																						
88	30		20		10,5	8	M 14	2	12		J843293 ○		J843307 ○																																																																																																																																						
95	32		20		12,5	10	M 16	2	14		J843294 ○		J843308 ○																																																																																																																																						

● 标准库存品 ● Standard stock item
 ○ 非标准库存品,直径 < 12mm, 最小起订量是200支; 直径 ≥ 12mm, 最小起订量是100支
 ○ Non-standard stock item, Diameter < 12 mm minimum order quantity is 200 pcs ; Diameter ≥ 12 minimum order quantity is 100 pcs

105/4, 131/3 DUO BLUE RING

G07 nitriding steels,G09 heat resisting steels,G11 Cr stainless steels,ferritic and martensitic,G12 Cr-Ni stainless steels,austenitic, G31 alloy of nickel,G32 titanium and alloy of titanium

105/4, 131/3 DUO BLUE RING

G07 氮化钢,G09 耐热钢,G11 Cr 不锈钢,铁素体不锈钢和马氏体不锈钢,G12 Cr-Ni 不锈钢,奥氏体不锈钢, G31 镍合金, G32 钛和钛合金

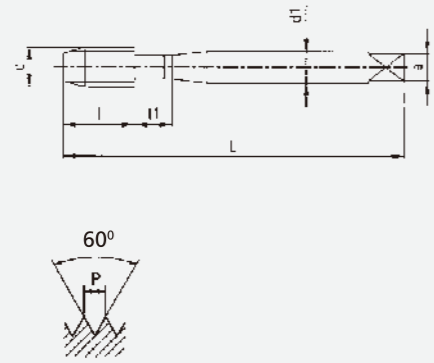
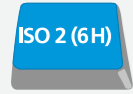

● For stock /有库存

Norm /标准	105/4	105/4	131/3	131/3
	T-JIS	T-JIS	T-JIS	T-JIS
	ISO 2 (6H)	ISO 2 (6H)		
	B/4	B/4	C/2,5	C/2,5

L	105/4		131/3		d ₁	a	d	P		Art.	Art.	Art.	Art.
	l	l _i	l	l _i									
46	11	7	6	11	4	3.2	M 3 0,5	2,5	J875035 ●			J876031 ●	
52	13	8	7.5	13	5	4	M 4 0,7	3,3	J875043 ●			J876058 ●	
60	16	9	9	16	5.5	4.5	M 5 0,8	4,2	J875051 ●			J876066 ●	
62	19	11	11	18	6	4.5	M 6 1	5	J875078 ●			J876074 ●	
70	22	13	13	21	6.2	5	M 8 1,25	6,8		J175092 ●			J176088 ●
75	24	15	16	22	7	5.5	M 10 1,5	8,5		J175100 ●			J176096 ●
82	29		18		8.5	6.5	M 12 1,75	10,2		J875108 ●			J876104 ●
88	30		48		10.5	8	M 14 2	12		J875116 ○			J876112 ○
95	32		20		12.5	10	M 16 2	14		J875124 ○			J876120 ○

● 标准库存品 ● Standard stock item

○ 非标准库存品, 直径 < 12mm, 最小起订量是200支; 直径 ≥ 12mm, 最小起订量是100支

○ Non-standard stock item, Diameter < 12 mm minimum order quantity is 200 pcs ; Diameter ≥ 12 minimum order quantity is 100 pcs

105/4 RED RING 131/3 RED RING

G02 structural steels > 900N/mm², G04 case hardening steels > 900N/mm², G05 heat treatable steels < 1000N/mm², G06 heat treatable steels > 900N/mm², G15 cast steels > 900N/mm², G35 High strength structural steels fine grained

105/4 RED RING 131/3 RED RING

G02 结构钢 > 900N/mm², G04 表面硬化钢 > 900N/mm², G05 热处理钢 < 1000N/mm², G06 热处理钢 > 900N/mm², G15 铸钢 > 900N/mm², G35 高强度细晶粒结构钢

105/4
DUO

T-JIS

ISO 2 (6H)

B/4

Art.

J843314 ●

J843315 ●

J843316 ●

J843317 ●

105/4
DUO

T-JIS

ISO 2 (6H)

B/4

Art.

J143311 ●

J143312 ●

J843320 ●

J843321 ○

J843322 ○

131/3
DUO

T-JIS

ISO 2 (6H)

C/2,5

Art.

J843327 ●

J843328 ●

J843329 ●

J843330 ●

131/3
DUO

T-JIS

ISO 2 (6H)

C/2,5

Art.

J143325 ●

J143326 ●

J843333 ●

J843334 ○

J843335 ○

105/4 DUO RED RING 131/3 DUO RED RING

G02 structural steels > 900N/mm², G04 case hardening steels > 900N/mm², G05 heat treatable steels < 1000N/mm², G06 heat treatable steels > 900N/mm², G15 cast steels > 900N/mm², G35 High strength structural steels fine grained

105/4 DUO RED RING 131/3 DUO RED RING

G02 结构钢 > 900N/mm², G04 表面硬化钢 > 900N/mm², G05 热处理钢 < 1000N/mm², G06 热处理钢 > 900N/mm², G15 铸钢 > 900N/mm², G35 高强度细晶粒结构钢

MF DIN 374

HSSE

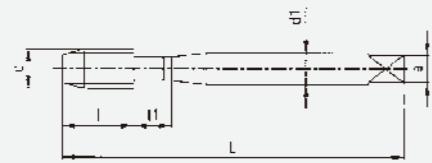

ISO 2 (6H)

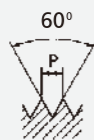

• For stock /有库存

Norm /标准
Class of tolerance /公差



105/4

131/3



DIN 374	DIN 374
ISO 2 (6H)	ISO 2 (6H)
B/4	C/2,5

L	105/4		131/3		d ₁	a	d	P		Art.	Art.
	l	l	l	l							
63	10	7.5	2.8	2.1	MF4	0,5	3,5	C864170	○	C865600	○
70	12	7.5	3.5	2.7	MF5	0,5	4,5	C864171	○	C865601	○
80	14	8	4.5	3.4	MF6	0,5	5,5	C864173	○	C865603	○
80	14	8	4.5	3.4	MF6	0,75	5,25	C864174	○	C865604	○
80	17	10	6	4.9	MF8	0,5	7,5	C864175	○	C865605	○
80	18	10	6	4.9	MF8	0,75	7,25	C864176	○	C865606	○
90	22	10	6	4.9	MF8	1	7	C864177	○	C865607	○
90	17	12	7	5.5	MF10	0,5	9,5	C864178	○	C865608	○
90	20	12	7	5.5	MF10	0,75	9,25	C864179	○	C865609	○
90	20	12	7	5.5	MF10	1	9	C864180	○	C865610	○
100	24	14	7	5.5	MF10	1,25	8,8	C864181	○	C865611	○
100	22	14	9	7	MF12	1	11	C864183	○	C865613	○
100	22	14	9	7	MF12	1,25	10,8	C864184	○	C865614	○
100	22	14	9	7	MF12	1,5	10,5	C864185	○	C865615	○
100	22	16	11	9	MF14	1	13	C864186	○	C865616	○
100	22	20	11	9	MF14	1,5	12,5	C864187	○	C865617	○

● 标准库存品 ● Standard stock item
○ 非标准库存品, 直径 < 12mm, 最小起订量是200支; 直径 ≥ 12mm, 最小起订量是100支
○ Non-standard stock item, Diameter < 12 mm minimum order quantity is 200 pcs ; Diameter ≥ 12 minimum order quantity is 100 pcs

**105/4 YELLOW RING
131/3 YELLOW RING**

G20 Copper, G21 hard brass (Ms 58, short chipping), G22 soft brass (Ms 63, long chipping), G23 red brass, G24 phosphor bronze, G25 wrought alloy of aluminium, G29 wrought alloy of magnesium, G34 thermoplastic compounds/synthetics

**105/4 YELLOW RING
131/3 YELLOW RING**

G20 铜, G21 硬黄铜 (Ms 58, 短切削), G22 软黄铜 (Ms 63, 长切削), G23 红铜, G24 磷青铜, G25 锻造铝合金, G29 锻造镁合金, G34 热塑性复合材料/合成纤维

MF DIN 374

HSSE

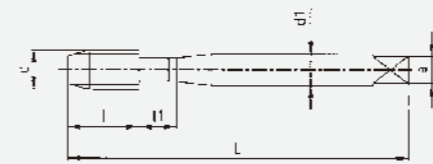

ISO 2 (6H)



• For stock /有库存

Norm /标准
Class of tolerance /公差



105/4

131/3



DIN 374	DIN 374
ISO 2 (6H)	ISO 2 (6H)
B/4	C/2,5

L	105/4		131/3		d ₁	a	d	P		Art.	Art.
	l	l	l	l							
63	10	7.5	2.8	2.1	MF4	0,5	3,5	C866300	○	C866600	○
70	12	7.5	3.5	2.7	MF5	0,5	4,5	C866301	○	C866601	○
80	14	8	4.5	3.4	MF6	0,5	5,5	C866302	○	C866603	○
80	14	8	4.5	3.4	MF6	0,75	5,25	C866303	○	C866604	○
80	17	10	6	4.9	MF8	0,5	7,5	C866304	○	C866605	○
80	18	10	6	4.9	MF8	0,75	7,25	C866305	○	C866606	○
90	22	10	6	4.9	MF8	1	7	C866306	○	C866607	○
90	17	12	7	5.5	MF10	0,5	9,5	C866307	○	C866608	○
90	20	12	7	5.5	MF10	0,75	9,25	C866308	○	C866609	○
90	20	12	7	5.5	MF10	1	9	C866309	○	C866610	○
90	24	14	7	5.5	MF10	1,25	8,8	C866310	○	C866611	○
100	22	14	9	7	MF12	1	11	C866311	○	C866613	○
100	22	14	9	7	MF12	1,25	10,8	C866312	○	C866614	○
100	22	14	9	7	MF12	1,5	10,5	C866313	○	C866615	○
100	22	16	11	9	MF14	1	13	C866314	○	C866616	○
100	22	20	11	9	MF14	1,5	12,5	C866315	○	C866617	○

● 标准库存品 ● Standard stock item
○ 非标准库存品, 直径 < 12mm, 最小起订量是200支; 直径 ≥ 12mm, 最小起订量是100支
○ Non-standard stock item, Diameter < 12 mm minimum order quantity is 200 pcs ; Diameter ≥ 12 minimum order quantity is 100 pcs

105/4, 131/3 BLACK RING

G01 structural steels < 1000 N/mm², G03 case hardening steels < 1000 N/mm², G08 carbon tool steels, G10 Cr stainless, sulphured, G13 free-cutting steels, G14 cast steels < 1000 N/mm²

105/4, 131/3 BLACK RING

G01 结构钢 < 1000 N/mm², G03 表面硬化钢 < 1000 N/mm², G08 碳素工具钢, G10 Cr 不锈钢, G13 易切钢, G14 铸钢 < 1000 N/mm²



DIN 374

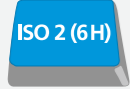
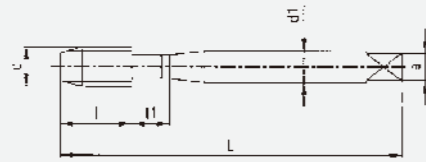

• For stock /有库存

Norm /标准
Class of tolerance /公差



105/3



DIN 374
ISO 2 (6H)
C/2,5

L	l	d ₁	a	d	P		Art.
63	10	2.8	2.1	MF4	0,5		C866700 ○
70	12	3.5	2.7	MF5	0,5		C866701 ○
80	14	4.5	3.4	MF6	0,75		C866702 ○
80	18	6	4.9	MF8	0,75		C866703 ○
90	22	6	4.9	MF8	1		C866704 ○
90	20	7	5.5	MF10	1		C866705 ○
100	22	9	7	MF12	1		C866706 ○
100	22	9	7	MF12	1,5		C866707 ○
100	22	11	9	MF14	1,5		C866708 ○

● 标准库存品 ● Standard stock item
○ 非标准库存品, 直径 < 12mm, 最小起订量是200支; 直径 ≥ 12mm, 最小起订量是100支
○ Non-standard stock item, Diameter < 12 mm minimum order quantity is 200 pcs ; Diameter ≥ 12 minimum order quantity is 100 pcs

105/3 GREEN RING

G16 malleable cast iron, G17 nodular graphite cast iron, G18 lamellar graphite cast iron (grey cast iron), G19 vermicular graphite cast iron, G26 aluminium cast alloy Si 0.5% - 5%, G27 aluminium cast alloy Si 5% - 10%, G28 aluminium cast alloy Si > 10%, G30 cast alloy of magnesium, G33 ferro-TiC

105/3 GREEN RING

G16 可锻铸铁, G17 结节性石墨铸铁 (球磨铸铁), G18 片状石墨铸铁 (灰铸铁), G19 蠕墨铸铁, G26 铸造铝合金 Si 0.5% - 5%, G27 铸造铝合金 Si 5% - 10%, G28 铸造铝合金 Si > 10%, G30 铸造镁合金, G33 ferro-TiC 钢结硬质合金



DIN 371/374

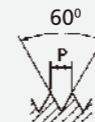
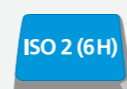
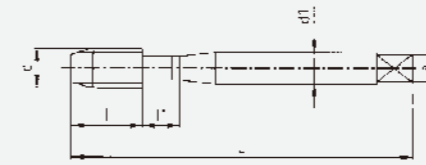

• For stock /有库存

Norm /标准
Class of tolerance /公差



105/4

105/4

131/3

131/3



DIN 371 DIN 374 DIN 371 DIN 374
ISO 2 (6H) ISO 2 (6H) ISO 2 (6H) ISO 2 (6H)
B/4 B/4 C/2,5 C/2,5

L	105/4		131/3		d ₁	a	d	p		Art.	Art.	Art.	Art.
	l	l ₁	l	l ₁									
63	10	8	7.5	13	4.5	3.4	MF4	0,5	3,5	C811870 ○		C884875 ○	
70	12	11	7.5	16	6	4.9	MF5	0,5	4,5	C811871 ○		C884883 ○	
80	14	11	8	18	6	4.9	MF6	0,75	5,25	C811872 ○		C884891 ○	
80	18	13	10	21	8	6.2	MF8	0,75	7,25	C811873 ○		C884905 ○	
90	22	13	10	21	8	6.2	MF8	1	7	C811874 ○		C884913 ○	
90	20	15	12	22	10	8	MF10	0,75	9,25	C811875 ○		C884921 ○	
90	20	15	12	22	10	8	MF10	1	9	C811876 ○		C884948 ○	
100	24	15	14		10	8	MF10	1,25	8,8	C812350 ○		C812352 ○	
100	22		14		9	7	MF12	1	11		C811877 ○		C884956 ○
100	22		14		9	7	MF12	1,25	10,8		C811879 ○		C884964 ○
100	22		14		9	7	MF12	1,5	10,5		C811880 ○		C884972 ○
100	22		16		11	9	MF14	1	13		C811881 ○		C884980 ○
100	22		20		11	9	MF14	1,5	12,5		C811882 ○		C884999 ○

● 标准库存品 ● Standard stock item
○ 非标准库存品, 直径 < 12mm, 最小起订量是200支; 直径 ≥ 12mm, 最小起订量是100支
○ Non-standard stock item, Diameter < 12 mm minimum order quantity is 200 pcs ; Diameter ≥ 12 minimum order quantity is 100 pcs

105/4,131/3 BLUE RING

G07 nitriding steels, G09 heat resisting steels, G11 Cr stainless steels, ferritic and martensitic, G12 Cr-Ni stainless steels, austenitic, G31 alloy of nickel, G32 titanium and alloy of titanium

105/4,131/3 BLUE RING

G07 氮化钢, G09 耐热钢, G11 Cr 不锈钢, 铁素体不锈钢和马氏体不锈钢, G12 Cr-Ni 不锈钢, 奥氏体不锈钢, G31 镍合金, G32 钛和钛合金



DIN 371/374

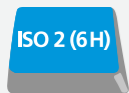
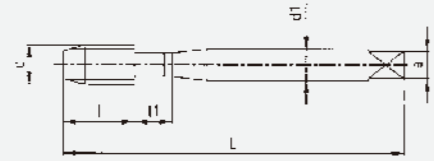

• For stock /有库存

Norm /标准	DIN 371	DIN 374	DIN 371	DIN 374
Class of tolerance /公差	ISO 2 (6H)	ISO 2 (6H)	ISO 2 (6H)	ISO 2 (6H)
	B/4	B/4	C/2,5	C/2,5

L	105/4		131/3		d ₁	a	d	p	P	Art.	Art.	Art.	Art.
	l	l ₁	l	l ₁									
63	10	8	7.5	13	4.5	3.4	MF4	0,5	3,5	C885065 ○		C887610 ○	
70	12	11	7.5	16	6	4.9	MF5	0,5	4,5	C885073 ○		C887629 ○	
80	14	11	8	18	6	4.9	MF6	0,75	5,25	C885081 ○		C887637 ○	
80	18	13	10	21	8	6.2	MF8	0,75	7,25	C885103 ○		C887645 ○	
90	22	13	10	21	8	6.2	MF8	1	7	C885111 ○		C887653 ○	
90	20	15	12	22	10	8	MF10	0,75	9,25	C885138 ○		C887661 ○	
90	20	15	12	22	10	8	MF10	1	9	C885146 ○		C887688 ○	
100	22		14		9	7	MF12	1	11		C885154 ○		C887696 ○
100	22		14		9	7	MF12	1,25	10,8		C885162 ○		C887718 ○
100	22		14		9	7	MF12	1,5	10,5		C885170 ○		C887726 ○
100	22		16		11	9	MF14	1	13		C885189 ○		C887734 ○
100	22		20		11	9	MF14	1,5	12,5		C885197 ○		C887742 ○

● 标准库存品 ● Standard stock item
 ○ 非标准库存品, 直径 < 12mm, 最小起订量是200支; 直径 ≥ 12mm, 最小起订量是100支
 ○ Non-standard stock item, Diameter < 12 mm minimum order quantity is 200 pcs ; Diameter ≥ 12 minimum order quantity is 100 pcs

**105/4 RED RING
131/3 RED RING**

G02 structural steels >900N/mm², G04 case hardening steels >900N/mm², G05 heat treatable steels <1000N/mm², G06 heat treatable steels >900N/mm², G15 cast steels >900N/mm², G35 High strength structural steels fine grained

**105/4 RED RING
131/3 RED RING**

G02 结构钢 >900N/mm², G04 表面硬化钢 >900N/mm², G05 热处理钢 <1000N/mm², G06 热处理钢 >900N/mm², G15 铸钢 >900N/mm², G35 高强度细晶粒结构钢



105/4 105/4 131/3 131/3

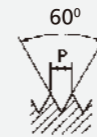
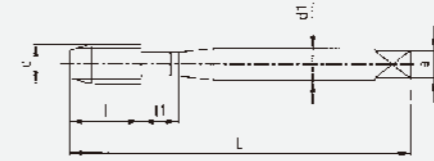

• For stock /有库存

Norm /标准	T-JIS	T-JIS	T-JIS	T-JIS
	ISO 2 (6H)	ISO 2 (6H)	ISO 2 (6H)	ISO 2 (6H)
	B/4	B/4	C/2,5	C/2,5

L	105/4		131/3		d ₁	a	d	p	P	Art.	Art.	Art.	Art.
	l	l ₁	l	l ₁									
52	10	8	7.5	13	5	4	MF4	0,5	3,5	J885065 ○		J887610 ○	
60	12	11	7.5	16	5.5	4.5	MF5	0,5	4,5	J885073 ○		J887629 ○	
62	14	11	8	18	6	4.5	MF6	0,75	5,25	J885081 ○		J887637 ○	
70	18	13	10	21	6.2	5	MF8	0,75	7,25		J185148 ○		J187690 ○
70	22	13	10	21	6.2	5	MF8	1	7		J185149 ○		J187691 ○
75	20	15	12	22	7	5.5	MF10	0,75	9,25		J185150 ○		J187692 ○
75	20	15	12	22	7	5.5	MF10	1	9		J185152 ○		J187693 ○
82	22		14		8.5	6.5	MF12	1	11		J885154 ○		J887696 ○
82	22		14		8.5	6.5	MF12	1,25	10,8		J885162 ○		J887718 ○
82	22		14		8.5	6.5	MF12	1,5	10,5		J885170 ○		J887726 ○
88	22		16		10.5	8	MF14	1	13		J885189 ○		J887734 ○
88	22		20		10.5	8	MF14	1,5	12,5		J885197 ○		J887742 ○
95	22		16		12.5	10	MF16	1	15		J885200 ○		J887750 ○
95	22		20		12.5	10	MF16	1,5	14,5		J885219 ○		J887769 ○

● 标准库存品 ● Standard stock item
 ○ 非标准库存品, 直径 < 12mm, 最小起订量是200支; 直径 ≥ 12mm, 最小起订量是100支
 ○ Non-standard stock item, Diameter < 12 mm minimum order quantity is 200 pcs ; Diameter ≥ 12 minimum order quantity is 100 pcs

**105/4 RED RING
131/3 RED RING**

G02 structural steels >900N/mm², G04 case hardening steels >900N/mm², G05 heat treatable steels <1000N/mm², G06 heat treatable steels >900N/mm², G15 cast steels >900N/mm², G35 High strength structural steels fine grained

**105/4 RED RING
131/3 RED RING**

G02 结构钢 >900N/mm², G04 表面硬化钢 >900N/mm², G05 热处理钢 <1000N/mm², G06 热处理钢 >900N/mm², G15 铸钢 >900N/mm², G35 高强度细晶粒结构钢

MF

HSSE

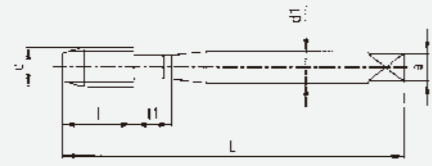

• For stock /有库存

Norm /标准



L	105/4		131/3		d ₁	a	d	P	Art.	Art.
	l	l	l	l						
52	10	7.5	5	4	MF4	0.5	3.5	J864170 ○	J865600 ○	
60	12	7.5	5.5	4.5	MF5	0.5	4.5	J864171 ○	J865601 ○	
62	14	8	6	4.5	MF6	0.75	5.25	J864174 ○	J865604 ○	
70	18	10	6.2	5	MF8	0.75	7.25	J164218 ○	J165641 ○	
70	22	10	6.2	5	MF8	1	7	J164219 ○	J165642 ○	
75	20	12	7	5.5	MF10	0.75	9.25	J164220 ○	J165643 ○	
75	20	12	7	5.5	MF10	1	9	J164221 ○	J165644 ○	
75	24	14	7	5.5	MF10	1.25	8.8	J164222 ○	J165645 ○	
82	22	14	8.5	6.5	MF12	1	11	J164223 ○	J165646 ○	
82	22	14	8.5	6.5	MF12	1.25	10.8	J164224 ○	J165647 ○	
82	22	14	8.5	6.5	MF12	1.5	10.5	J164225 ○	J165648 ○	
88	22	16	10.5	8	MF14	1	13	J164226 ○	J165649 ○	
88	22	20	10.5	8	MF14	1.5	12.5	J164227 ○	J165650 ○	
95	22	16	12.5	10	MF16	1	15	J164228 ○	J165651 ○	
95	22	20	12.5	10	MF16	1.5	14.5	J164229 ○	J165652 ○	

● 标准库存品 ● Standard stock item

○ 非标准库存品,直径 < 12mm, 最小起订量是200支; 直径 ≥ 12mm, 最小起订量是100支

○ Non-standard stock item, Diameter < 12 mm minimum order quantity is 200 pcs ; Diameter ≥ 12 minimum order quantity is 100 pcs

**105/4 YELLOW RING
131/3 YELLOW RING**

G20 Copper, G21 hard brass (Ms 58, short chipping), G22 soft brass (Ms 63, long chipping), G23 red brass, G24 phosphor bronze, G25 wrought alloy of aluminium, G29 wrought alloy of magnesium, G34 thermoplastic compounds/synthetics

**105/4 YELLOW RING
131/3 YELLOW RING**

G20 铜, G21 硬黄铜 (Ms 58, 短切削), G22 软黄铜 (Ms 63, 长切削), G23 红铜, G24 磷青铜, G25 锻造铝合金, G29 锻造镁合金, G34 热塑性复合材料/合成纤维

MF

HSSE

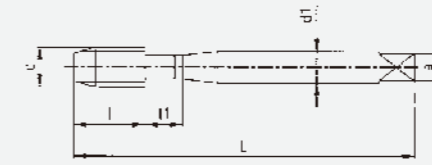

• For stock /有库存

Norm /标准



L	105/4		131/3		d ₁	a	d	P	Art.	Art.
	l	l	l	l						
52	10	7.5	5	4	MF4	0.5	3.5	J866300 ○	J866600 ○	
60	12	7.5	5.5	4.5	MF5	0.5	4.5	J866301 ○	J866601 ○	
62	14	8	6	4.5	MF6	0.75	5.25	J866303 ○	J866604 ○	
70	18	10	6.2	5	MF8	0.75	7.25	J166332 ○	J166633 ○	
70	22	10	6.2	5	MF8	1	7	J166333 ○	J166634 ○	
75	20	12	7	5.5	MF10	0.75	9.25	J166334 ○	J166635 ○	
75	20	12	7	5.5	MF10	1	9	J166335 ○	J166636 ○	
75	24	14	7	5.5	MF10	1.25	8.8	J166336 ○	J166637 ○	
82	22	14	8.5	6.5	MF12	1	11	J166337 ○	J166638 ○	
82	22	14	8.5	6.5	MF12	1.25	10.8	J166338 ○	J166639 ○	
82	22	14	8.5	6.5	MF12	1.5	10.5	J166339 ○	J166640 ○	
88	22	16	10.5	8	MF14	1	13	J166340 ○	J166641 ○	
88	22	20	10.5	8	MF14	1.5	12.5	J166341 ○	J166642 ○	
95	22	16	12.5	10	MF16	1	15	J166342 ○	J166643 ○	
95	22	22	12.5	10	MF16	1.5	14.5	J166343 ○	J166644 ○	

● 标准库存品 ● Standard stock item

○ 非标准库存品,直径 < 12mm, 最小起订量是200支; 直径 ≥ 12mm, 最小起订量是100支

○ Non-standard stock item, Diameter < 12 mm minimum order quantity is 200 pcs ; Diameter ≥ 12 minimum order quantity is 100 pcs

105/4, 131/3 BLACK RING

G01 structural steels < 1000 N/mm², G03 case hardening steels < 1000 N/mm², G08 carbon tool steels, G10 Cr stainless, sulphured, G13 free-cutting steels, G14 cast steels < 1000 N/mm²

105/4, 131/3 BLACK RING

G01 结构钢 < 1000 N/mm², G03 表面硬化钢 < 1000 N/mm², G08 碳素工具钢, G10 Cr 不锈钢, G13 易切钢, G14 铸钢 < 1000 N/mm²

MF

HSSE

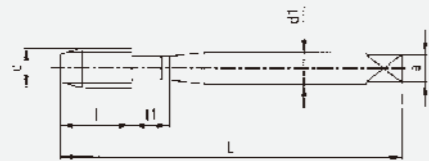

105/3



• For stock /有库存

Norm /标准

T-JIS

ISO 2 (6H)



C/2,5

L	l	d ₁	a	d	P		Art.
70	22	6.2	5	MF8	1		J166712 ◯
75	20	7	5.5	MF10	1		J166713 ◯
82	22	8.5	6.5	MF12	1		J166714 ◯
82	22	8.5	6.5	MF12	1,5		J166715 ◯
88	22	10.5	8	MF14	1,5		J166716 ◯
95	22	12.5	10	MF16	1,5		J166717 ◯

● 标准库存品 ● Standard stock item

○ 非标准库存品, 直径 < 12mm, 最小起订量是200支; 直径 ≥ 12mm, 最小起订量是100支

○ Non-standard stock item, Diameter < 12 mm minimum order quantity is 200 pcs ; Diameter ≥ 12 minimum order quantity is 100 pcs

105/3 GREEN RING

G16 malleable cast iron, G17 nodular graphite cast iron, G18 lamellar graphite cast iron (grey cast iron), G19 vermicular graphite cast iron, G26 aluminium cast alloy Si 0.5% - 5%, G27 aluminium cast alloy Si 5% - 10%, G28 aluminium cast alloy Si > 10%, G30 cast alloy of magnesium, G33 ferro-TiC

105/3 GREEN RING

G16 可锻铸铁, G17 结节性石墨铸铁 (球磨铸铁), G18 片状石墨铸铁 (灰铸铁), G19 蠕墨铸铁, G26 铸造铝合金 Si 0.5% - 5%, G27 铸造铝合金 Si 5% - 10%, G28 铸造铝合金 Si > 10%, G30 铸造镁合金, G33 ferro-TiC 钢结硬质合金

MF

HSSE

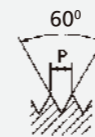
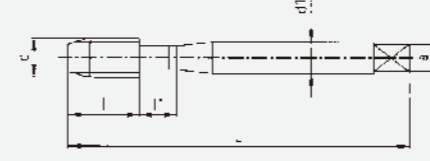

105/4

105/4

131/3

131/3



• For stock /有库存

Norm /标准

T-JIS

T-JIS

T-JIS

T-JIS

ISO 2 (6H)

ISO 2 (6H)

ISO 2 (6H)

ISO 2 (6H)



B/4

B/4

C/2,5

C/2,5

L	105/4		131/3		d ₁	a	d	p		Art.	Art.	Art.	Art.
	l	l ₁	l	l ₁									
52	10	8	7.5	13	5	4	MF4	0.5	3.5	J811870 ◯		J884875 ◯	
60	12	11	7.5	16	5.5	4.5	MF5	0.5	4.5	J811871 ◯		J884883 ◯	
62	14	11	8	18	6	4.5	MF6	0.75	5.25	J811872 ◯		J884891 ◯	
70	18	13	10	21	6.2	5	MF8	0.75	7.25		J111892 ◯		J184789 ◯
70	22	13	10	21	6.2	5	MF8	1	7		J111893 ◯		J184790 ◯
75	20	15	12	22	7	5.5	MF10	0.75	9.25		J111894 ◯		J184791 ◯
75	20	15	12	22	7	5.5	MF10	1	9		J111895 ◯		J184792 ◯
75	24	15	14		7	5.5	MF10	1.25	8.8		J111896 ◯		J184793 ◯
82	22		14		8.5	6.5	MF12	1	11		J811877 ◯		J884956 ◯
82	22		14		8.5	6.5	MF12	1.25	10.8		J811879 ◯		J884964 ◯
82	22		14		8.5	6.5	MF12	1.5	10.5		J811880 ◯		J884972 ◯
88	22		16		10.5	8	MF14	1	13		J811881 ◯		J884980 ◯
88	22		20		10.5	8	MF14	1.5	12.5		J811882 ◯		J884999 ◯
95	22		16		12.5	10	MF16	1	15		J811883 ◯		J885006 ◯
95	22		20		12.5	10	MF16	1.5	14.5		J811884 ◯		J885014 ◯

● 标准库存品 ● Standard stock item

○ 非标准库存品, 直径 < 12mm, 最小起订量是200支; 直径 ≥ 12mm, 最小起订量是100支

○ Non-standard stock item, Diameter < 12 mm minimum order quantity is 200 pcs ; Diameter ≥ 12 minimum order quantity is 100 pcs

105/4, 131/3 BLUE RING

G07 nitriding steels, G09 heat resisting steels, G11 Cr stainless steels, - ferritic and martensitic, G12 Cr-Ni stainless steels, austenitic, G31 alloy of nickel, G32 titanium and alloy of titanium

105/4, 131/3 BLUE RING

G07 氮化钢, G09 耐热钢, G11 Cr 不锈钢, 铁素体不锈钢和马氏体不锈钢, G12 Cr-Ni 不锈钢, 奥氏体不锈钢, G31 镍合金, G32 钛和钛合金

Table of contents of the technical part/技术应用目录

	Page/页
Technical explanations/技术说明	C2
Thread cutting speeds/加工参数	C3~10
Core hole drill sizes/预钻孔尺寸	C11
Thread standard/标准	C12
Tolerance/公差	C13~14
Symbole - chamfer for/图标、导锥形式	C15
Terms - denominations/术语命名	C16
Problems encountered while working with taps/丝锥加工中可能出现的问题	C17~22

Technical Explanations

HSS

HSS is a world wide spread technical term for a tungsten-molybdenum alloyed high-speed steel with a high tenacity and a good cutting ability.

ULTRA or HSSE

Under ULTRA or also called HSSE, we understand a high vanadium- or cobalddalloyed tungsten-molybdenum highspeed steel with an excellent wearing resistance.

AERO

A tap with a special cutting geometry out of highly-alloyed, pression-resisting high speed steel for the manufacturing of NI-based alloys and all high-tensile materials.

GS machine tap

A tap with a special cutting geometry, nitrated, for the manufacturing of cast steel and similar short-chipping materials.

IKZ Machine tap with internal cooling

The big advantage of a tap with internal cooling channel is that the lubrication and cooling fluid can be directly led to the cutting edges in order to enable an even better lubrication.

GG machine tap

A tap with a special cutting geometry, nitrated, for the working of grey cast iron and similar short-chipping materials.

VAP Steam oxydated

In a water steam atmosphere of 530° C we manufacture an oxyde layer which prevents cold welding extensively.

NIT Nitriding

Increase of nitrogene of the tools surface in a tenifer bath at approximately 550° C, 0.02 mm depth.

Hardness = 1100 HV.

Improved friction properties and an increased wearing resistance.

TiN coating (Titanium nitride)

Titanium, evaporated at approximately 500° C.

Hardness = 2200 HV.

Coat thickness = 0.002 mm.

Extremely wear- resp. abraision-resistant.

Very good friction properties.

TiCN coating

Similar procedure to the TiN coating. Titanium-carbon-nitride coating, vapourdeposited in the PVD process at approximately 500° C.

Hardness = 3000 HV.

Coat thickness = 0.002 - 0.003 mm.

In comparison to the TiN coating the tool life is prolonged once more and the cutting speed is increased.

技术说明

HSS

高速钢是一种世界上应用广泛，具有高韧性和良好的切削性能钨钼合金。

ULTRA or HSSE

ULTRA 或者 HSSE (含钒高速钢)，指高钒或钨合金钨钼系高速钢，具有优良的耐磨性能。

AERO

由高合金、耐压高速钢制成，具有特殊的切削几何形状，适合于加工镍基合金和所有的高强度材料。

GS machine tap

具有特殊的切削几何形状，经氮化处理，适合于加工铸钢和类似的短切屑材料。

IKZ Machine tap with internal cooling

具有内冷却孔的优点：冷却液可以直接冷却，润滑切削刃口。

GG machine tap

具有特殊的切削几何形状，经氮化处理，适合于加工灰口铸铁和类似短切屑材料。

VAP Steam oxydated

在约 530°C 的水蒸汽环境中生成氧化物沉积层，可以很大程度地防止粘结。

NIT Nitriding

在约 550°C 的熔融盐浴中进行氮化处理，氮化层厚 0.02mm、硬度 1100 HV，改善了摩擦性能、增加了耐磨性。

TiN coating (Titanium nitride)

真空镀氮化钛，温度 500°C，涂层厚度 0.002mm、硬度 2000HV，TiN 涂层的主要是防止粘结，更好地提高了摩擦性能和耐磨性。

TiCN coating

类似于 TiN 涂层，在约 500°C 通过 PVD 工艺，沉积形成金属钛的碳氮化物涂层，厚度 0.002 ~ 0.003mm、硬度 3000HV。与 TiN 涂层相比，TiCN 涂层允许更高的切削速度，拥有更长的使用寿命。



Chart for taps without coating, steam oxydated and nitrided /无涂层、无氮化及氧化丝锥参数表



Material /材料	Vc mm	Number of revolutions per minute for metrical ISO threads /每分钟转数 (公制ISO螺纹)																															
		1	1.1	1.2	1.4	1.6	1.8	2	2.2	2.5	3	3.5	4	4.5	5	6	8	10	12	14	16	18	20	22	24	27	30	33	36	39	42	45	48
G19 Vermicular graphite cast iron 蠕墨铸铁	12	3820	3472	3183	2728	2387	2122	1910	1736	1528	1273	1091	955	849	764	637	477	382	318	273	239	212	191	174	159	141	127	116	106	98	91	85	80
G20 Copper 铜	10	3183	2894	2653	2274	1989	1768	1592	1447	1273	1061	909	796	707	637	531	398	318	265	227	199	177	159	145	133	118	106	96	88	82	76	71	66
G21 Hard brass (Ms 58, short chipping) 硬黄铜 (Ms58 短切屑)	20	6366	5787	5305	4547	3979	3537	3183	2894	2546	2122	1819	1592	1415	1273	1061	796	637	531	455	398	354	318	289	265	236	212	193	177	163	152	141	133
G22 Soft brass (MS 63, long chipping) 软黄铜 (Ms63, 长切屑)	18	5730	5209	4775	4093	3581	3183	2865	2604	2292	1910	1637	1432	1273	1146	955	716	573	477	409	358	318	286	260	239	212	191	174	159	147	136	127	119
G23 Red brass 红铜	10	3183	2894	2653	2274	1989	1768	1592	1447	1273	1061	909	796	707	637	531	398	318	265	227	199	177	159	145	133	118	106	96	88	82	76	71	66
G24 Phosphor bronze 磷青铜	12	3820	3472	3183	2728	2387	2122	1910	1736	1528	1273	1091	955	849	764	637	477	382	318	273	239	212	191	174	159	141	127	116	106	98	91	85	80
G25 Wrought alloy of aluminium 锻造铝合金	15	4775	4341	3979	3410	2984	2653	2387	2170	1910	1592	1364	1194	1061	955	796	597	477	398	341	298	265	239	217	199	177	159	145	133	122	114	106	99
G26 Aluminium cast alloy Si 0.5% – 5% 铸造铝合金 Si 0.5 – 5 %	20	6366	5787	5305	4547	3979	3537	3183	2894	2546	2122	1819	1592	1415	1273	1061	796	637	531	455	398	354	318	289	265	236	212	193	177	163	152	141	133
G27 Aluminium cast alloy Si 5% – 10% 铸造铝合金 Si 5 – 10 %	20	6366	5787	5305	4547	3979	3537	3183	2894	2546	2122	1819	1592	1415	1273	1061	796	637	531	455	398	354	318	289	265	236	212	193	177	163	152	141	133
G28 Aluminium cast alloy Si >10 % 铸造铝合金 Si >10 %	20	6366	5787	5305	4547	3979	3537	3183	2894	2546	2122	1819	1592	1415	1273	1061	796	637	531	455	398	354	318	289	265	236	212	193	177	163	152	141	133
G29 Wrought alloy of magnesium 锻造镁合金	15	4775	4341	3979	3410	2984	2653	2387	2170	1910	1592	1364	1194	1061	955	796	597	477	398	341	298	265	239	217	199	177	159	145	133	122	114	106	99
G30 Cast alloy of magnesium 铸造镁合金	20	6366	5787	5305	4547	3979	3537	3183	2894	2546	2122	1819	1592	1415	1273	1061	796	637	531	455	398	354	318	289	265	236	212	193	177	163	152	141	133
G31 Alloy of nickel 镍合金	4	1273	1157	1061	909	796	707	637	579	509	424	364	318	283	255	212	159	127	106	91	80	71	64	58	53	47	42	39	35	33	30	28	27
G32 Titanium and alloy of titanium 钛、钛合金	4	1273	1157	1061	909	796	707	637	579	509	424	364	318	283	255	212	159	127	106	91	80	71	64	58	53	47	42	39	35	33	30	28	27
G33 Ferro-Tic 钢结硬质合金	4	1273	1157	1061	909	796	707	637	579	509	424	364	318	283	255	212	159	127	106	91	80	71	64	58	53	47	42	39	35	33	30	28	27
G34 Thermoplastic compounds/synthetics 热塑性复合材料 / 合成纤维	20	6366	5787	5305	4547	3979	3537	3183	2894	2546	2122	1819	1592	1415	1273	1061	796	637	531	455	398	354	318	289	265	236	212	193	177	163	152	141	133
G35 High strength structural steels fine grained 高强度细晶粒结构钢	6	1910	1736	1592	1364	1194	1061	955	868	764	637	546	477	424	382	318	239	191	159	136	119	106	95	87	80	71	64	58	53	49	45	42	40

Chart for taps with hard material coating / 涂层丝锥参数



	Material / 材料	Vc mm	Number of revolutions per minute for metrical ISO threads / 每分钟转数 (公制ISO螺纹)																															
			1	1.1	1.2	1.4	1.6	1.8	2	2.2	2.5	3	3.5	4	4.5	5	6	8	10	12	14	16	18	20	22	24	27	30	33	36	39	42	45	48
G19	Vermicular graphite cast iron 蠕墨铸铁	16	5093	4630	4244	3638	3183	2829	2546	2315	2037	1698	1455	1273	1132	1019	849	637	509	424	364	318	283	255	231	212	189	170	154	141	131	121	113	106
G20	Copper 铜	16	5093	4630	4244	3638	3183	2829	2546	2315	2037	1698	1455	1273	1132	1019	849	637	509	424	364	318	283	255	231	212	189	170	154	141	131	121	113	106
G21	Hard brass (Ms 58, short chipping) 硬黄铜 (Ms58 短切屑)	35	11141	10128	9284	7958	6963	6189	5570	5064	4456	3714	3183	2785	2476	2228	1857	1393	1114	928	796	696	619	557	506	464	413	371	338	309	286	265	248	232
G22	Soft brass (MS 63, long chipping) 软黄铜 (Ms63长切屑)	33	10504	9549	8754	7503	6565	5836	5252	4775	4202	3501	3001	2626	2334	2101	1751	1313	1050	875	750	657	584	525	477	438	389	350	318	292	269	250	233	219
G23	Red brass 红铜	18	5730	5209	4775	4093	3581	3183	2865	2604	2292	1910	1637	1432	1273	1146	955	716	573	477	409	358	318	286	260	239	212	191	174	159	147	136	127	119
G24	Phosphor bronze 磷青铜	21	6685	6077	5570	4775	4178	3714	3342	3038	2674	2228	1910	1671	1485	1337	1114	836	668	557	477	418	371	334	304	279	248	223	203	186	171	159	149	139
G25	Wrought alloy of aluminium 锻造铝合金	24	7639	6945	6366	5457	4775	4244	3820	3472	3056	2546	2183	1910	1698	1528	1273	955	764	637	546	477	424	382	347	318	283	255	231	212	196	182	170	159
G26	Aluminium cast alloy Si 0.5% – 5% 铸造铝合金 Si 0.5 – 5 %	26	8276	7524	6897	5911	5173	4598	4138	3762	3310	2759	2365	2069	1839	1655	1379	1035	828	690	591	517	460	414	376	345	307	276	251	230	212	197	184	172
G27	Aluminium cast alloy Si 5% – 10% 铸造铝合金 Si 5 – 10 %	26	8276	7524	6897	5911	5173	4598	4138	3762	3310	2759	2365	2069	1839	1655	1379	1035	828	690	591	517	460	414	376	345	307	276	251	230	212	197	184	172
G28	Aluminium cast alloy Si >10 % 铸造铝合金 Si >10 %	26	8276	7524	6897	5911	5173	4598	4138	3762	3310	2759	2365	2069	1839	1655	1379	1035	828	690	591	517	460	414	376	345	307	276	251	230	212	197	184	172
G29	Wrought alloy of magnesium 锻造镁合金	24	7639	6945	6366	5457	4775	4244	3820	3472	3056	2546	2183	1910	1698	1528	1273	955	764	637	546	477	424	382	347	318	283	255	231	212	196	182	170	159
G30	Cast alloy of magnesium 铸造镁合金	26	8276	7524	6897	5911	5173	4598	4138	3762	3310	2759	2365	2069	1839	1655	1379	1035	828	690	591	517	460	414	376	345	307	276	251	230	212	197	184	172
G31	Alloy of nickel 镍合金	6	1910	1736	1592	1364	1194	1061	955	868	764	637	546	477	424	382	318	239	191	159	136	119	106	95	87	80	71	64	58	53	49	45	42	40
G32	Titanium and alloy of titanium 钛、钛合金	6	1910	1736	1592	1364	1194	1061	955	868	764	637	546	477	424	382	318	239	191	159	136	119	106	95	87	80	71	64	58	53	49	45	42	40
G33	Ferro-Tic 钢结硬质合金	6	1910	1736	1592	1364	1194	1061	955	868	764	637	546	477	424	382	318	239	191	159	136	119	106	95	87	80	71	64	58	53	49	45	42	40
G34	Thermoplastic compounds/synthetics 热塑性复合材料 / 合成纤维	20	6366	5787	5305	4547	3979	3537	3183	2894	2546	2122	1819	1592	1415	1273	1061	796	637	531	455	398	354	318	289	265	236	212	193	177	163	152	141	133
G35	High strength structural steels fine grained 高强度细晶粒结构钢	10	3183	2894	2653	2274	1989	1768	1592	1447	1273	1061	909	796	707	637	531	398	318	265	227	199	177	159	145	133	118	106	96	88	82	76	71	66



**Core hole drill sizes
螺纹预钻孔尺寸**

ISO 2306 DIN 336	Pitch 螺距	Core/ 底孔		Recommended core/ 建议底孔 drill bit 钻头	Extrem(e) 极值
		Mini 最小	Maxi 最大		
M 33	3,50	29,211	29,771	29,5	29,75
M 36	4	31,670	32,270	32	32,25
M 39	4	34,670	35,270	35	35,25
M 42	4,5	37,129	37,799	37,5	37,75
M 45	4,5	40,129	40,799	40,5	40,75
M 48	5	42,587	43,297	43	43,25

**DIN & T-JIS Metric fine pitch thread
DIN标&T-JIS标公制螺纹（细牙）**

MF 2	0,25	1,729	1,785	1,75	1,75
MF 2,2	0,25	1,929	1,985	1,95	1,95
MF 2,5	0,35	2,121	2,221	2,15	2,20
MF 3	0,35	2,621	2,721	2,65	2,70
MF 3,5	0,35	3,121	3,221	3,15	3,20
MF 4	0,5	3,459	3,599	3,5	3,55
MF 4,5	0,5	3,959	4,099	4	4,05
MF 5	0,5	4,459	4,599	4,5	4,55
MF 6	0,5	5,459	5,599	5,5	5,55
MF 6	0,75	5,188	5,378	5,25	5,35
MF 7	0,75	6,188	6,378	6,25	6,35
MF 8	0,5	7,459	7,599	7,5	7,55
MF 8	0,75	7,188	7,378	7,25	7,35
MF 8	1	6,917	7,153	7	7,15
MF 9	0,75	8,188	8,378	8,25	8,35
MF 9	1	7,917	8,153	8	8,15
MF 10	0,5	9,459	9,599	9,5	9,55
MF 10	0,75	9,188	9,378	9,25	9,35
MF 10	1	8,917	9,153	9	9,15
MF 10	1,25	8,647	8,912	8,8	8,90
MF 11	1	9,917	10,153	10	10,15
MF 12	0,5	11,459	11,599	11,5	11,55
MF 12	0,75	11,188	11,378	11,3	11,35
MF 12	1	10,917	11,153	11	11,15
MF 12	1,25	10,647	10,912	10,8	10,90
MF 12	1,5	10,376	10,676	10,5	10,65
MF 14	1	12,917	13,153	13	13,15
MF 14	1,25	12,647	12,912	12,8	12,90
MF 14	1,5	12,376	12,676	12,5	12,60
MF 15	1	13,917	14,153	14	14,15
MF 15	1,5	13,376	13,676	13,5	13,65
MF 16	1	14,917	15,153	15	15,15
MF 16	1,5	14,376	14,676	14,5	14,65
MF 18	1	16,917	17,153	17	17,15

**DIN & T-JIS Metric pitch thread
DIN标&T-JIS标公制螺纹（粗牙）**

M 1	0,25	0,729	0,785	0,75	0,75
M 1,1	0,25	0,829	0,885	0,85	0,85
M 1,2	0,25	0,929	0,985	0,95	0,95
M 1,4	0,30	1,075	1,142	1,1	1,10
M 1,6	0,35	1,221	1,321	1,25	1,30
M 1,7	0,35	1,256	1,346	1,3	1,30
M 1,8	0,35	1,421	1,521	1,45	1,50
M 2	0,40	1,567	1,679	1,6	1,65
M 2,2	0,45	1,713	1,838	1,75	1,80
M 2,3	0,4	1,795	1,920	1,9	1,90
M 2,5	0,45	2,013	2,138	2,05	2,10
M 2,6	0,45	2,036	2,176	2,1	2,15
M 3	0,50	2,459	2,599	2,5	2,55
M 3,5	0,60	2,850	3,010	2,9	3,0
M 4	0,7	3,242	3,422	3,3	3,40
M 4,5	0,75	3,688	3,878	3,75	3,85
M 5	0,80	4,134	4,334	4,2	4,30
M 6	1	4,917	5,153	5	5,10
M 7	1	5,917	6,153	6	6,10
M 8	1,25	6,647	6,912	6,8	6,90
M 9	1,25	7,647	7,912	7,8	7,90
M 10	1,50	8,376	8,676	8,5	8,60
M 11	1,5	9,376	9,676	9,5	9,60
M 12	1,75	10,106	10,441	10,2	10,40
M 14	2	11,835	12,210	12	12,20
M 16	2	13,835	14,210	14	14,20
M 18	2,50	15,294	15,744	15,5	15,70
M 20	2,50	17,294	17,744	17,5	17,70
M 22	2,5	19,294	19,744	19,5	19,70
M 24	3	20,752	21,252	21	21,20
M 27	3	23,752	24,252	24	24,20
M 30	3,5	26,211	26,771	26,5	26,75

Thread standard \ 螺纹标准

DIN M	ISO metric coarse thread DIN 13/DIN ISO 965 ISO公制粗螺纹DIN13/ DIN ISO 965	DIN MF	ISO metric fine thread DIN 13/DIN ISO 965 ISO公制细螺纹DIN13/ DIN ISO 965
-------	---	--------	---

**Conversion of the designation
for taps with metrical ISO thread**

The issue of the DIN EN 22 857 replaces the DIN 802, part 1 which has been withdrawn.

The European standard indicates the tolerance of manufacturing for the thread part of taps, which is for producing metrical ISO threads with tolerance 4H up to 8H and 4G up to 6G.

The essential change of the DIN EN 22 857 compared with the DIN 802, part 1, is the conversion of the designation for taps as per application classes. They were adapted to the international standard. The following table shows you the connection of DIN EN 22 857 with the withdrawn DIN 802, part 1, for the tolerance field with different applications of the taps.

DIN EN 22857		Tolerance field of the internal screw thread					DIN 802, part 1 (withdrawn)
Application class of the taps							Tolerance class of the taps
Class 1	ISO 1	4H	5H				4H
Class 2	ISO 2	4G	5G	6H			6H
Class 3	ISO 3			6G	7H	8H	6G
—	—				7G	8H	7G

With the catalogue 1997 we took over the designation of the taps according to the DIN EN 22857, but during the transition period we will add also the tolerance classes of taps as per withdrawn DIN 802, part 1. This will guarantee the faultless assign of the tap in the application.

Example:

M 10 for tolerance field of the internal screw thread 6H
as per DIN 22857 M 10 ISO 2
as per DIN 802, part 1 (withdrawn) M 10 – 6H

For the further designation the DIN 2197 ist still valid and is applied unchanged. During the transition period the taps will be delivered with new as also old designation.

Example:

M 12 x 1,5-ISO 2 (6H)

The tolerance class which are not registered in the DIN EN 22857 as for example 7G, 8G and the X-tolerances remain unchanged as per withdrawn DIN 802, part 1. Concerning this, a new standard is in preparation.

Example:

The designation of a internal screw thread M 10 with additional oversize for tolerance 6H: M 10-6HX

丝锥应用与ISO公制螺纹转换

DIN EN 22857 代替 DIN802 已撤销的第 1 部分。

欧洲标准指出丝锥螺纹部分的制造公差，这是用于制造公差 4h 到 8h 和 4G 到 6G 的公制 ISO 螺纹。

相比 DIN802 第 1 部分，DIN EN 22857 有实质性的改变，是指丝锥类别应用中的转换。这个新标准符合国际标准。

下表显示了 DIN EN22857 与撤销的 DIN802 第 1 部分的相互关系，对于丝锥不同应用的公差范围。

DIN EN 22857		内螺纹的公差范围					DIN 802 第1部分 (已撤销)
丝锥的应用等级							丝锥的公差等级
Class 1	ISO 1	4H	5H				4H
Class 2	ISO 2	4G	5G	6H			6H
Class 3	ISO 3			6G	7H	8H	6G
-	-				7G	8H	7G

1997 年样本中，我们的丝锥依据 DIN EN 22 857 设计，但过渡期间我们也依据 DIN 802 第 1 部分增加丝锥的公差等级，这将保证应用的完整性。

例如：M 10 的内螺纹公差范围——6H

根据 DIN 22 857

根据 DIN 802 第 1 部分 M 10——ISO 2

M 10——6H

DIN 2197 IST 的应用不变，在过渡期间丝锥的新、老应用型号共存。

例如：M 12 × 1.5——ISO 2 (6H)

公差等级不执行 DIN EN 22857 的，例如 7G、8G 和“X”保持不变，仍按照撤销的 DIN 802，第 1 部分执行。关于这一点，一个新的标准正在制订中。

例如：一个 M 10 中径加大的 6H 内螺纹设计：

M 10——6HX

Symbols /图标

DUO duo colour ring tap / 双色环丝锥

p pitch in mm / 螺距(mm)



core hole drill / 钻头

柄部形状/SHANKS LENGTH T-JIS 公制螺纹 T-JIS Metric thread

柄径 d1	3	4	5	5.5	6	6.1	6.2	7	8	8.5	9	9.5	10	10.5	11	12	12.5	13	
四方部长 lk	5	6	7	8	9	10	11	12	13										
四方部宽 a	2.5	3.2	4	4.5	5	5.5	6	6.5	7	8	9	10							

Chamfer form /导锥形式

Form(e) B

Chamfer form for taps as per DIN. The length of the chamfer is between 3,5 and 5 threads.

丝锥的导锥形式，符合 DIN 标准，倒角长度在 3.5 到 5 倍螺距。

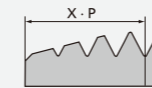

Form(e) C

Chamfer form for taps as per DIN. The length of the chamfer is between 2 and 3 threads.

丝锥的导锥形式，符合 DIN 标准，倒角长度在 2 到 3 倍螺距。

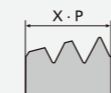

Form(e) E

Chamfer form for taps as per DIN. The length of the chamfer is between 1,5 and 2 threads.

丝锥的导锥形式，符合 DIN 标准，倒角长度在 1.5 到 2 倍螺距。



Problem	Causes	Solutions
Widening in a curve	<p>Wrong choice of tap (geometry not adapted) Angle or position error Countersink is missing</p> <p>The cutting force is too high (feed)</p> <p>The cutting force is too low (feed)</p> <p>Tap has been reground</p> <p>Machine spindle and compensation chuck do not function axially</p>	<p>Select a suitable tap as per application chart Correct alignment of tap and drilled hole Provide the core hole, before cutting the thread, with a countersink 90°</p> <p>With a manual feed reduce the pressure, use a compensation chuck/tap holder. Verify the adjusted feed on the machine, possibly reduce the feed (only possible with a compensation chuck)</p> <p>Verify the adjusted feed on the machine. With manual feed increase the pressure</p> <p>Tap has the wrong geometry or a burred edge. Regrind the tool again, eventually choose a new tap</p> <p>Check the function of the spindle and the compensation chuck, if possible use a smaller machine</p>
Rough thread surface	<p>Wrong choice of tap (geometry not adapted) Dull tap Tap is damaged or has cold welding</p> <p>Insufficient lubrication Chip packing in tap flutes Cutting speed too high or too low</p> <p>Core drill too small</p> <p>Tap has been reground</p>	<p>Select a suitable tap as per application chart Use a new tap Use a new tap, evaluate coolant being used, possibly use a tap with surface treatment</p> <p>Improve the lubrication, if possible use cutting oil Avoid chip packing in the flutes or under the work piece</p> <p>Choose the correct speed as per chart, please also consider the working material</p> <p>Choose the core hole as per chart, for hard materials aim for the upper tolerance limit</p> <p>Tap has the wrong geometry or a burred edge. Regrind the tool again, possibly choose a new tap.</p>
Tool life too short	<p>Wrong choice of tap (geometry not adapted) Cutting speed too high or too low</p> <p>The working material is abrasive (grey cast iron, aluminium/cast alloy with Si, plastic with glass fibres reinforced etc.) Insufficient lubrication Work-hardened surface of the core hole, due to blunt or not suitable drills</p>	<p>Select a suitable tap as per application chart Choose the correct speed as per chart, please also consider the working material</p> <p>Use a tap with surface treatment</p> <p>Improve the lubrication, if possible use cutting oil Use sharp and suitable drills. For hard materials avoid the use of carbide drills</p>

Problem	Causes	Solutions
Tap breakage	<p>Wrong choice of tap (geometry not adapted) Taps bottoming in the hole</p> <p>Angle or position error Countersink is missing</p> <p>Core hole drill too small</p> <p>Dull tap Working piece thin walled and/or material with high expansion</p> <p>Chip packing in tap flutes Tap has been reground</p>	<p>Select a suitable tap as per application chart Verify the adjustment of the thread length, consider the chamfer length and possibly the centre point. Avoid the use of a safety clutch on a machine with forced feed Correct alignment of tap and drilled hole Provide the core hole, before cutting the thread, with a countersink 90° Choose the core hole as per chart, for hard materials aim for the upper tolerance limit Use a new tap During the return the tap is gripped by the work piece. Use a tap with a higher relief. If possible use a special execution Avoid chip packing in the flutes or under the working piece Use a new tap</p>
Breakage of chamfer and/or guiding teeth	<p>Wrong choice of tap (geometry not adapted) Chip packing in tap flutes</p> <p>Core hole drill too small</p> <p>Dull tap Taps bottoming in the hole</p> <p>Angle or positional error</p> <p>Material too hard</p>	<p>Select a suitable tap as per application chart Avoid chip packing in the flutes or under the working piece. Blind holes being tapped in a recessed hole can cause the breakage of individual teeth on the upper part of the tap Choose the core hole as per chart, for hard materials aim for the upper tolerance limit Use a new tap Verify the adjustment of the thread length, consider the chamfer length and possibly the centre point. Avoid the use of a safety clutch on a machine with forced feed Choose the core hole as per chart, for hard materials aim for the upper tolerance limit Use a tap with more flutes, or use a set of taps</p>

丝锥加工中可能出现的问题

问题	原因	对策
中径扩大	<p>丝锥选择不当 角度或位置误差 螺纹底孔没加工倒角 螺纹底孔太小 丝锥损坏或有粘结 切削速度过高或过低</p> <p>切屑堵塞 选用的丝锥公差等级错误 丝锥重磨不当</p>	<p>依据应用图表选择合适的丝锥 丝锥和底孔正确对齐 攻丝前底孔孔口应该加工有90° 倒角 依据图表选择底孔，硬材料选择公差上限 换新的丝锥，使用冷却液，使用带涂层丝锥 依据被加工材料、图表选择合适的切削速度 检查机床主轴或夹具的轴向补偿功能，尽量选用较小的机床</p> <p>确保排屑通畅 使用的量具和丝锥要在一个公差等级 重磨丝锥，确保丝锥有适合被加工材料的几何角度，重磨后刃口无毛刺，更换新丝锥</p>
中径缩小	<p>工件薄壁或材料具有高膨胀性 丝锥选择错误（几何形状不适合） 选用的丝锥公差等级错误 轴向螺距误差</p>	<p>选用高公差等级、中径加大的丝锥 依据应用图表选择合适的丝锥 使用的量具和丝锥要在同一公差等级 请参阅<轴向螺距误差></p>
轴向螺距误差	<p>丝锥选择错误（几何形状不适合） 螺纹底孔没加工倒角 切削力太高（进给）</p>	<p>依据应用图表选择合适的丝锥 攻丝前底孔孔口应该加工有90° 倒角 使用补偿夹具/攻丝架手动进给减少压力，调整降低机床进给（仅带补偿夹具）</p>

问题	原因	对策
	<p>切削力太低（进给） 主轴和进给不同步</p>	<p>调整机床进给，手动进给增加压力 机床的调整是不正确的，使用补偿夹具，确认机床的相关设置</p>
喇叭形入口	<p>丝锥选择错误（几何形状不适合） 角度或位置误差 螺纹底孔没加工倒角</p> <p>切削力太高（进给）</p> <p>切削力太低（进给）</p> <p>丝锥重磨不当</p> <p>机床主轴或夹具的轴向补偿不起作用</p>	<p>依据应用图表选择合适的丝锥 丝锥和底孔正确对齐 攻丝前底孔孔口应该有90° 倒角</p> <p>使用补偿夹具/攻丝架手动进给减少压力，调整降低机床进给（仅带补偿夹具）</p> <p>调整机床进给，手动进给增加压力</p> <p>重磨丝锥，确保丝锥有适合被加工材料的几何角度，重磨后刃口无毛刺，更换新丝锥 检查机床主轴或夹具的轴向补偿功能，尽量选用较小的机床</p>
螺纹表面粗糙度不良	<p>丝锥选择错误（几何形状不适合） 丝锥磨损、钝 丝锥损坏或有粘结 润滑不足</p> <p>切屑堵塞 切削速度过高或过低</p> <p>螺纹底孔太小 丝锥重磨不当</p>	<p>依据应用图表选择合适的丝锥更换丝锥 更换丝锥，使用冷却液，使用带涂层丝锥 提高润滑，可以使用切削油 确保排屑通畅</p> <p>依据被加工材料、图表选择合适的切削速度 依据图表选择底孔，硬材料选择公差上限</p> <p>重磨丝锥，确保丝锥有适合被加工材料的几何角度，重磨后刃口无毛刺，更换丝锥</p>
丝锥寿命太短	<p>丝锥选择错误（几何形状不适合） 切削速度过高或过低 被加工材料的原因（灰铸铁，含Si的铝/铸铝合金，玻璃纤维增强塑料，等）</p> <p>润滑不足 由于钻头磨损或不适合钻孔，从而导致底孔的表面硬化</p>	<p>依据应用图表选择合适的丝锥 依据被加工材料、图表选择合适的切削速度 选用涂层丝锥</p> <p>提高润滑，可以使用切削油 选用锋利和适当的钻头，对于硬材料避免使用硬质合金钻头</p>

问题	原因	对策
丝锥破损	丝锥选择错误（几何形状不适合） 丝锥攻底 角度或位置误差 螺纹底孔没加工倒角 螺纹底孔太小 丝锥磨损、钝 工件薄壁或材料具有高膨胀性 切屑堵塞 丝锥重磨不当	依据应用图表选择合适的丝锥 确认螺纹长度，考虑导锥长度和可能的中心点， 避免在机床上使用刚性攻丝 丝锥和底孔正确对齐 攻丝前底孔孔口应该加工有90° 倒角 依据图表选择底孔，硬材料选择公差上限更换新丝锥 选用高公差等级、中径加大的丝锥 确保排屑通畅 更换新丝锥
导锥破损	丝锥选择错误（几何形状不适合） 切屑堵塞 螺纹底孔太小 丝锥磨损、钝 丝锥攻底 角度或位置误差 材料太硬	依据应用图表选择合适的丝锥 确保排屑通畅，盲孔内有上一序切屑残留，容 易造成切削锥破损 依据图表选择底孔，硬材料选择公差上限 更换新丝锥 确认螺纹长度，考虑导锥长度和可能的中心点， 避免在机床上使用刚性攻丝 丝锥和底孔正确对齐 选用更多排屑槽的丝锥，或选用一套丝锥

Metalcutting Safety

IMPORTANT SAFETY INSTRUCTIONS Read before using the tools in this catalogue! Projectile and Fragmentation Hazards:

Modern metalcutting operation involve high spindle and cutter speeds and high temperatures and cutting forces. Although hot metal chips and temperatures, they can sometimes fragment, particularly if they are subjected to over-stress, severe impact, or other abuse.

To avoid injury:

- Always wear appropriate personal protective equipment, including safety goggles, when operating metalcutting machines or working nearby.
- Always make sure all machine guards are in place.

Breathing and Skin Contact Hazards:

Grinding carbide or other advanced cutting tool materials produces dust or mist containing metallic particles. Breathing this dust or mist—especially over an extended period—can cause temporary or permanent lung disease or make existing medical conditions worse. Contact with this dust or mist can irritate eyes, skin, and mucous membranes and may make existing skin conditions worse.

To avoid injury:

- Always wear breathing protection and safety goggles when grinding.
- Provide ventilation control and collect and properly dispose of dust, or sludge from grinding.
- Avoid skin contact with dust or mist.

For more information, read the applicable Material Safety Data Sheet provided by Cleveland and consult General Industry Safety and Health Regulations.

These safety instructions are general guidelines. Many variables affect machining operations. It is impossible to cover every specific situation. The technical information included in this catalogue and recommendations on machining practices may not apply to your particular operation.

金属切削安全

重要安全说明： 使用该目录中刀具之前请阅读！ 抛射物及碎屑的危险

现代金属切削主轴和刀片运转速度快，温度高和切削力大。高温金属切削会在切削中从工件飞离。虽然设计和生产的切削刀具可以承受很大的切削力和高温，有时也会产生碎片，尤其是在受到过大压力，严重冲击，或其它使用不当的情况下。

避免受伤：

- 在操作金属切削机床或在附近工作时，一定要戴好个人防护设备，包括防护眼镜。
- 一定确保安装好机器的防护装置。

呼吸与皮肤接触危险：

研磨硬质合金或其它高级切削刀具材料时会产生带金属颗粒的粉尘或雾。吸入这样的粉尘或雾——尤其是长期吸入，会引起暂时或永久性的肺部疾病，或者会使现在的身体状况更糟。接触这样的粉尘或雾会刺激眼睛，皮肤和粘膜，使现在的皮肤状况更糟。

避免受伤：

- 在研磨时，一定要佩戴呼吸保护装置和防护眼镜。
- 要通风，控制，收集并合理处理研磨产生的粉尘、雾或渣滓。
- 避免皮肤接触粉尘或雾。