

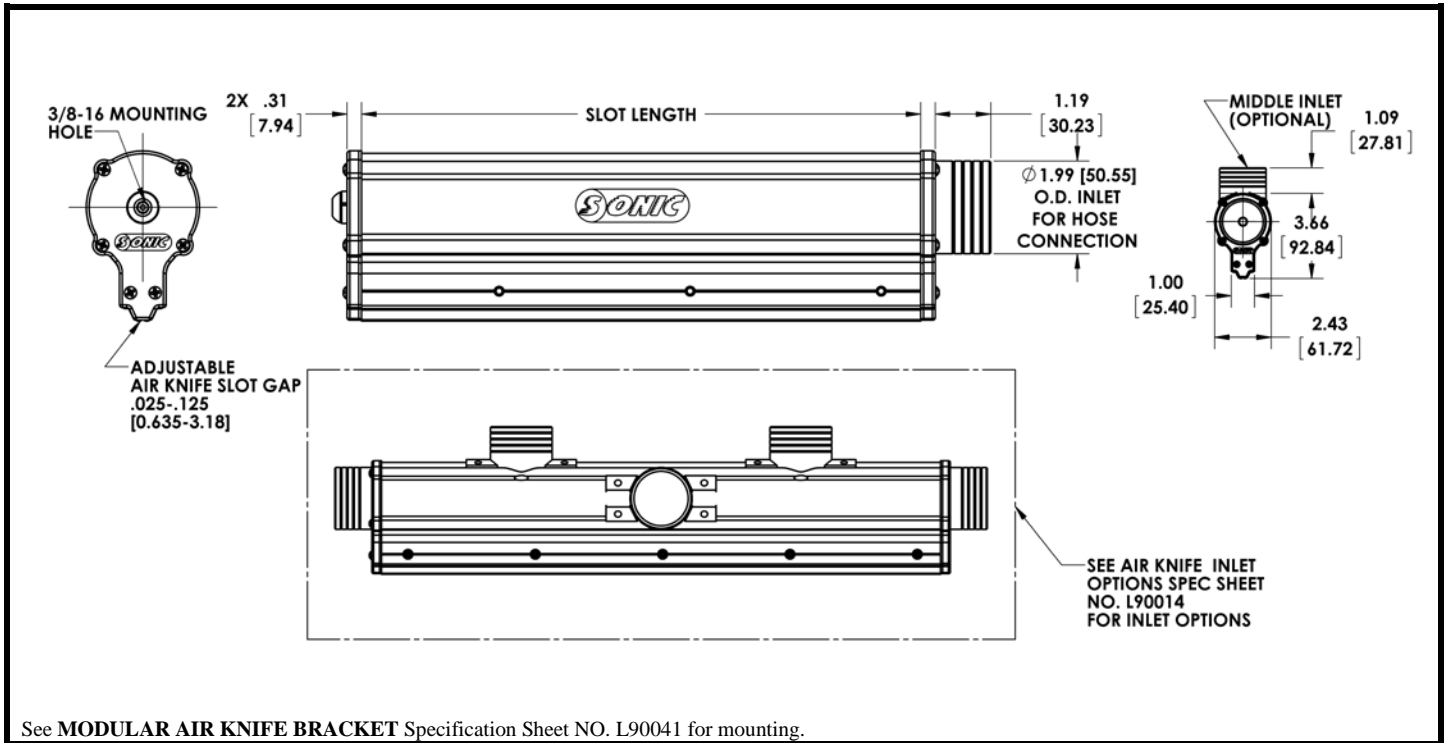

Product Specification Sheet

AIR KNIFE - 2" XE
HARD ANODIZED ALUMINUM

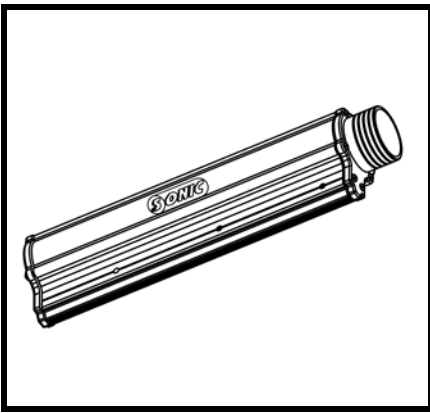

See MODULAR AIR KNIFE BRACKET Specification Sheet NO. L90041 for mounting.

Dimensions in Inches, [] are in millimeters

Description	Air Knife-2" XE %%" LG
Sonic Part Number	CALL SONIC
Standard Slot Length	2.00 to 36.00in [50.8 to 914.0mm]
Custom Slot Length	37.00 to 72.00in [939.8 to 1,828.8mm]
Air Flow Rate	3.5 cfm/in to 16.9 cfm/in (65.0 lps/m to 314.0 lps/m)
Maximum Air Discharge Velocity	38,000 fpm (11,582 mpm)
Temperature Range	-40°F to 275°F (-40°C to 135°C)
Material	Body – 6063 Aluminum Extrusion End/Inlet Cap – Aluminum Hardware- 300 Series S.S.
Finish	Hard Anodized, Type III
Weight (Approx.)	2.00 lbs/ft (2.98 g/mm)



Product Specification Sheet

AIR KNIFE - 3" XE
HARD ANODIZED ALUMINUM

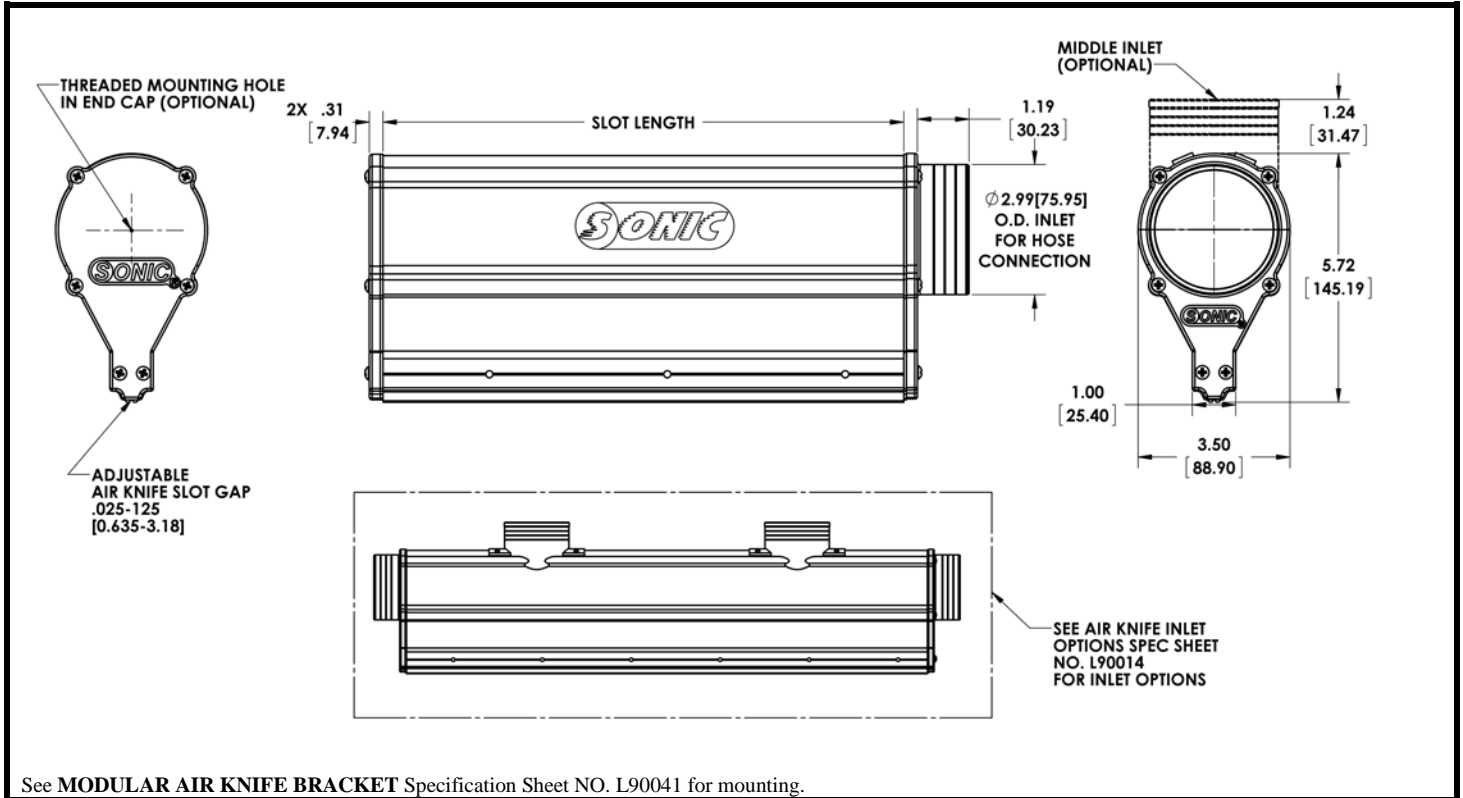
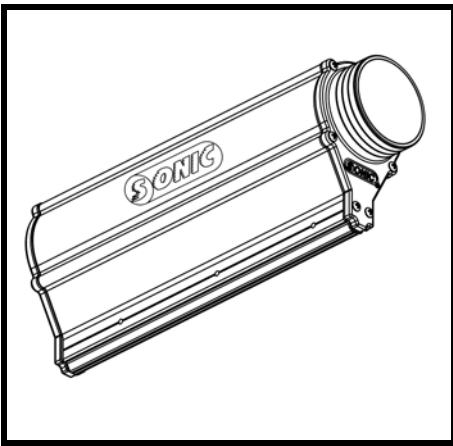

See MODULAR AIR KNIFE BRACKET Specification Sheet NO. L90041 for mounting.

Dimensions in Inches [] are in millimeters

Description	Air Knife-3" XE %% " LG
Sonic Part Number	CALL SONIC
Standard Slot Length	2.00 to 144.00in [50.8 to 3658.0 mm]
Custom Slot Length	145.0 to 196.0in [3,683 to 4,880mm]
Air Flow Rate	3.5 cfm/in to 16.9 cfm/in (65.0 lps/m to 314.0 lps/m)
Maximum Air Discharge Velocity	38,000 fpm (11,582 mpm)
Temperature Range	-40°F to 275°F (-40°C to 135°C)
Material	Body – 6063 Aluminum Extrusion End Cap/Inlet Cap - Glass Filled Nylon Hardware-300 Series S.S.
Finish	Hard Anodized, Type III
Weight (Approx.)	2.96 lbs/ft (4.40 g/mm)