

Republic offers a complete line of centrifugal blowers for vacuum or compressed air applications. Centrifugal blowers provide dry, clean, oil-free air and require low energy consumption. Unlike compressed air systems, this series is safe to run at low pressure, and allows for increased production speeds or levels.

The RB800 is robust and hard-working. The blower comes with ceramic hybrid bearings, 360 degree rotatable outlet discharge, easy to remove stainless steel bearing housing assembly, and zinc plated steel motor pulley.



PERFORMANCE

Vacuum Pressure

60Hz

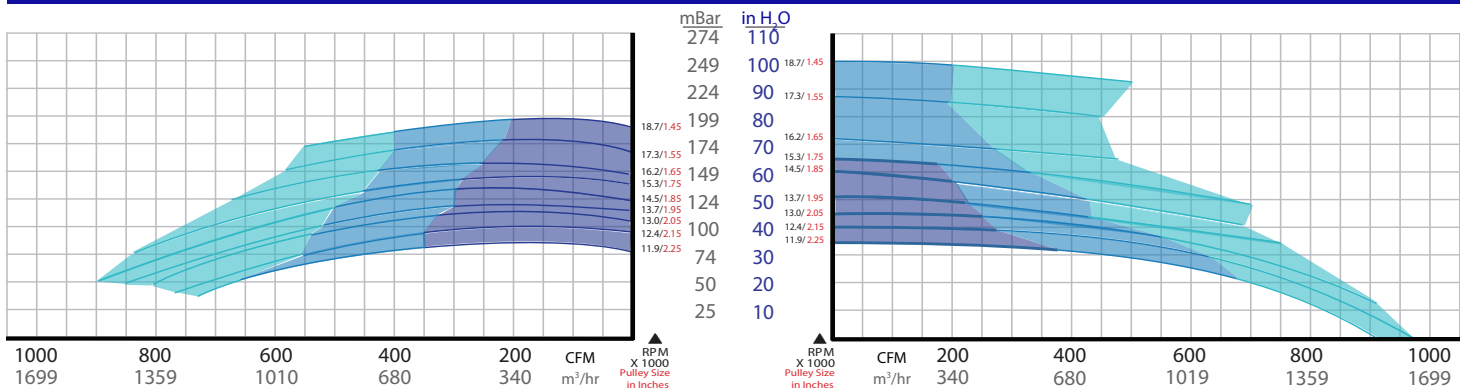

50Hz

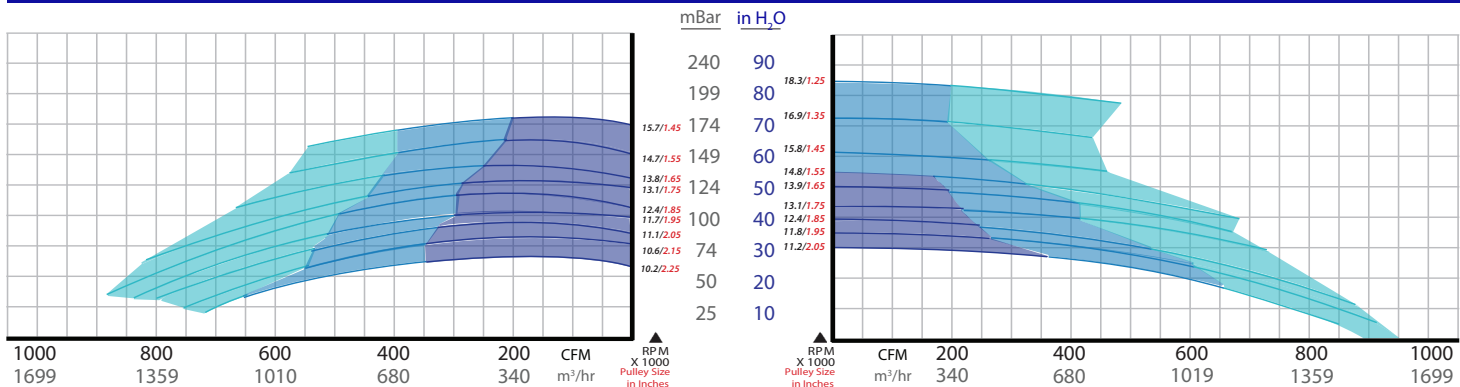

Standard cubic feet per minute, air at 14.7 PSIA, 68°F, 36% R.H.
 $1''\text{H}_2\text{O}=0.074''\text{Hg}=0.036\text{PSIG}=0.57\text{oz}=25.4\text{mm H}_2\text{O}$

■ 5HP ■ 7.5HP ■ 10HP

Model	Frequency (Hz)	HP	Max Flow (CFM/m³/hr)	Max Vacuum (in. H ₂ O/mbar)	Max Pressure (in. H ₂ O/mbar)	Sound Level (db) with Enclosure/without Enclosure	Weight (lb/kg)	Retro Kit Weight (lb/kg)
RB800	50	5 (184TC)	375/637	73/182	55/134	82/96	149/67	69/32
	60		375/637	78/194	65/162			
	50	7.5 (213TC)	675/1,147	73/182	85/212	82/96		
	60		675/1,147	77/192	100/249			
	50	10 (215TC)	950/1,614	69/172	84/209	82/96	226/102	
	60		975/1,657	75/189	99/247			

APPROXIMATE DIMENSIONS

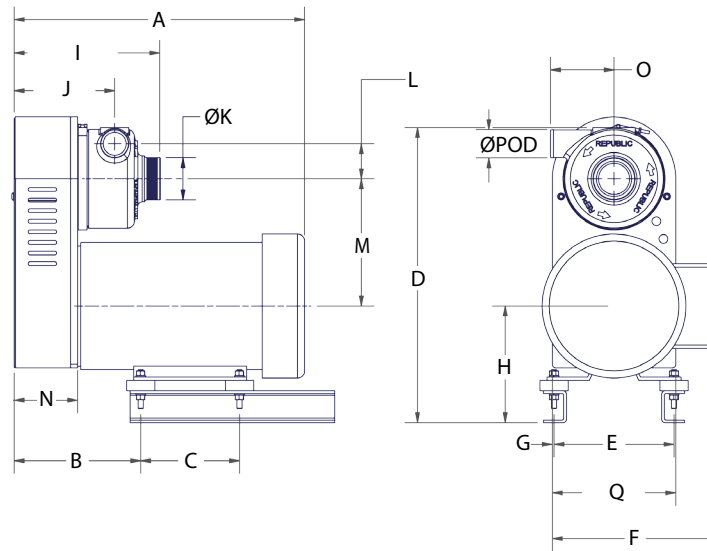

HP	Unit	A	B	C	D	E	F	G	H	I	J	K	L	M	N	O	P	Q
5 (184TC)	in	18.00	7.00	5.50	23.00	7.50	11.00	1.00	7.50	12.00	8.00	10.00	Ø 3.98	4.50	4.00	6.50	3.00	10.00
	mm	433	206	114	587	191	302	32	191	308	206	101	Ø 92	260	114	165	76	254
7.5 (213TC)	in	20.50	8.00	5.50	23.00	8.50	12.00	0.75	8.00	12.00	8.00	10.00	Ø 3.98	4.50	4.00	6.50	3.00	10.00
	mm	508	229	140	587	216	331	19	210	308	206	101	Ø 92	260	114	165	76	254
10 (215TC)	in	20.50	8.00	7.00	23.00	8.50	12.00	0.75	8.00	12.00	8.00	10.00	Ø 3.98	4.50	4.00	6.50	3.00	10.00
	mm	517	229	178	587	216	332	19	210	308	206	101	Ø 92	260	114	165	76	254

Available Options

Republic Centrifugal Blowers are made to order, and can be customized to fit almost any application. Many common options and accessories are listed below. For additional options, please contact Republic or your local distributor.

Advantages

- 5-10 Horsepower – up to 18,700 rpm
- 16 Groove belt for long life
- Lightweight & Small footprint
- Ceramic hybrid bearings
- Multi-lip seals on both ends of the shaft
- Blower outlet discharge is rotatable
- Precision balanced shaft/impeller assemblies
- Stainless steel blower pulley, zinc plated steel motor pulley, aluminum blower housing
- 6061 T6 aluminum impeller
- Bearing housing is steel construction for extra rigidity
- Operational with all types of motors– washdown, explosion proof, high efficiency and hydraulic
- Easy to remove bearing/impeller housing for quick repair
- 100% Operational performance and vibration tested
- One year warranty

Options

- Hard anodized bearing housing assembly
- Inlet and outlet flanges
- Water-cooled blower

Accessories

- Enclosures for noise control
- Exhaust silencer
- Starter panel
- Variable frequency drive